

Concrete Batching Plant

Background

Concrete Batching Plants (CBP) were originally located within construction sites for supply of concrete for on-site construction activities. Such CBP were commonly considered to be machinery and equipment and did not in the circumstances fall into the definition of 'building' under the Buildings Ordinance (BO). Over time, some CBP have evolved to become bigger, and others sited in urban areas, near buildings and public thoroughfares.

2. From time to time, Authorized Persons (AP) and Registered Structural Engineers (RSE) exercise their professional judgment in determining whether to submit plans of CBPs to the Building Authority (BA) for approval. Buildings Department (BD) also advises, in response to specific enquiries, on the need for submission of plans for approval.

Building Works

3. What constitutes a building and therefore becomes subject to the application of the BO is a question of degree and circumstances, including any risk they may pose to public safety. The BA is of the view that CBP fixed to and founded on the ground, connected to a utility supply and with a control room, are buildings under the BO. Hence approval and consent are required prior to their erection.

Requirements

4. Taking into account the growing concern on the public safety posed by contemporary CBP¹, the BA takes the following position on CBP: -

New CBP

- (a) For new CBP including associated structures such as cement, sand and aggregate handling facilities, building plans prepared by AP and RSE should be submitted to the BA for approval in accordance with the BO and regulations (including compliance with the town plan) before they are erected. For the common type of CBP shown on Appendix A, BA is prepared to process applications for approval and consent simultaneously upon request and such applications will be dealt with as outlined in Appendix B;

/(b)

¹ Contemporary CBP may comprise, inter alia, washing-out pits, elevators, conveyor belts, ground hoppers, mixing drums, workspaces and offices, silos, water-tanks, storage areas/tanks, structural supports including foundations

- (b) An occupation permit or a temporary occupation permit shall be applied for, depending on the requirements of the operator or nature of the site, upon satisfactory completion of works in accordance with the provisions of the BO and regulations; and
- (c) Enforcement action under the BO in accordance with the prevailing policy for the control of unauthorized building works will be taken against new CBP and associated structures erected after 31 March 2002 without prior approval and consent.

Existing CBP

- (d) Action against existing CBP erected prior to 1 May 2002 will not be taken if their structural safety can be demonstrated through submission of satisfactory appraisal reports by a RSE by 30 October 2002 and such plant is properly maintained. This notwithstanding, other government departments may still initiate enforcement actions against individual CBP which fails to comply with the relevant provisions under applicable Ordinances, or respective land use requirements.

5. In the longer term, we will explore the feasibility of setting up a statutory system for self-certification of CBP with a total silo capacity less than 50 tonnes and having an overall height less than 15 m.

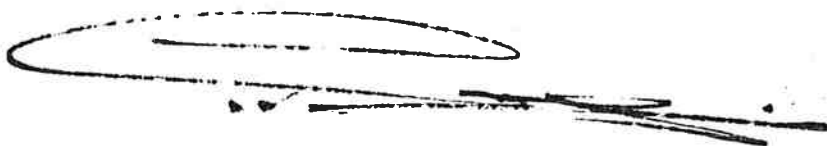

(C M Leung)
Building Authority

Ref.: GP/BORD/73 (II)

First Issue March 2002 (AD/NB1, AD/NB2)

Index under: Concrete Batching Plant

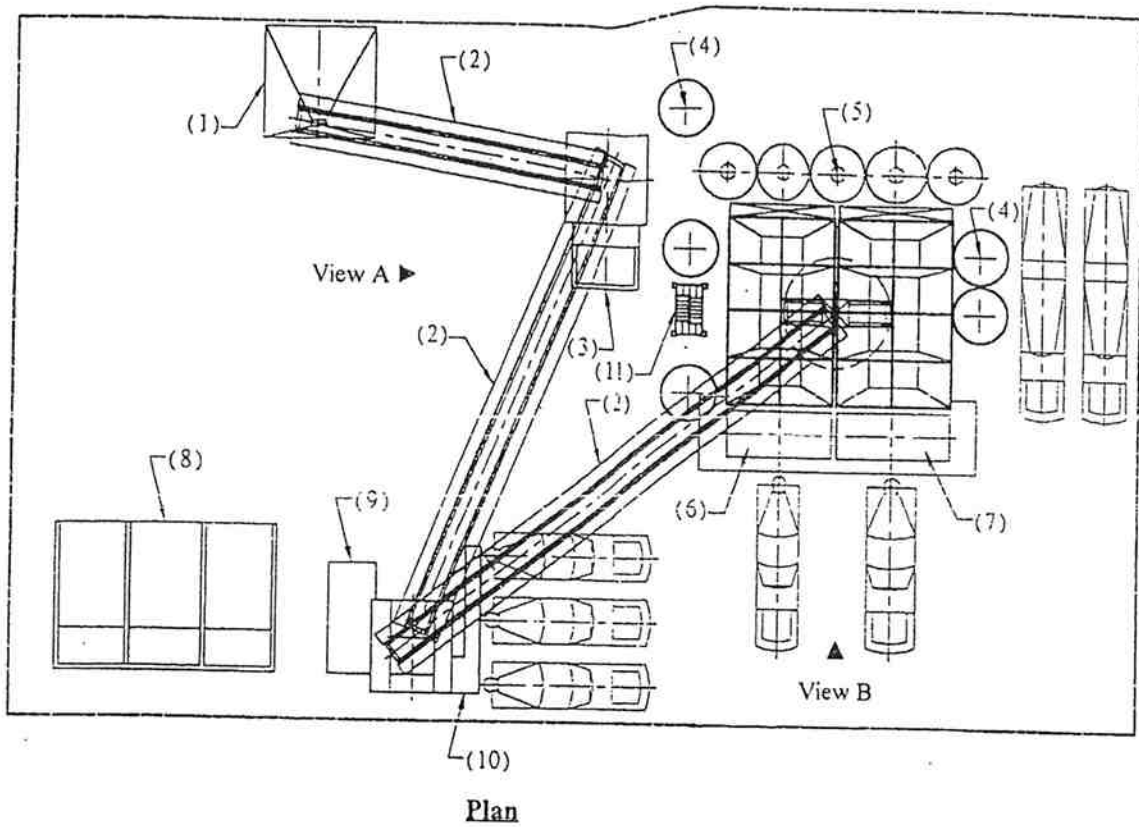

LEGEND

- (1) UNDERGROUND CHAMBER FOR BARGE
- (2) CONVEYOR BELT
- (3) ICE-CUBE TANK
- (4) WATER TANK
- (5) CEMENT SILO
- (6) CONTROL ROOM
- (7) CONTROL ROOM
- (8) WASTE MATERIALS CHAMBER & WASTE WATER CHAMBER
- (9) STORAGE ROOM
- (10) TESTING PLATFORM
- (11) STAIRCASE

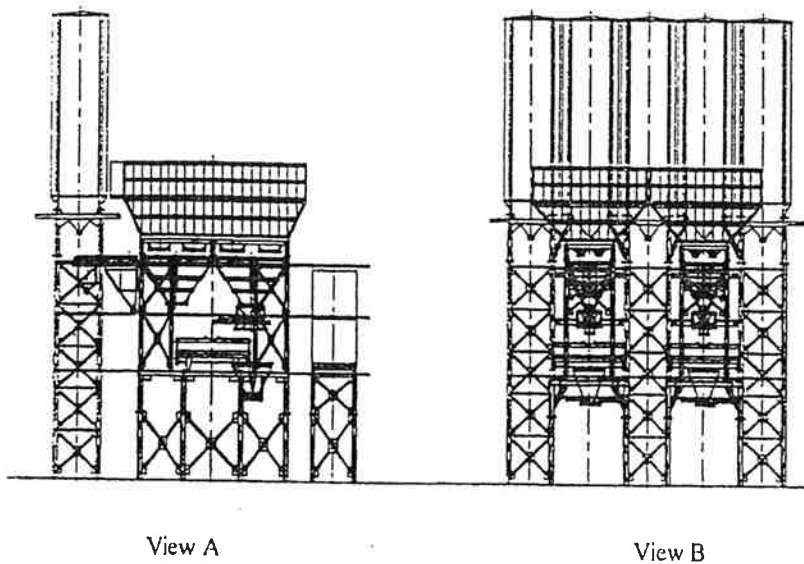

Elevations

(Some parts of the plant are omitted for the sake of clarity)

A typical 2-production line concrete batching plant

In respect of those type of CBP's as shown in Appendix A (the number of production lines may vary) the following arrangements under the BO will be accepted: -

New CBP

- Requirements for Fire Resisting Construction (FRC) will be waived provided no part of the CBP is within 1800mm of the site boundary other than a sea wall and the gross floor area (GFA) of the control room does not exceed 30m² per production line. Water storage tanks and settlement pits will normally be allowed up to the site boundary without FRC requirements.
- Means of escape (MOE) requirements will be waived provided that the GFA of the control room does not exceed 30m² per production line and the number of personnel in it does not exceed 5 per production line. The clear width of any staircase access to the control room should be not less than 750mm clear with a handrail each side and with a going not exceeding 45°. Requirements under Building (Planning) Regulation 72 in respect of the identified control room will be waived if the above criteria are met.
- The above waiver on FRC, MOE and Building (Planning) Regulation 72 requirements are subject to the following conditions -
 - (i) the number of production lines does not exceed 4 and
 - (ii) the total GFA of all control rooms does not exceed 100 m².
- If drainage connections or discharges off-site are made any requirements of Drainage Services Department and Environmental Protection Department must be met. Drainage details may be included on the general building plan submission.
- Plot ratio and site coverage calculations may exclude conveyor belts, but not their supporting structures. Plot ratio calculations based on the site coverage area may be accepted subject to extra office floors and the like at other levels being included.

Rearrangement of layout of CBP

- Submissions in respect of minor alteration to the plant layout, after issue of an Occupation Permit or Temporary Occupation Permit involving a conveyor belt support and associated hopper, will be processed within 30 days.

/Relocation

Relocation of an approved CBP

- Relocation of an approved CBP to a new site will be subject to a new 60-day submission, however the original structural calculations may be used subject to reassessment for wind load and ground conditions by a RSE. The structural submission will be processed within 30 days provided the site is similar in all respects to the existing site and satisfies all the requirements as stipulated in Appendix C.
- The general building plan submission will also be processed within 30 days provided referral to other departments (except FSD) is not required. (Practice Note for Authorised Persons and Registered Structural Engineer No 99 is relevant.)

Existing unapproved CBPs

- In respect of existing unapproved CBP's the structural justification required for its stability and integrity will be restricted to basic details of the main structural components and by at least one trial pit in respect of the existing foundations together with an appraisal and inspection report on the existing conditions of all the structural elements and member connections and certification by a RSE for their fitness for use.

Relocation of existing unapproved CBP

- Relocation of an existing unapproved CBP to a new site will be dealt with as a new 60-day submission. In respect of the above ground structural elements justification should be by way of laboratory tests etc together with an appraisal and inspection report on the existing conditions of all the structural elements and certification by a RSE for their fitness for re-use.

Non Typical CBP

- If the plant contains features or accommodation which are not in a typical batching plant, or cannot meet the waiver requirements, the proposal for the whole plant will be processed in the same manner as for an ordinary building.

(3/2002)

Requirements for 30-day processing of structural submissions in respect of 'Relocation of an approved CBP'

(A) Superstructure

RSE is to certify the following during the plan submission :-

- (i) the structural framing plans, members and connection details are the **same** as the approved plans dated _____ under the reference of BD _____.
- (ii) the structural calculations, including the method of analysis, wind load, dead load, live load and material design stresses and the relevant standards submitted for the approved plans mentioned above have been reviewed and found to be equally applicable to the new CBP now proposed.

(B) Foundations

RSE is to certify the following during the plan submission :-

- (i) the foundation plans showing the foundation system, allowable bearing pressure, type, layout and details are the **same** as the approved plans dated _____ under the reference of BD _____.
- (ii) the structural calculations for the foundation details including the method of analysis, loadings and material design stresses and the relevant standards submitted for the approved plan mentioned above have been reviewed in conjunction with the site investigation report for the CBP now proposed, and are found to be equally applicable to the new CBP now proposed.

(C) Referrals of Superstructure and Foundation Plans

The RSE is to certify that the new CBP proposal does not involve or affect the followings and hence referral to each of the organisation is **not** required.

Does proposal involve or affect the following?	Referral to each of the relevant organisation
Schedule Area No. 1, 2 or 4	Geotechnical Engineering Office
Schedule Area No. 3 or MTR Protection Area	Mass Transit Railway Corporation

/Schedule

Schedule Area No. 5	(a) Geotechnical Engineering Office; and (b) Drainage Services Department
Slopes/Retaining Structures/Deep excavation/disused tunnel	Geotechnical Engineering Office
Culvert, nullah, stream course	Drainage Services Department or Project Manager, Territory Development Department for New Territory area
Kowloon Canton Railway route protection area or proposed rail routes	Railway Division, Highways Department
Light Rail Transit	Light Rail Division, Kowloon Canton Railway Corporation
Structures to be erected in, over, under or upon street	(a) Lands Department; and (b) Highways Department
Highway Structures	Highways Department
Sea walls, adjacent to sea front	Technical Services Division, Civil Engineering Department
Reclamation, piers	(a) Marine Department; and (b) Technical Services Division, Civil Engineering Department
Public drainage	Drainage Services Department
Water mains	Water Supplies Department

(3/2002)