

## Design and Construction of Cantilevered Reinforced Concrete Structures

The structural stability of cantilevered reinforced concrete structures in particular those of pure slab type relies on their proper design, construction and maintenance. Furthermore, the fact that weathering may lead to the early degradation of material strength should be borne in mind when carrying out the design and construction of cantilevered members exposed to weathering<sup>[1]</sup>. Common examples of this type of structural elements are projecting structures located on the exteriors of buildings like canopies, balconies, projecting windows, A/C hoods, A/C platforms, flowerbeds etc. Their collapse would have serious consequences.

2. This Practice Note gives guidance to Authorized Persons (AP) and Registered Structural Engineers (RSE) on the safe design and construction of cantilevered reinforced concrete structures. Appendix A gives guidance notes on structural design, construction, drainage provision, site supervision and maintenance for achieving the necessary safety standards. Appendix B provides recommendation for the construction of construction joint for exposed cantilevered slabs. For projects involving the erection of cantilevered reinforced concrete structures, the means to prevent the accumulation of water and the corresponding surface water drainage provisions for such structures should be shown on the general building plans and drainage plans respectively for approval. The above plans submissions conforming to the recommendations of paragraph 4 of Appendix A will be considered as complying with Regulations 4(b) and 10(3) of the Building (Planning) Regulations (B(P)R). Structural submissions conforming to the recommendations in Appendix A will be considered as complying with the performance requirements set out in Regulation 4 of the Building (Construction) Regulations. The requirements on supervision, standards of workmanship and submission of construction reports will be the Building Authority's conditions for approval of plans and consent to commence works.



( AU Choi-kai )  
Building Authority

Ref. : BD GP/BORD/23 (III)

This PNAP is previously known as PNAP 173

First issue October 1994

Last revision November 2005

This revision September 2012 (AD/NB2 & AD/NB1) – Paras. 1 & 2 and Appendices A & B revised and Appendix C deleted

<sup>[1]</sup> For the purpose of this practice note, cantilevered structures under permanent solid cover located at not greater than one storey height and of at least the same plan area as such solid cover may be considered as not exposed to weathering.

## Guidance Notes on Design and Construction of Cantilevered Reinforced Concrete Structures

### General Requirements

1. The design of cantilevered structures should satisfy the following requirements:-
  - (a) For cantilever of clear span more than 1000 mm, a beam-and-slab type of arrangement should be used instead of pure slab cantilever where practicable.
  - (b) The span to effective depth ratio of cantilevered beams or slabs should comply with clause 7.3.4.2 of the Code of Practice for Structural Use of Concrete 2004 (Second Edition) (the Concrete Code).
  - (c) Dead loads due to finishes, parapets and waterproofing materials, and imposed loads due to maintenance work and possible ponding resulting from malfunctioning of the drainage system should be accurately assessed and allowed for in the design.
  - (d) Cantilevered structures, especially those projecting over streets, should be detailed in such a manner that they may be demolished or replaced without affecting the safety and integrity of the main structure of the building.
  - (e) The extent of projection from the external wall and the clear space above the level of the ground of cantilevered structures should comply with Regulations 7 and 10 of the B(P)R and PNAP APP-19 as appropriate.
2. The construction of cantilevered structures should satisfy the following requirements:-
  - (a) All cantilevered structures should be cast monolithically with and at the same time as the directly supporting members. Construction joints should **not** be located along the external edge of the supporting members. In case this is unavoidable, any alternative construction method must be submitted for prior approval. Such method should ensure that the finished product would be able to attain a structural strength no less than that provided by monolithic construction, and that it would not allow the ingress of water through the joint.
  - (b) Adequate bar spacers should be provided to maintain the position and alignment of the steel reinforcing bars.
  - (c) Placing and compacting of concrete should comply with clause 10.3.5 of the Concrete Code. Every endeavour should also be made to avoid steel reinforcing bars from being displaced or depressed.



- (d) Removal of formwork and falsework should comply with clause 10.3.8.2 of the Concrete Code.
3. The AP/RSE/Registered General Building Contractor (RGBC) should provide the appropriate level of supervision and inspection on the construction of cantilevered structures so as to ensure compliance with the approved plans. Supervision requirements shall be in accordance with Table 9.1 of the Code of Practice for Site Supervision 2009.
4. Means to prevent accumulation of water should be provided to cantilevered structures exposed to weathering<sup>[1]</sup> and shown on the general building plans whereas the corresponding surface water drainage provisions should be shown on the drainage plans for approval. In this connection the following are to be observed:-
- (a) Effective waterproofing should be provided.
- (b) Water-proof membrane/tanking should be protected by 1:3 cement sand mortar laid to a fall of not less than 1:75. Wherever practicable, adequate drainage should be provided to drain the surface water away from the cantilevered structure. If for any reason, the design is to guide the water to just cascade down from the edge of the cantilevered structure, e.g. in the case of projecting windows, the AP/RSE should ensure that by so doing it will not create any nuisance to anyone in accordance with Regulation 4(b) of the B(P)R. A continuous drip or groove should always be provided at the bottom edge of the cantilevered structure to keep the dripping water away. All canopies, irrespective of whether projecting over streets or not, should be provided with adequate surface water drainage to discharge into the surface water disposal system of the building.
- (c) Where the cantilevered structure is not accessible for cleaning/maintenance, the maximum distance between the drainage outlets, if provided, should be not more than 5 m.
- (d) Every endeavour should be made to avoid penetration or embedment of pipes in cantilevered structures, especially slab elements. If unavoidable, consideration must be given to any local reduction in structural strength affected by the surface drainage system or embedded service pipes and ducts. In this regard, AP/RSE are reminded to make reference to PNAP APP-105 on the requirements and guidelines of embedment of water-borne pipes inside reinforced concrete beams and slabs.

---

<sup>[1]</sup> For the purpose of this practice note, cantilevered structures under permanent solid cover located at not greater than one storey height and of at least the same plan area as such solid cover may be considered as not exposed to weathering.

## **Cantilevered Beams**

5. The structural design of cantilevered beams should satisfy the following requirements:-
- (a) The overall depth at support should be at least 300mm.
  - (b) Top and bottom steel reinforcing bars should be securely held in position by stirrups with the top bars anchored in accordance with clause 9.4.3 of the Concrete Code, and any top bar extended to resist support moments in the adjacent span should also comply with the curtailment rules specified in the Concrete Code. Where support by cross beam cannot be avoided, the supporting beam and the adjacent internal slabs should be adequately designed and properly detailed for any internal moment, torsion, shear and axial force so induced.
  - (c) External cantilevered beams should be designed for exposure condition 2 or higher if appropriate in accordance with the Concrete Code.

## **Cantilevered Slabs**

6. The structural design of cantilevered slabs should satisfy the following requirements:-
- (a) The minimum overall thickness should be--
    - (i) 110 mm for span not greater than 500 mm;
    - (ii) 125 mm for span greater than 500 mm but not greater than 750 mm;
    - (iii) 150 mm for span greater than 750 mm.
  - (b) Any wall supporting the cantilever slab, except that for very small span slabs like air-conditioner hoods, should be of sufficient thickness to provide the necessary rigidity and to allow the proper anchorage of the main steel reinforcing bars of the cantilevered slabs. This is in addition to any other design consideration that is required for the wall itself.
  - (c) Cantilevered slabs should be reinforced with high yield steel bars in both faces and in both directions. Main steel reinforcing bars should be at least 10mm diameter and spacing should not be greater than 150 mm, and the steel area should not be less than 0.25% of the cross-sectional area of the structural concrete.
  - (d) The main steel reinforcing bars of cantilevered slabs should be anchored in accordance with clause 9.4.3 of the Concrete Code, and any top bar extended to resist support moments in the adjacent span should also comply with the curtailment rules specified in the Concrete Code. For cantilevered slabs with drop at the supporting end, top main steel reinforcing bars of not greater than 16 mm in diameter should be used in



order that an effective and proper anchorage into the supporting beams and internal slab can be developed. Details of steel reinforcing bars should be drawn in a sufficiently large scale to indicate clearly the connections.

- (e) Consideration and specific details should be provided for--
  - (i) cantilevered slabs continuing around corners of buildings due to increase in slab area and a change in direction of the main steel reinforcing bars;
  - (ii) the side edge of cantilevered slabs where there is an additional load from return parapets running parallel to the cantilever span direction.
  
- 7. The requirements set out in paragraph 6 above do not apply to in-fill slabs enclosed by edge beams, or slabs supported in such a way that they do not behave similar to cantilevered slabs.
  
- 8. External cantilevered slabs should satisfy the following requirements:-
  - (a) The maximum crack width at the tension face should be limited to 0.1 mm when carrying out design check under the serviceability limit state or the stress of deformed high yield steel reinforcing bars used should not exceed 100 N/mm<sup>2</sup> when checking the flexural tension under the working load condition.
  - (b) Concrete cover to steel reinforcing bars should be designed for exposure condition 2 or higher if appropriate in accordance with the Concrete Code.
  
- 9. External cantilevered slabs with a span exceeding 750 mm exposed to weathering<sup>[1]</sup> should satisfy the following additional requirements:-
  - (a) The AP/RSE, in conjunction with the RGBC where appropriate, is required to submit a construction report upon completion of the works. A Form BA 14 confirming that the works have been carried out in accordance with the approved plans and are structurally safe should also be submitted;
  - (b) Concrete should be water-proof concrete of characteristic compressive strength not less than 35MPa at 28 days;
  - (c) All main steel reinforcing bars should be hot-dip galvanized to BS EN ISO 1461; and
  - (d) Water-proof membrane/tanking should be provided and protected by 1:3 cement sand mortar of 0.65 maximum free water/cement ratio or other equivalent means.

10. The construction report required under paragraph 9(a) above should include the following: -
- (a) an as-built plan showing --
    - (i) the location and dimensions of the members of the cantilevered slab;
    - (ii) the direction and gradient of the fall, where applicable;
    - (iii) the location of the drainage outlets, where applicable;
    - (iv) the thickness of screeding and finishes;
    - (v) the details of the water-proof membrane/tanking, where applicable;
    - (vi) the location and details of any construction joints;
    - (vii) the grade of concrete and steel reinforcing bars;
    - (viii) the diameter and spacing of steel reinforcing bars in the cantilevered slab;
    - (ix) the date on which the concrete was cast; and
    - (x) the concrete cover of the steel reinforcing bars at critical positions, as measured by covermeter.
  - (b) record photographs of the cantilevered slab and its supporting members showing --
    - (i) the condition and arrangement of the in-position steel reinforcing bars prior to concreting; and
    - (ii) the condition after concreting but before laying of the finishes and waterproofing materials.

### **Maintenance and Repair**

11. The structural integrity of cantilevered slab canopy may be impaired rapidly should the prevailing adverse conditions persist such as improper use as air-conditioner support, lack of maintenance and repair, and mal-functioning of drainage facilities.
12. Upon the completion of the construction of a cantilevered slab canopy, the AP should coordinate with the RSE and RGBC to prepare documentation on the inspection and maintenance of the cantilevered slab canopy, for regular maintenance and repair to be arranged by the Incorporated Owners/management company. Routine inspection and maintenance works such as cleaning of clogged drain pipes and drainage channel, and inspection of waterproofing system and finishes should be carried out regularly and particularly during the rainy seasons.

(Rev. 09/2012)

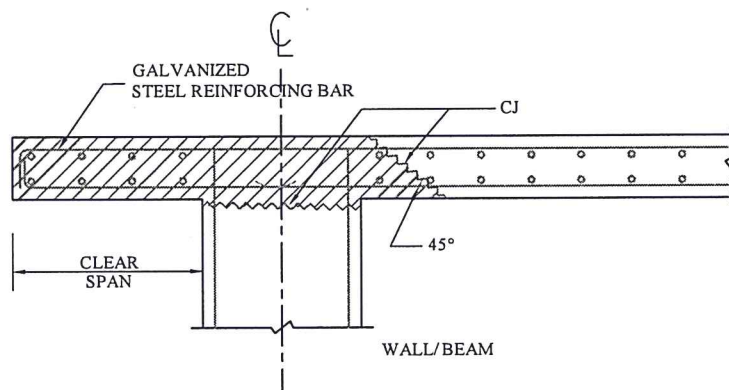

(i) CONTINUOUS SLAB

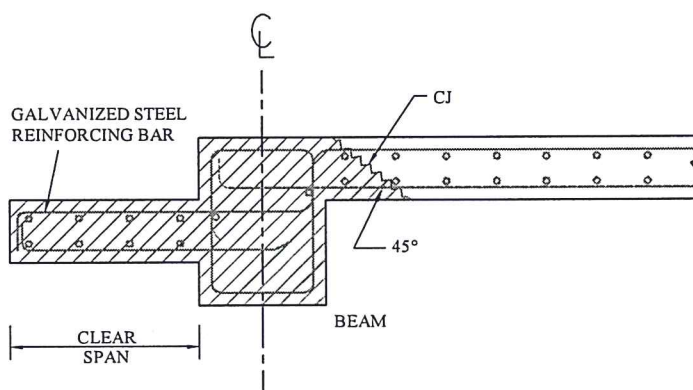

(ii) DROP SLAB

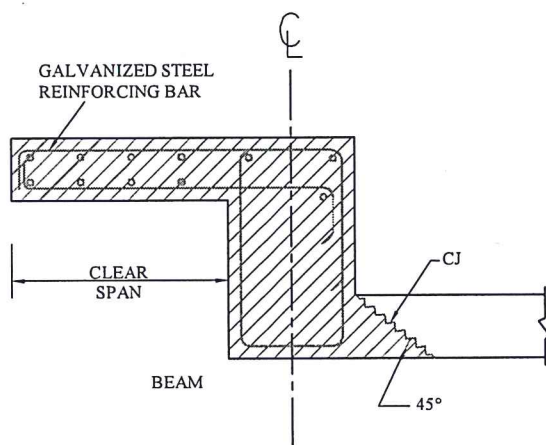

(iii) SLAB SUPPORTED AT BEAM TOP

LEGEND:  
CJ - CONSTRUCTION JOINT  
WATER-PROOF CONCRETE

RECOMMENDED LOCATION OF CONSTRUCTION  
JOINT FOR EXPOSED CANTILEVERED SLAB