

Amendments to the Design Manual: Barrier Free Access 2008
(September 2015)

Legends:

 Amended

 Deleted

Item	2008 version	Amendments
1. Paragraph 5.5 B(a)(vi) in Chapter 5 ¹	lift buttons should comply with paragraphs 80(1) and (4) in Division 19;	lift buttons and emergency call button should comply with paragraphs 80(1) to 80(8) and 80(i) and 80(ii) in Division 19;
2. Paragraph 5.5 B(a)(viii) in Chapter 5	grab bars complying with paragraphs 28(3) and (4) in Division 8 should be placed at a height of 900mm from the finished floor level and be fixed on both sides and at the rear of the lift car;	grab bars complying with paragraphs 28(3) and (4) in Division 8 should be placed at a height of 900mm from the finished floor level and be fixed on both sides and at the rear of the lift car (lift door(s) excepted);
3. Paragraph 5.5 B(a)(ix) in Chapter 5 ²	the maximum travel should be 4000mm;	the maximum travel should be 7000mm;
4. Paragraph 5.5 B(a)(xii) in Chapter 5 ³	The landings to a vertical lifting platforms at the 2 access levels should be in opposite directions so as to eliminate the need for the wheelchair to back-out.	Every landing to a vertical lifting platform should be in opposite direction or located at 90° relative to all other landings so as to eliminate the need for the wheelchair to back-out. This requirement does not apply to a vertical lifting platform which is provided with power-operated and automatically controlled horizontally sliding or swing doors. The kinetic energy of the automatic doors should not exceed 10J.

¹ To unify the standards of control buttons and emergency call button of a vertical lifting platform as an accessible lift.

² To extend the limit of travel height of a vertical lifting platform to 7000mm taking into account current Code of Practice on the Design and Construction of Lifts and Escalators issued by the Electrical and Mechanical Services Department.

³ To control the arrangement on access to and egress from a vertical lifting platform with a maximum travel height up to 7000mm which may serve more than two access levels. Back-out arrangement of the wheelchair is allowed if a vertical lifting platform provided with automatic doors similar to an accessible lift with automatic doors.

Item

2008 version

Amendments

5. Figure 45

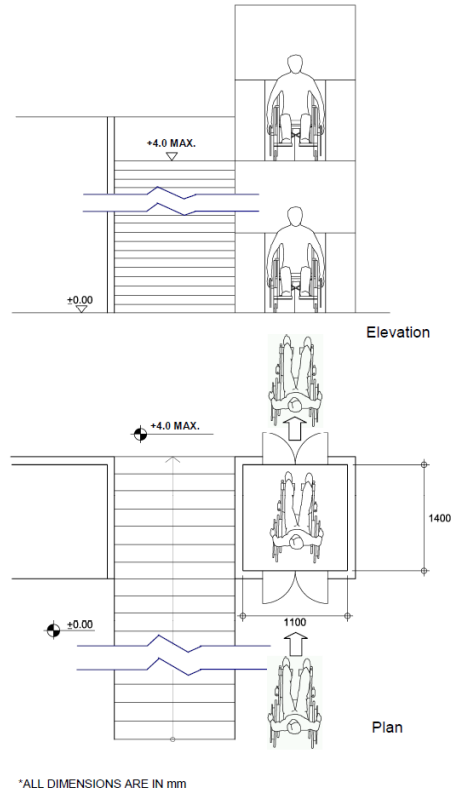

Figure 45 – Vertical Lifting Platform

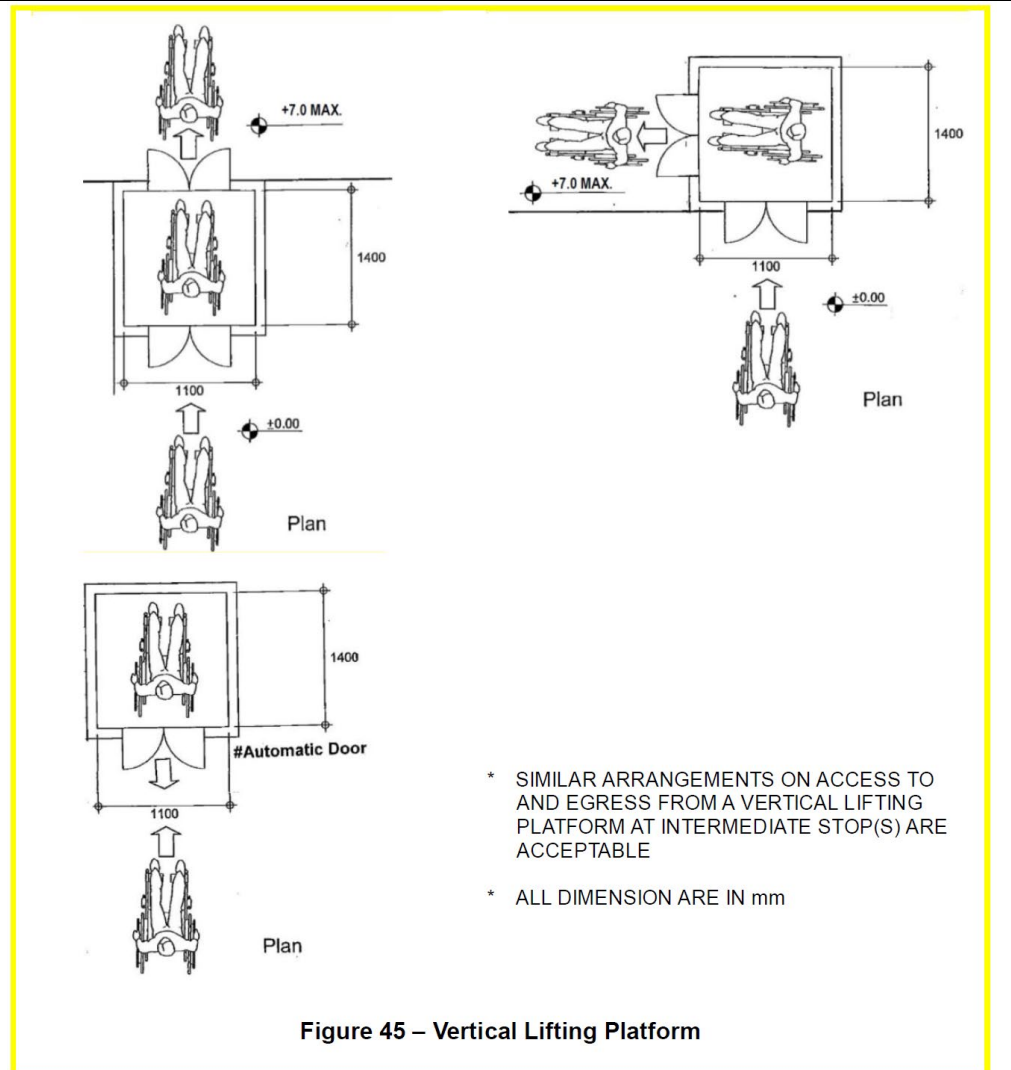

Figure 45 – Vertical Lifting Platform

* SIMILAR ARRANGEMENTS ON ACCESS TO AND EGRESS FROM A VERTICAL LIFTING PLATFORM AT INTERMEDIATE STOP(S) ARE ACCEPTABLE

* ALL DIMENSION ARE IN mm