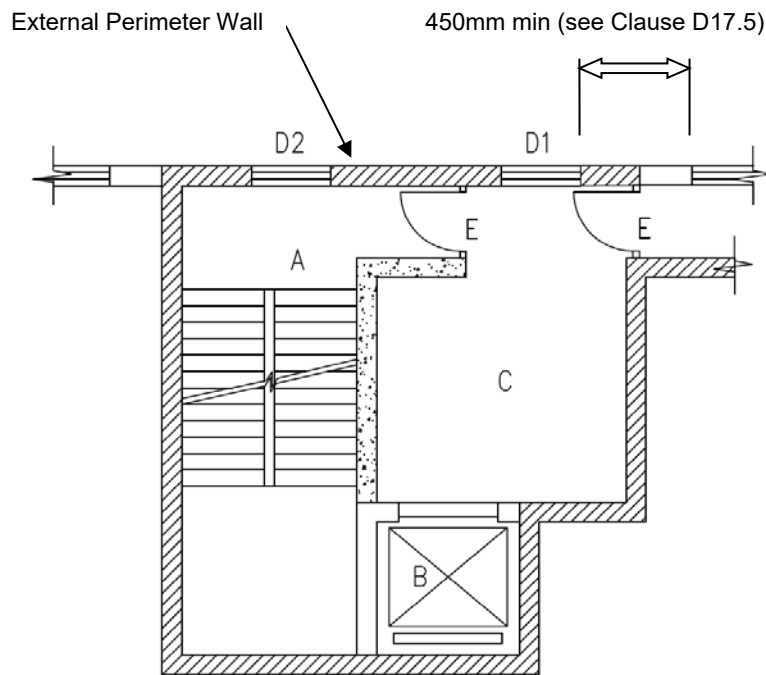

Diagram D1: Requirements of a Firefighting and Rescue Stairway above Ground Storey



Perimeter enclosure walls with FRR required in Clause D17.2



Lobby walls with FRR required in Clause D17.3

- A Access Staircase - min. width 1.05m (see Clause D18.1 (a))
- B Fireman's Lift - min. car size 1.35m² and rated load 680kg (see Clause D10.1)
- C Ventilated Lobby - size 5m² - 10m² and min. dimension 1.5m (see Clause D16.1(a))
- D1 Lobby Openings - min. size 25% of lobby floor area (see Clause D16.1(c))
- D2 Staircase windows - min. size 15% of staircase area (see Clause D19.1(b))
- E Lobby Doors - self-closing, complying with Part C (see Clause D17.4)

Note:

1. Ventilation may be omitted where a suitable mechanical system, such as pressurization, is provided to the satisfaction of the Director of Fire Services (see Clause D21.1)

Diagram D2: Ventilation of Lobby of Firefighting and Rescue Stairway
Below Ground Storey

Alternative 1 (smoke outlets)

Smoke outlets at ceiling - - min. size 1m² per lobby and lobbies to be individually ventilated (see Clause D16.1(d)(i))

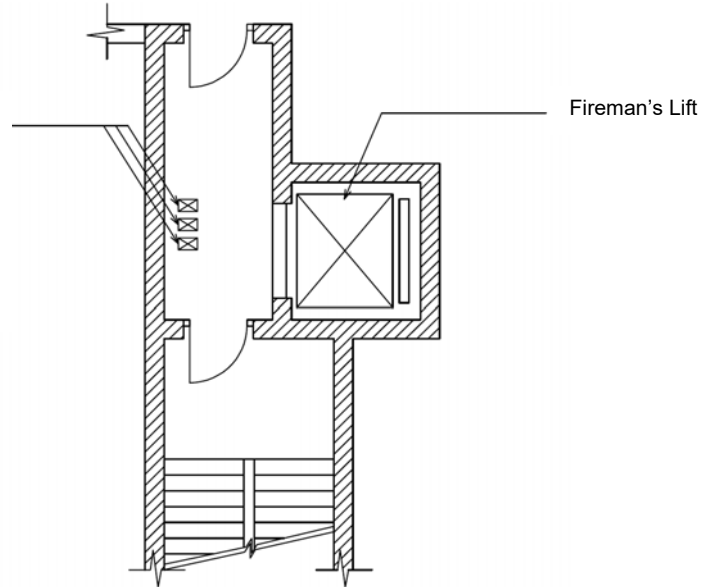

Alternative 2 (open well)

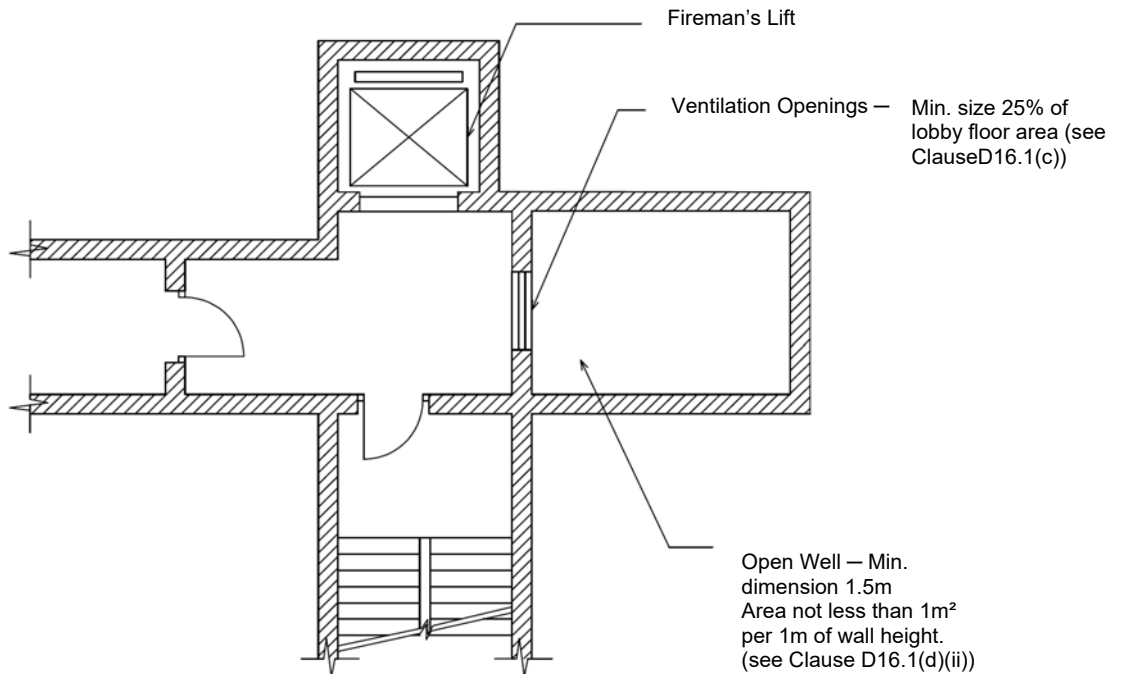

Alternative 3 (open staircase)

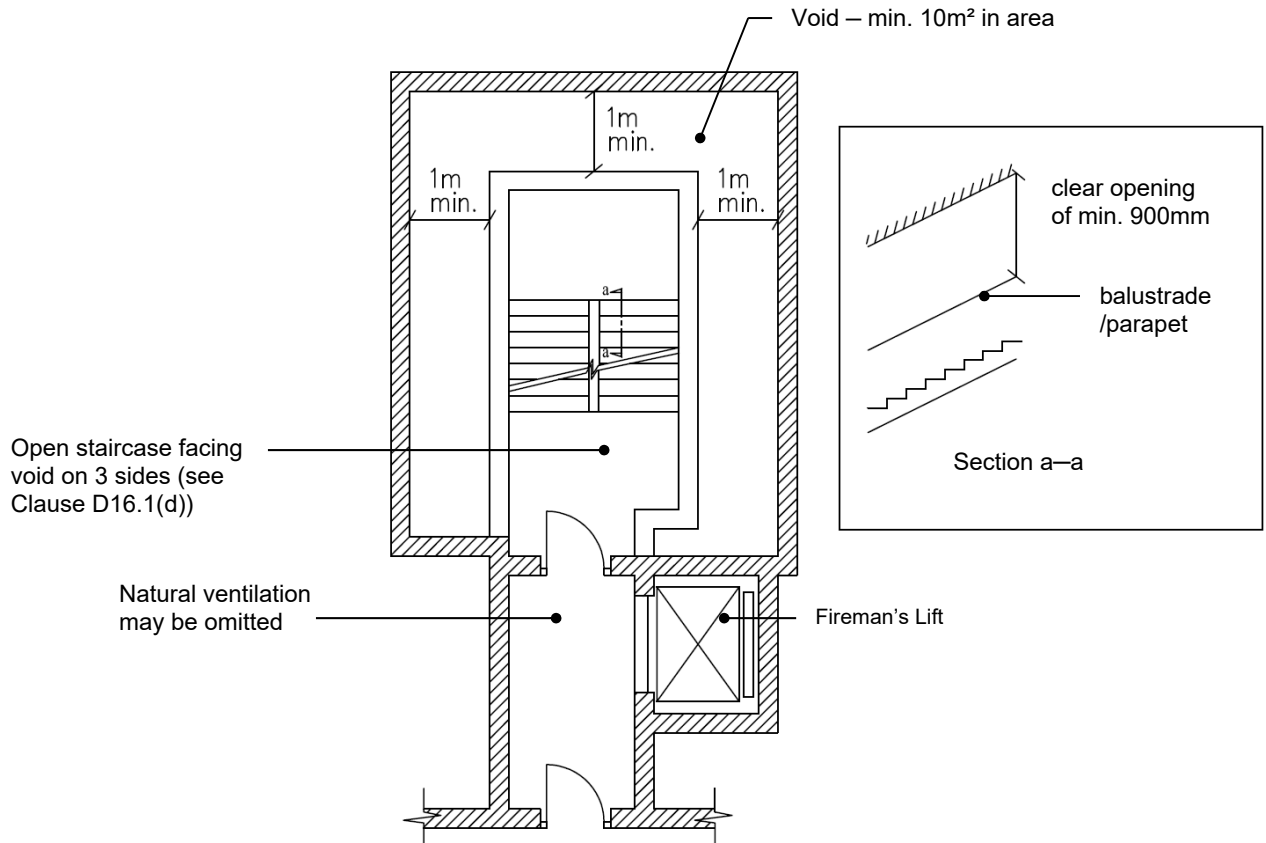



Note:

1. Ventilation may be omitted where a suitable mechanical system, such as pressurization, is provided to the satisfaction of the Director of Fire Services (see Clause D21.1)

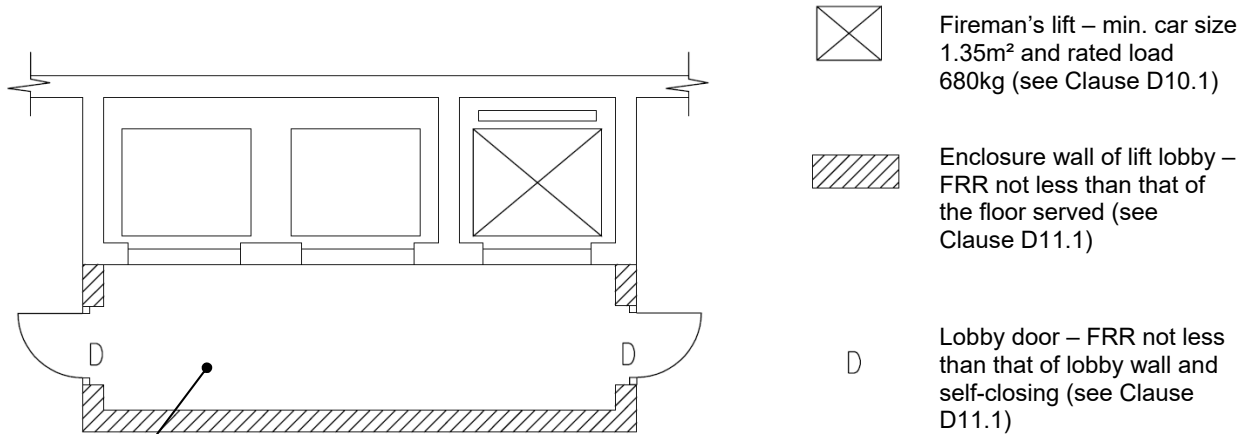
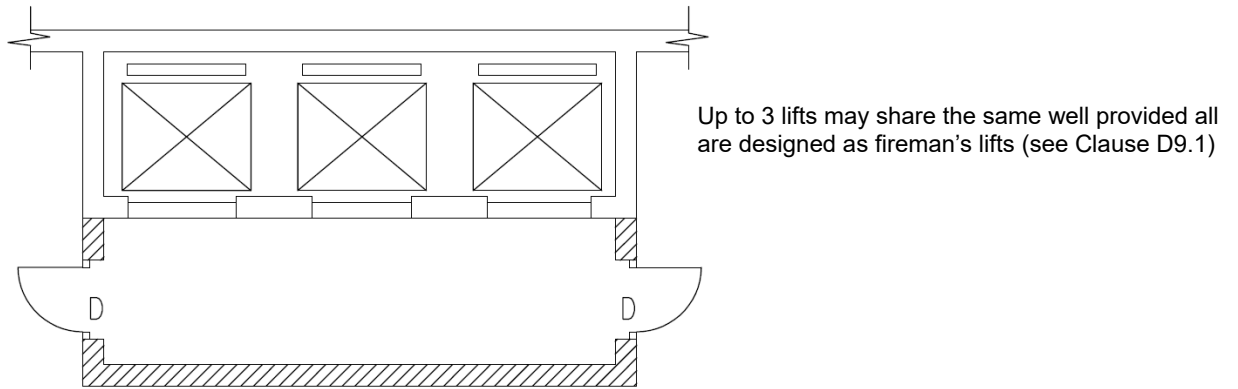
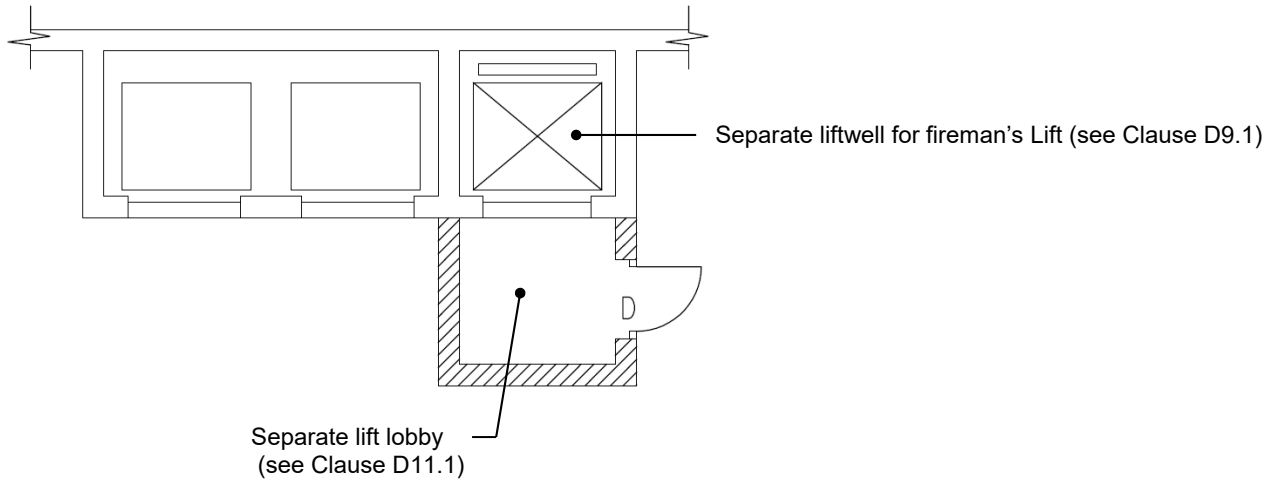
Diagram D3: Fireman's Lift



-  Fireman's lift – min. car size 1.35m² and rated load 680kg (see Clause D10.1)
-  Enclosure wall of lift lobby – FRR not less than that of the floor served (see Clause D11.1)
-  Lobby door – FRR not less than that of lobby wall and self-closing (see Clause D11.1)

Note:

1. Where more than one lift is installed, the Director of Fire Services shall designate the fireman's lift (Clause D6.1)

Diagram D4: Access to a Fireman's Lift at Ground Storey (see Clause D7.2)

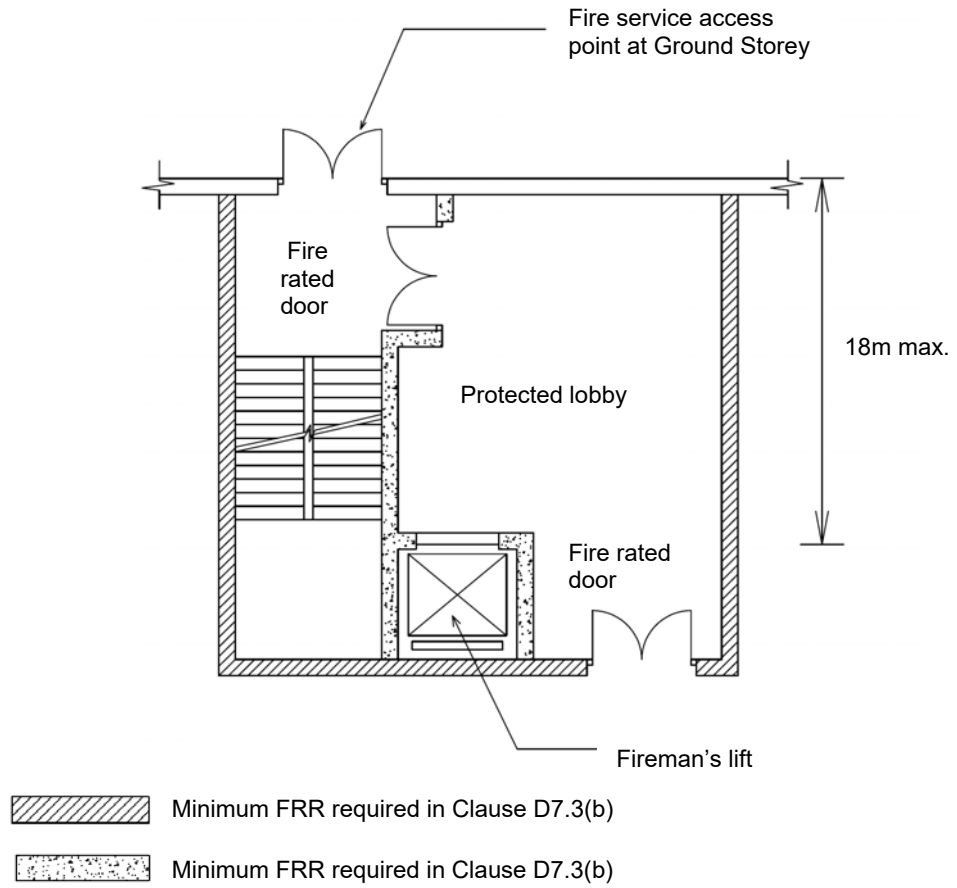

Diagram D5: Requirement on Change in Gradient of EVA (Clause D22.2(c))

Notes:

1. For any change in gradient of EVA, the acute angle α between the two adjoining planes shall not be greater than 6 degrees.
2. In the case of a change in gradient of EVA where the acute angle between the two planes is larger than 6 degrees, there should be provided an intermediate plane of a minimum length of 10m such that the requirement in Note 1 above is complied with, i.e. all the acute angles α between the adjoining planes shall not be greater than 6 degrees.
3. If the intermediate plane is a bend, the plane should be of a minimum length of 12m measured along the centerline of the plane.

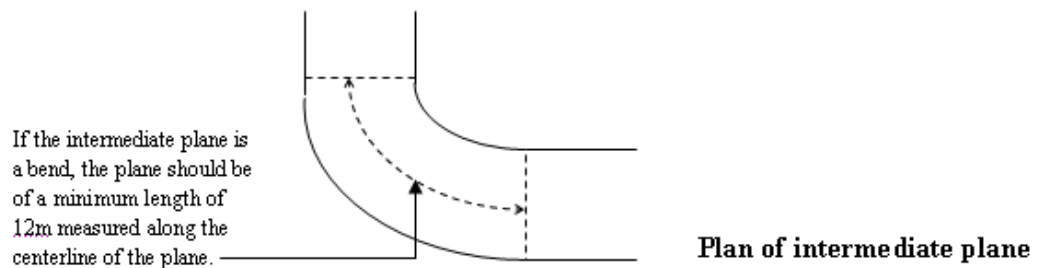
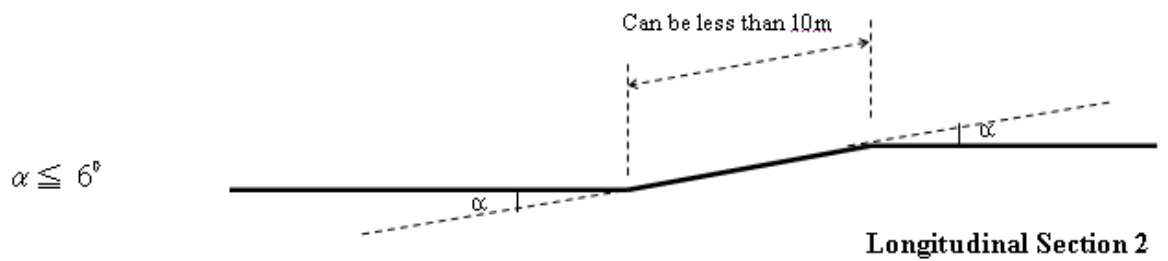
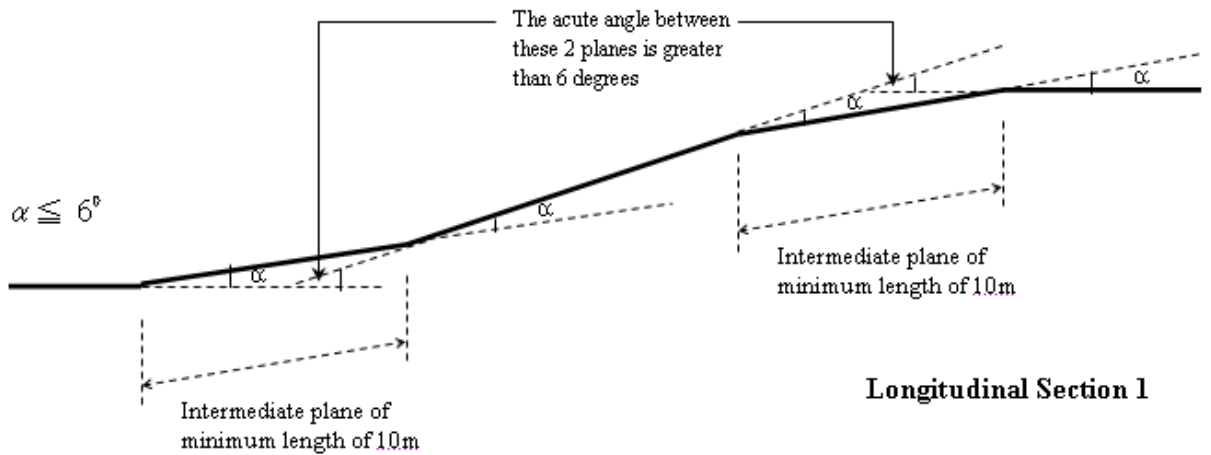
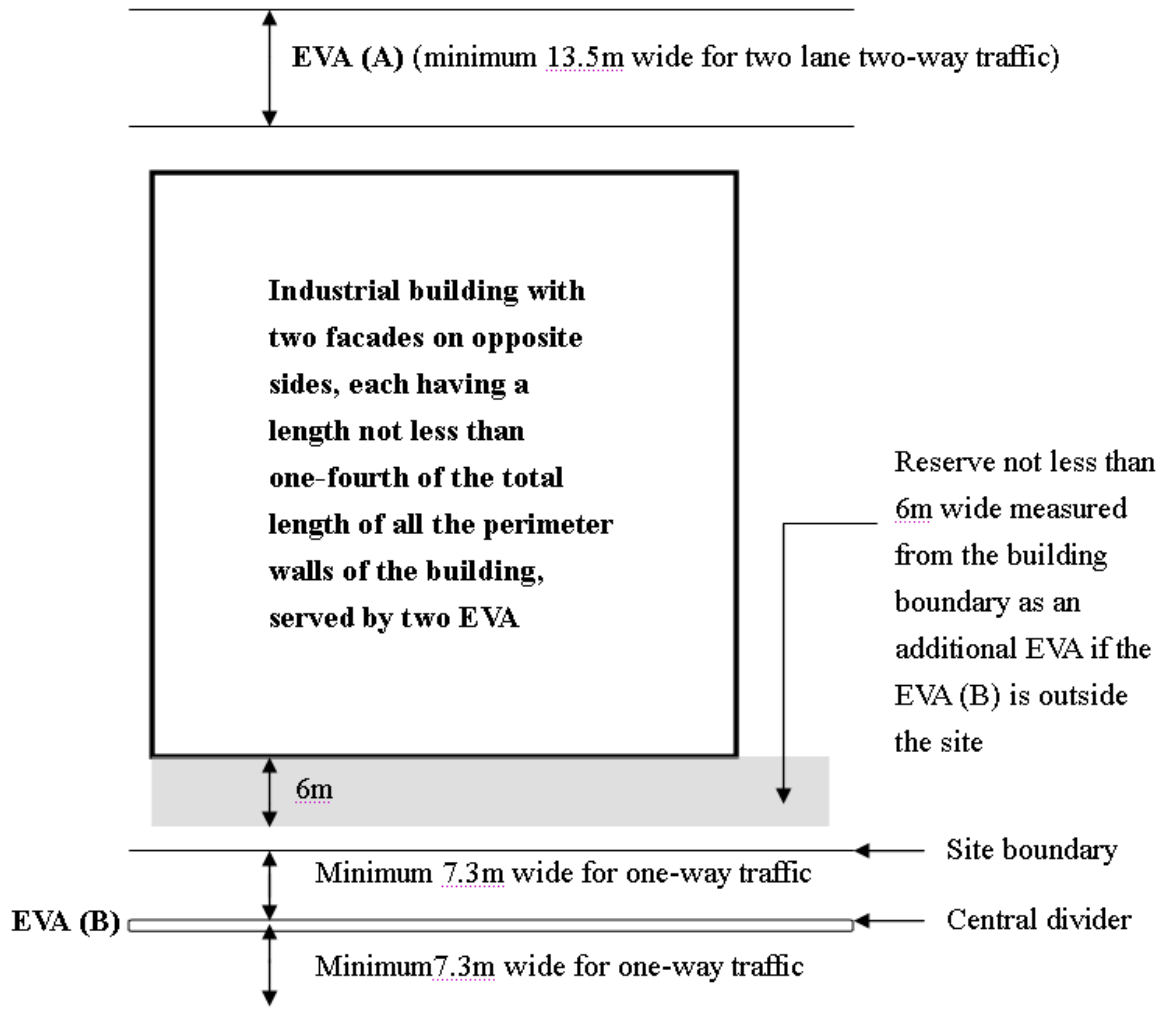

Diagram D6: Requirements of EVA for Buildings for Use Classification 6 in Virgin Sites (Clause D22.3(a))



Note:

1. EVA (A) and EVA (B) should be two separate EVAs if access to the site from more than one street is available.

Diagram D7: Emergency Crash Gate (Clause D22.4)

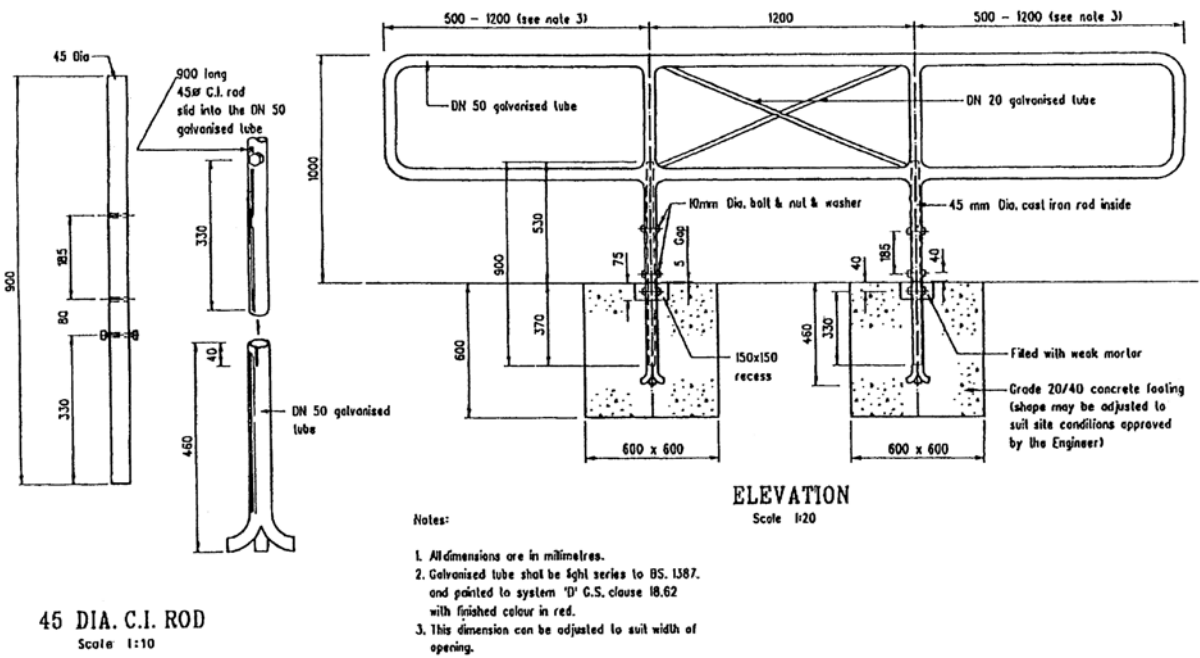

Diagram D8: Provision of Clear Space for Emergency Crash Gate
(Clause D22.4)

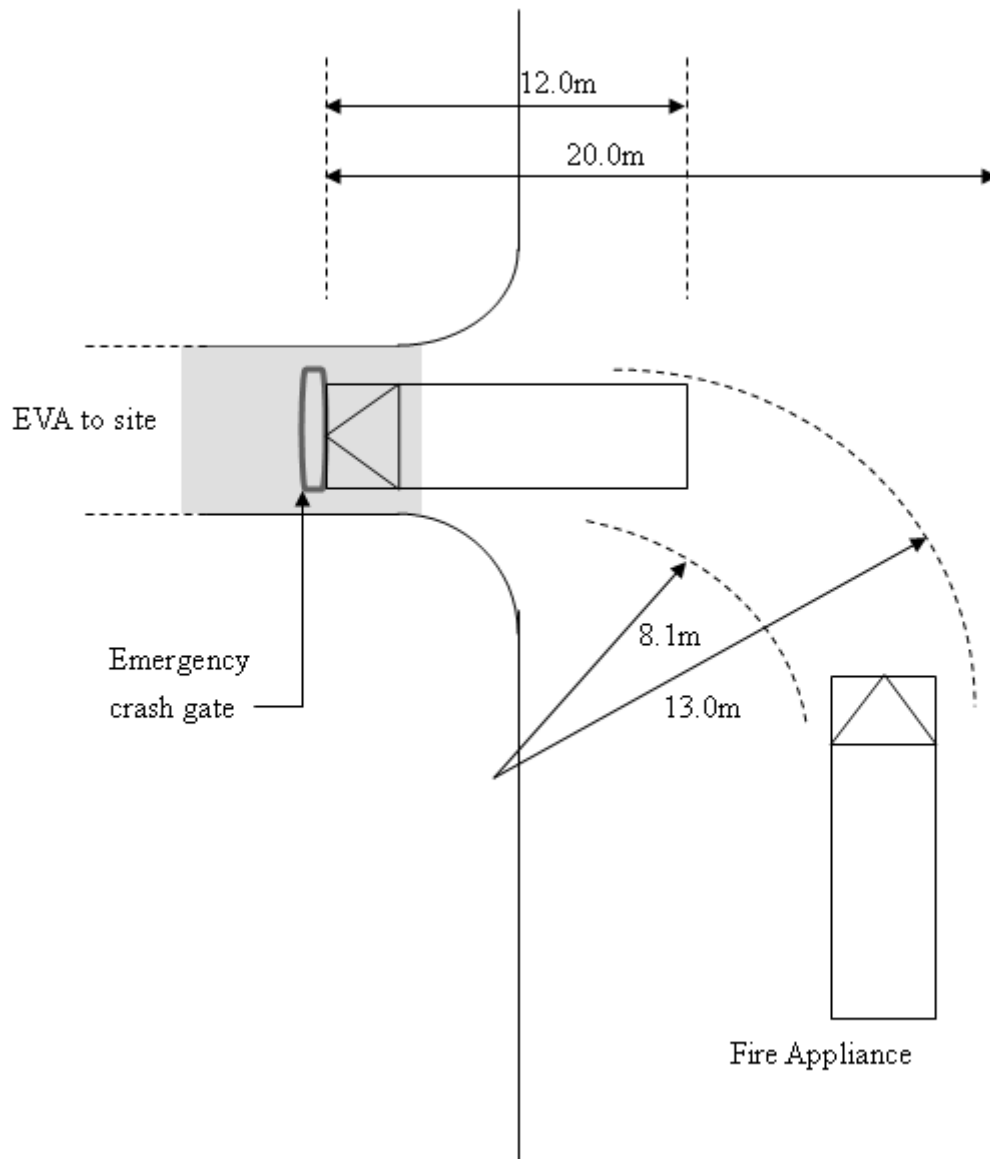

Diagram D9: Layout Sign at Entrance of EVA (Clauses D24.2(a) and D24.3(a))

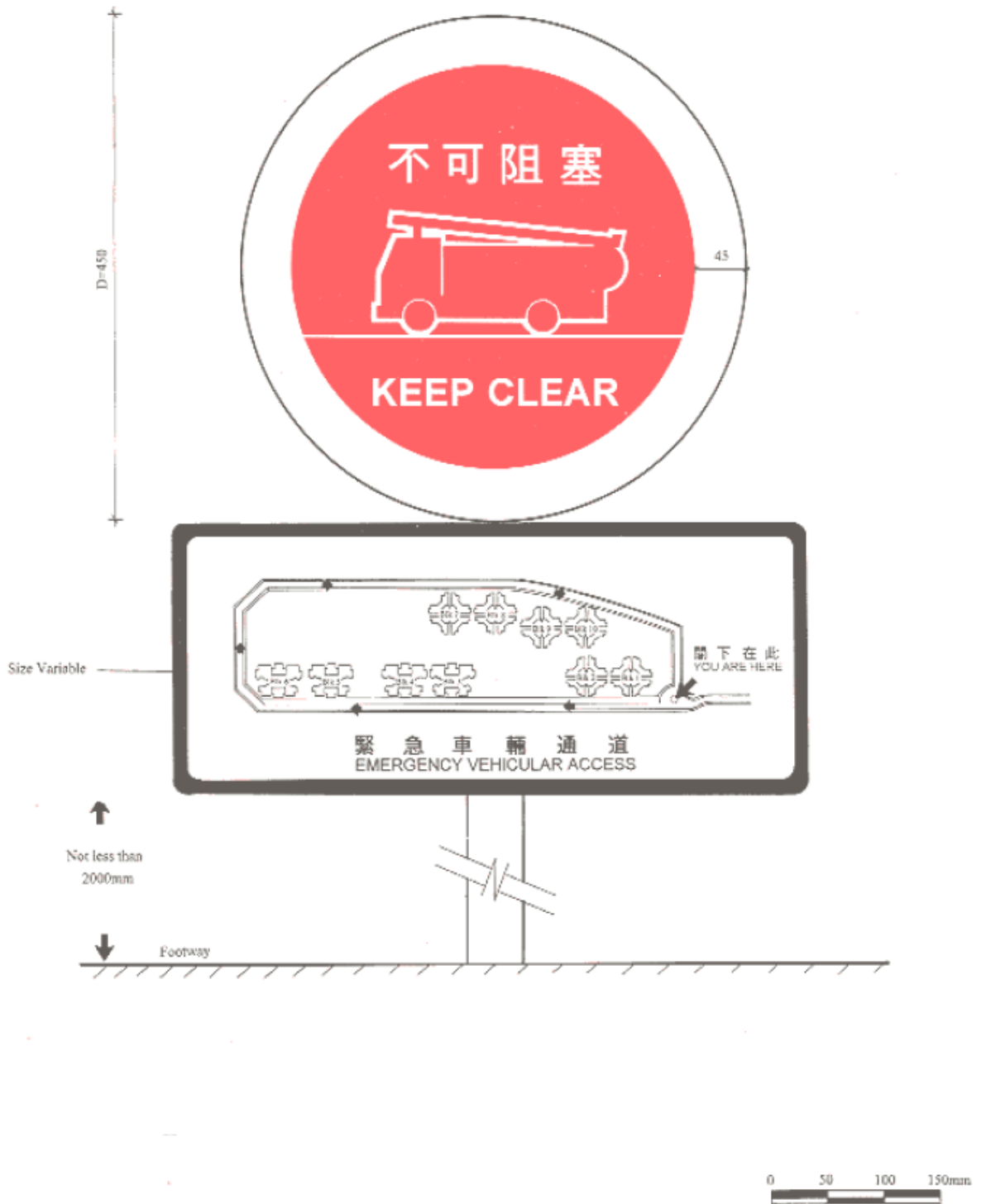
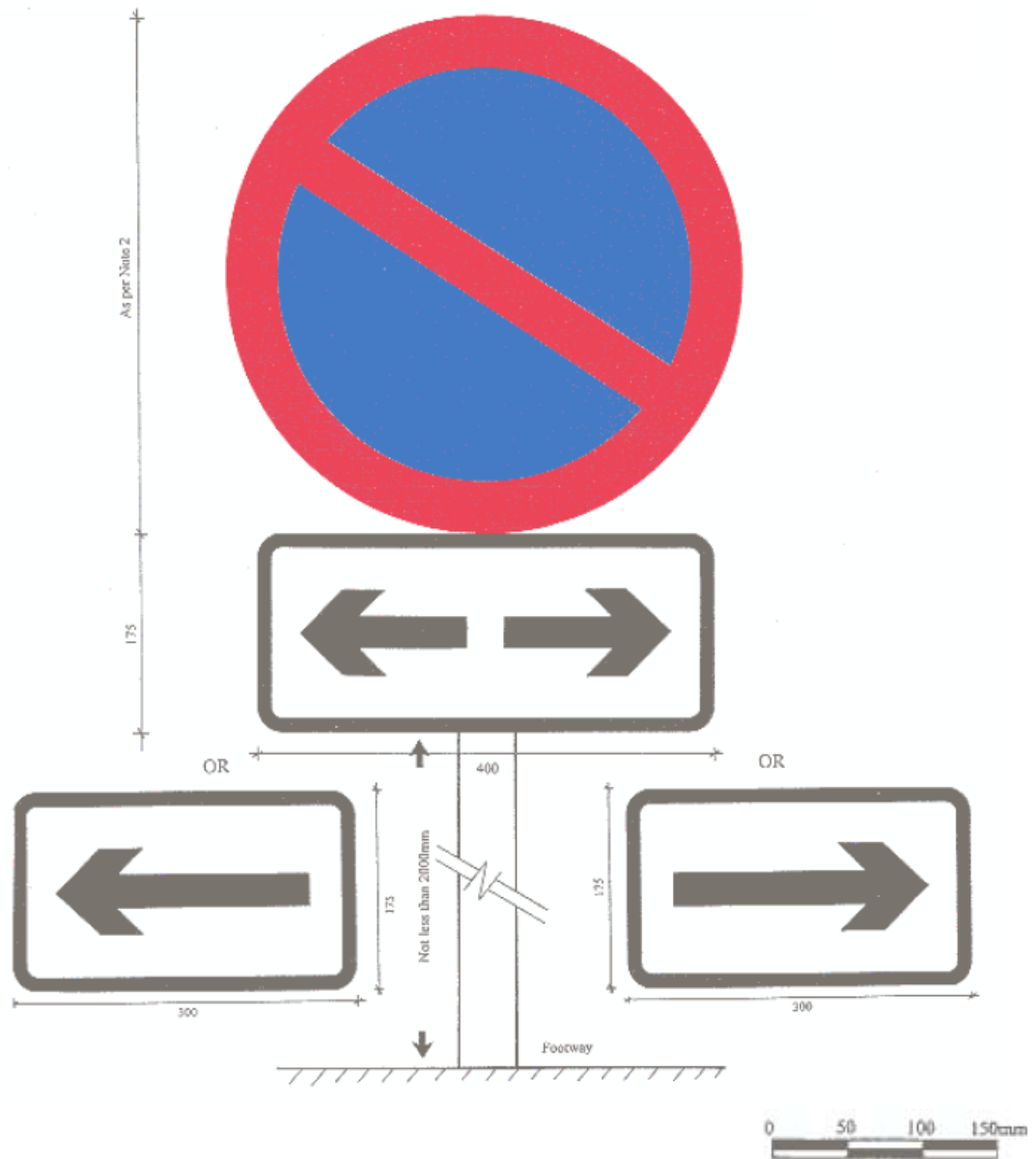

Diagram D10: Indication Sign along EVA in the Form of Carriageway
(Clause D24.2(b))



Diagram D11: No Parking Sign (Clause D24.2(c))



Notes:

1. The specifications of "No Parking" signs shall follow the provisions in Road Traffic (Parking on Private Roads) Regulations, Cap. 374, Laws of Hong Kong and the Code of Practice for Private Roads.
2. The diameter of the "No Parking" sign to be erected at both ends of the EVA shall be 450mm whereas for those in between, signs of 200mm or 300mm diameter may be employed.

Diagram D12: Route Sign Along EVA Not in the Form of Carriageway
(Clause D24.3(b))

