

# Code of Practice for Precast Concrete Construction 2003

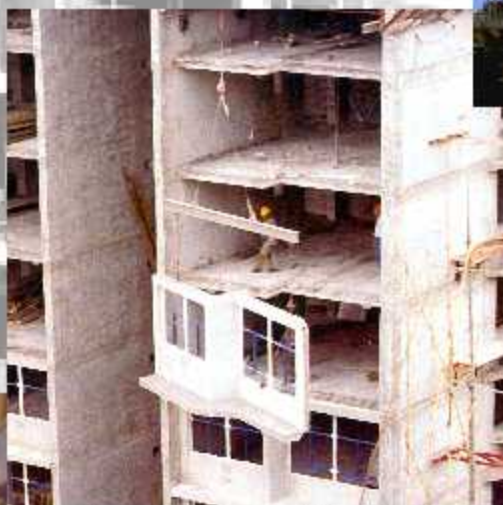

屋宇署  
BUILDINGS  
DEPARTMENT

努力不懈 突破目標  
We Go the Extra Mile

**Code of Practice  
for  
Precast Concrete Construction  
2003**



©The Government of the Hong Kong Special Administrative Region

First Published: October 2003

Prepared by : Buildings Department  
12/F – 18/F, Pioneer Centre  
750 Nathan Road  
Mongkok, Kowloon  
Hong Kong

Consultant : Babtie Asia Ltd.

Steering Committee :

Chairman : Mr Paul T C Pang Buildings Department

Member : Mr K K Choy Buildings Department

Mr Alfred C M Chung Buildings Department

Mr S C Lam Housing Department

Mr Thomas C K Ling Hong Kong Institution of Architects

Dr James C W Lau Hong Kong Institution of Engineers

Mr Thomas T K Choi Hong Kong Institution of Surveyors

Mr Conrad T C Wong Hong Kong Construction Association

Secretary : Mr Stephen Y C Lee Buildings Department

This publication can be purchased by writing to:

Publications Sales Section,  
Information Services Department,  
Room 402, 4<sup>th</sup> Floor, Murray Building,  
Garden Road, Central,  
Hong Kong.  
Fax: (852) 2523 7195

or :

- Calling the Publications Sales Section of Information Services Department (ISD) at (852) 2537 1910
- Visiting the online HK SAR Government Bookstore at <http://bookstore.esdlife.com>
- Downloading the order form from the ISD website at <http://www.isd.gov.hk> and submitting the order online or by fax to (852) 2523 7195
- Place order with ISD by e-mail at [puborder@isd.gov.hk](mailto:puborder@isd.gov.hk)

Price: HK\$32

## **FOREWORD**

This Code of Practice was prepared under the direction of the Hong Kong Buildings Department's Steering Committee on the Consultancy Study on Precast Concrete Construction.

The use of precast concrete construction can significantly reduce the amount of construction waste generated on construction sites, reduce adverse environmental impact on sites, enhance quality control of concreting work and reduce the amount of site labour. This Code of Practice is intended to assist in promoting the use of this construction method by providing guidelines for professionals and practitioners to refer to.

The Code gives recommendations and guidelines on the design, construction and quality control of precast structural and non-structural elements. It has been drafted following an extensive review of international standards and other published literature. It is also based, where applicable, on local experience, practices and relevant standards and codes of practice. It covers the following main areas:

- design and durability, including water tightness of joints;
- construction of precast elements ranging from factory production, transportation and handling through to site erection; and
- quality control for both production and erection.

Although this code is not a statutory document, the compliance with the requirements of this Code of Practice is deemed to satisfy the relevant provisions of the Buildings Ordinance and related regulations.

A list of standards and codes of practice referred to is included in the rear of this document.

## CONTENTS

<b>1</b>	<b>General</b> .....	<b>1</b>
1.1	Scope .....	1
1.2	Definitions.....	1
1.3	Symbols.....	2
<b>2</b>	<b>Design</b> .....	<b>3</b>
2.1	Scope	3
2.1.1	General .....	3
2.1.2	Standards and codes of practice .....	3
2.2	Planning .....	3
2.2.1	Standardisation .....	3
2.2.2	Buildability.....	3
2.2.3	Voids and buried conduits .....	3
2.2.4	Layout plan .....	3
2.2.5	Compatibility .....	4
2.2.6	Demolition .....	4
2.3	Stability.....	4
2.3.1	General .....	4
2.3.2	Displacement .....	4
2.3.3	Disproportionate collapse .....	4
2.4	Durability .....	5
2.4.1	General .....	5
2.4.2	Shape of precast unit.....	5
2.4.3	Concrete cover .....	5
2.4.4	Protection and maintenance of joints and connections .....	5
2.4.5	Movement .....	6
2.4.6	Thermal gradient.....	6
2.4.7	Other effects .....	6
2.5	Loadings.....	6
2.5.1	General .....	6
2.5.2	Demoulding forces.....	6
2.5.3	Handling and transportation.....	7
2.6	Materials.....	7
2.6.1	General .....	7
2.6.2	Alkali-aggregate reaction.....	7
2.6.3	Chlorides in concrete .....	8
2.7	Design considerations .....	8
2.7.1	General .....	8
2.7.2	Handling stresses .....	8
2.7.3	Early lifting of precast element.....	9
2.7.4	Temporary stages/erection sequence .....	9
2.7.5	Lifting inserts.....	9
2.7.6	Bracing design .....	10
2.7.7	Design for movement.....	10
2.7.8	Design of ties .....	10
2.7.9	Design of bearings.....	14
2.8	Joints and connections.....	18
2.8.1	Structural connections .....	18
2.8.2	Water tightness of joints .....	28
2.9	Composite concrete construction.....	41
2.9.1	General .....	41

2.10	Non-structural elements .....	44
<b>3</b>	<b>Construction.....</b>	<b>45</b>
3.1	Production planning .....	45
3.2	Moulds .....	45
3.2.1	Materials .....	45
3.2.2	Tolerances .....	45
3.2.3	Mould orientation .....	46
3.2.4	Recesses, sleeves and boxouts .....	46
3.2.5	Mould release agents .....	46
3.3	Cast-in connections.....	46
3.4	Lifting inserts .....	46
3.4.1	General .....	46
3.4.2	Lifting position tolerances .....	47
3.5	Surface finishes.....	47
3.5.1	Types of finishes.....	47
3.5.2	Production.....	47
3.5.3	Tiled finishes .....	47
3.6	Prefabricated metal frames .....	48
3.7	Pre-concreting check .....	48
3.8	Concrete placing .....	48
3.9	Demoulding and lifting.....	48
3.10	Curing .....	49
3.10.1	Normal curing .....	49
3.10.2	Steam curing.....	49
3.11	Handling.....	49
3.12	Post-concreting check .....	50
3.12.1	General .....	50
3.12.2	Production tolerances .....	50
3.12.3	Surface finish .....	52
3.13	Lifting equipment and accessories .....	52
3.14	Factory and site storage .....	53
3.15	Transportation.....	53
3.15.1	Delivery.....	53
3.15.2	Loading and storage on transporters.....	53
3.16	Erection.....	53
3.16.1	Erection preparation .....	53
3.16.2	Erection safety .....	54
3.16.3	Erection sequence .....	54
3.16.4	Missing or damaged lifting inserts .....	54
3.16.5	Erection tolerances .....	54
3.16.6	Rigging.....	55
3.16.7	Temporary bracing and supporting structures.....	56
3.16.8	Levelling shims .....	56
3.16.9	Propping .....	57
<b>4</b>	<b>Quality Control .....</b>	<b>58</b>
4.1	Factory .....	58
4.1.1	General .....	58
4.1.2	Testing standards .....	58
4.2	Site .....	58

4.3 Special testing .....	59
4.3.1 Watertightness testing of external precast façade panels .....	59
4.3.2 Load testing .....	59
4.3.3 Tiled finishes .....	60

**Appendix A : Precast concrete façade typical details**

## LIST OF TABLES

Table 2.1	– Recommended equivalent load factors to account for demoulding .....	7
Table 2.2	– Recommended equivalent load factors to account for dynamic forces arising during handling, transportation and erection .....	7
Table 2.3	– Limits of chloride content of concrete .....	8
Table 2.4	– Recommended factors of safety for lifting inserts and bracing .....	9
Table 2.5	– Allowances for effects of spalling at supports .....	17
Table 2.6	– Allowances for effects of spalling at supported members .....	17
Table 2.7	– Values of $\tan \alpha_f$ for concrete connections .....	20
Table 2.8	– Classification of sealants, sealing strips, gaskets and baffles .....	28
Table 2.9	– Fillers for movement joints .....	34
Table 2.10	– Design ultimate horizontal shear stresses at interface .....	43
Table 3.1	– Recommended tolerances for lifting devices .....	47
Table 3.2	– Recommended minimum concrete strengths for lifting and handling .....	49

## LIST OF FIGURES

Figure 2.1 – Types of tie in structural frame .....	11
Figure 2.2 – Continuity of ties: bars in precast member lapped with bar in insitu concrete.....	13
Figure 2.3 – Continuity of ties: anchorage by enclosing links.....	14
Figure 2.4 – Continuity of ties: bars lapped within insitu concrete.....	14
Figure 2.5 – Schematic arrangement of allowance for bearing .....	16
Figure 2.6 – Column base plate with base larger than column.....	21
Figure 2.7 – Column base cast into socket.....	21
Figure 2.8 – Beam to beam connection with moment continuity .....	22
Figure 2.9 – Column to column joint with beam passing across.....	22
Figure 2.10 – Column to column connection with beams framing into side .....	23
Figure 2.11 – Column splice using combined welded and bolted connection .....	23
Figure 2.12 – Column splice using welded connection.....	24
Figure 2.13 – Column splice using couplers .....	24
Figure 2.14 – Column splice using grout filled tube.....	25
Figure 2.15 – Wall splice using grout filled tube .....	25
Figure 2.16 – Horizontal wall joints supporting floor slabs.....	26
Figure 2.17 – Horizontal wall joints not supporting floor slabs.....	26
Figure 2.18 – Elevation of vertical wall joints .....	27
Figure 2.19 – Beam and column connection using embedded steel members.....	27
Figure 2.20 – Back-up materials and bond breakers in movement joints.....	30
Figure 2.21 – Typical examples of gaskets in joints .....	32
Figure 2.22 (a) – Gasket junctions: Continuous grid or ladder gasket.....	32
Figure 2.22 (b) – Gasket junctions: Non-continuous gasket.....	33
Figure 2.23 – Single stage horizontal joint between precast wall panels .....	36
Figure 2.24 – Single stage vertical joint between precast wall panels.....	36
Figure 2.25 – Two-stage vertical joints .....	37
Figure 2.26 – Baffle overlap in a two-stage horizontal joint .....	37
Figure 2.27 – Fixing of top of baffle in a two-stage horizontal joint.....	38
Figure 2.28 – Typical intersection between horizontal and vertical two-stage joints in an external wall .....	38
Figure 2.29 – Precast panel to insitu concrete: joint intersection .....	40
Figure 3.1 – Common rigging configurations .....	56

## 1 GENERAL

### 1.1 SCOPE

This Code of Practice deals with the design, construction and quality control of structural and non-structural precast concrete elements. The design method used in this code is the Limit State Design as given in the Code of Practice for the Structural Use of Concrete. Other alternative design approaches may also be used provided sufficient justifying calculations are submitted. For bridges and associated structures, reference should also be made to the Structures Design Manual for Highways and Railways issued by the Highways Department. All design should be carried out under the supervision of a registered structural engineer or authorized person, with the execution of the works carried out under proper supervision. The requirements outlined in this code apply to both structural and non-structural members.

### 1.2 DEFINITIONS

For the purpose of this Code of Practice, the following definitions apply:

<b>Back-up material</b>	Material inserted in a joint that controls the depth and back profile of the applied sealant.
<b>Baffle</b>	Thin strip of flexible material inserted into grooves in a multi-stage joint to prevent the passage of rain/water. Unlike a gasket, a baffle is not compressed to form a seal.
<b>Bearing length</b>	The length of support, supported member or intermediate bedding material (whichever is the least) measured along the line of support (see Figure 2.5).
<b>Bearing width</b>	The overlap of support and supported member measured at right angles to the line of support (see Figure 2.5).
<b>Bedded bearing</b>	A bearing with contact surfaces having an intermediate bedding of cementitious material.
<b>Bond breaker</b>	Film or thin strip of material applied to prevent sealant adhesion to the back of a joint.
<b>Dry bearing</b>	A bearing with no intermediate bedding material.
<b>Elastic sealant</b>	Sealant which exhibits predominantly elastic behaviour, i.e. stresses induced in the sealant as a result of joint movement are almost proportional to the strain.
<b>Elastoplastic sealant</b>	Sealant which has predominantly elastic properties but exhibits some plastic properties when deformed over long periods.
<b>Gasket</b>	Flexible, generally elastic, preformed material that forms a seal when compressed.
<b>Isolated member</b>	A supported member, for which, in the event of failure, no secondary means of load transfer is available.
<b>Joint filler</b>	Compressible, non-adhesive material used to fill movement joints during their construction.
<b>Net bearing width</b>	The bearing width after allowance for ineffective bearing and constructional inaccuracies (see Figure 2.5).

<b>Non-isolated member</b>	A supported member which, in the event of loss of a support, would be capable of transferring its load to adjacent members.
<b>Plastic sealant</b>	Sealant which retains predominantly plastic properties, i.e. the stresses induced in the sealant as a result of joint movement are rapidly relieved.
<b>Plastoelastic sealant</b>	Sealant which has predominantly plastic properties with some elastic recovery when deformed for short periods.
<b>Seal</b>	Notionally impenetrable physical barrier in contact with the components forming the joint.
<b>Sealant</b>	Material, applied in an unformed state to a joint, which seals it by adhering to appropriate surfaces within the joint.
<b>Sealing strip</b>	Preformed material, which may have adhesive properties, that forms a seal when compressed between adjacent joint surfaces.
<b>Simple bearing</b>	A supported member bearing directly on a support, discounting the effect of projecting steel or added concrete.

### 1.3 **SYMBOLS**

For the purposes of this Code of Practice, the following symbols apply:

$G_k$	characteristic dead load
$Q_k$	characteristic imposed load
$f_{cu}$	characteristic strength of concrete
$f_y$	characteristic strength of reinforcement

Other symbols are defined in the text where they occur.

## **2 DESIGN**

### **2.1 SCOPE**

#### **2.1.1 General**

The considerations for design and detailing of structural and non-structural precast elements including joints and connections for buildings and building works are given in this section.

#### **2.1.2 Standards and codes of practice**

Precast concrete elements should be designed and constructed in compliance with the Building (Construction) Regulations and other relevant codes of practice.

The design method specified in this code of practice for the design of precast concrete elements is the Limit State Design method. Other alternative design approaches may be used provided that sufficient justifications are given. Unless otherwise specified, the design considerations and detailing requirements recommended in the Code of Practice for the Structural Use of Concrete should be followed.

### **2.2 PLANNING**

#### **2.2.1 Standardisation**

Buildings utilising precast concrete construction should be planned wherever possible to utilize standardised precast concrete elements.

Most buildings will be unique and site specific. At the conceptual design stage, a basic layout plan should be developed which achieves a balance between architectural/aesthetic requirements and a high degree of standardisation. Therefore, close collaboration amongst different design parties is essential during conceptual design to achieve the optimum standardisation.

#### **2.2.2 Buildability**

Overall planning and detailed design should aim to achieve functionality with ease of construction.

During conceptual design, consideration should be given to the following:

- ease/ means of transportation and any restrictions on vehicle size;
- access to and around the site;
- ease of erection;
- size and capacity of crane available to undertake erection;
- propping and/or bracing requirements;
- joint widths between adjacent precast elements should be sufficient to allow safe alignment during erection and to accommodate building movement and construction tolerances;
- jointing method;
- structural action; and
- cost of construction.

In addition, attention should be given to any special considerations affecting large sized panels particularly with regards to fabrication, de-moulding and transportation.

#### **2.2.3 Voids and buried conduits**

Where practical all voids and service openings should be preformed. Cast in/buried conduits should be placed within the reinforcement layers of the pre-cast unit.

#### **2.2.4 Layout plan**

Structural layout plans should be a complete and comprehensive set of drawings showing plans, sections, elevations and connection details of the different types of precast components used.

## **2.2.5 Compatibility**

Whenever there are divided responsibilities for design and details in precast construction, detailed checks to ensure compatibility should be made by a designated party.

## **2.2.6 Demolition**

Consideration should also be given at planning stage to future demolition of the structure and any special requirements that are needed particularly with regards to prestressed structures.

## **2.3 STABILITY**

### **2.3.1 General**

The overall stability of the complete structure must be checked.

The temporary stability of the structure as well as that of the individual components during all stages of construction should also be considered.

A structure comprising precast elements must possess adequate stability to resist wind load and other lateral loads. Cross walls or sway frames should be so arranged, as far as practicable, so as to provide lateral stability.

Many precast concrete structures are designed as pin jointed rather than with moment continuity as is the case with insitu concrete frames. The absence of the rigid frame means that, in the case of buildings, transverse stability is generally provided by shear walls, with floors transferring load by acting as horizontal plates. It is therefore essential to provide adequate ties between elements.

If wind load does not govern, stability should be checked for a minimum notional horizontal force acting at each floor level equals to 1.5% of the characteristic dead load between mid-heights of the storey under and above or the roof surface, as appropriate.

Consideration should also be given to lateral stability during all stages of construction and erection where the behaviour of the precast elements may differ from the permanent condition. Adequate propping and bracing should be provided at all stages of construction to ensure stability is maintained at all times. A viable scheme showing how temporary stability is provided at each construction stage should be produced. The temporary works scheme should provide sufficient details including propping layouts for all stages of construction including the sequencing and timing of the dismantling of temporary works.

Particular attention should be given to stability and bracing requirements on high risk structures such as long span beams and high rise buildings.

### **2.3.2 Displacement**

#### *2.3.2.1 General*

Structural members should possess adequate stiffness to prevent such deflection or deformation as might impair the strength or efficiency of the structure, or produce cracks in finishes or in partitions. The structure as a whole should possess adequate stiffness such that the maximum lateral deflection due solely to wind forces does not exceed 1/500 of the building height. In determining the total lateral deflection, an allowance should be included for the cumulative effects of deformation of connections (see clause 2.3.2.2).

#### *2.3.2.2 Connection deformation*

In determining the overall lateral displacement allowance must be made for slippage and deformation of connections in all structural elements. The cumulative value of deformation of connections at each level should be added to the deflection calculated from the structural analysis and the total value should comply with the limitation specified in clause 2.3.2.1.

### **2.3.3 Disproportionate collapse**

Precast building structures should also be checked for disproportionate collapse as a result of progressive failure or the like.

## **2.4 DURABILITY**

### **2.4.1 General**

It is important to consider the required design life and durability of precast elements. For this purpose, the following factors are be considered:

- shape and size of the precast unit;
- concrete constituents;
- concrete cover;
- the environmental exposure;
- protection against fire;
- protection and maintenance;
- production;
- transportation, storage and installation; and
- design of joint details.

In addition to the requirements given above, the recommendations specified in the Code of Practice for the Structural Use of Concrete and the Building (Construction) Regulations should be followed.

### **2.4.2 Shape of precast unit**

The precast unit should be designed and detailed to have good drainage such that no standing pools or excessive trapped moisture would occur.

Sharp corners or sudden changes in section cause stress concentrations that may lead to cracking or spalling and therefore should be avoided. Where sharp corners or sudden changes in section cannot be avoided because of practical reasons, stress concentrations should be checked and strengthening be provided as necessary.

### **2.4.3 Concrete cover**

Cover for precast elements should be no less than those specified for reinforced concrete structures.

In respect of concrete cover requirements for protection against fire, the Code of Practice for Fire Resisting Construction should be followed, whereas for protection against corrosion, the requirements under the Building (Construction) Regulations should be adopted.

For bridges and associated structures, reference should also be made to the requirements specified in the Highways Department's Structures Design Manual for Highways and Railways, and the most onerous requirements should be used.

The cover to all brackets and fixings etc should comply with the minimum cover requirements specified for reinforcement.

The fire resistance of joints fillers etc should comply with the fire resistance requirements of the precast members.

### **2.4.4 Protection and maintenance of joints and connections**

#### *2.4.4.1 General*

To achieve durability, connections should be properly filled with suitable material to prevent corrosion, cracking or spalling of concrete.

#### *2.4.4.2 Protection of steel*

Steel used at connections should be protected with an adequate thickness of concrete, mortar or grout. The effectiveness of bonding of concrete or grout to steel surfaces must be considered.

#### *2.4.4.3 Protection of fixings*

If sufficient concrete cover cannot be provided to protect the fixings at connections, corrosion-resisting materials such as galvanised mild steel or stainless steel shall be used.

#### 2.4.4.4 *Maintenance accessibility*

The importance of the connection and its readiness for inspection usually dictate the type of protection required. Connections that are not accessible for inspection should be properly protected from corrosion.

#### 2.4.5 **Movement**

To avoid spalling and cracking, allowance should be made for movement (see clause 2.7.7).

#### 2.4.6 **Thermal gradient**

Reinforcing steel preventing cracking of concrete should be provided in both faces of panels that are subjected to substantial thermal gradients.

#### 2.4.7 **Other effects**

Indirect effects resulted from loading changes, temperature differentials, creep, shrinkage, etc can affect the behaviour of structures.

Apart from compliance with general requirements for durability, cracking and deformation, strength and stability, the following may have to be considered:

- limiting the cracking and deformation arising from early-thermal movement, creep, shrinkage, etc; or
- minimising restraints on structural components by providing bearings or movement joints, or if restraints are inevitable, the design should take into consideration any significant effects that may arise.

### 2.5 **LOADINGS**

#### 2.5.1 **General**

The appropriate loads as specified in the Building (Construction) Regulations and the relevant codes of practice should be used.

Design considerations should also be given to:

- construction loads. A minimum load of 1.5 kN/m<sup>2</sup> should be used. However, due consideration should be given to any special requirements e.g. for plant loads or storage loads and the load increased accordingly;
- notional horizontal load. The lateral load should be taken as not less than 1.5% of the characteristic dead load (refer also to clause 2.3.1); and
- accidental loads such as earth movement, impact of construction vehicles.

#### 2.5.2 **Demoulding forces**

An allowance should be made for the forces on the element due to suction or adhesion between the precast element and the mould when precast elements are lifted from a casting bed. These are accounted for by applying an equivalent load factor to the member self weight and treating it as an equivalent static force to evaluate the stresses in the precast element against the commensurate early strength attained. Table 2.1 gives recommended values of equivalent load factor for demoulding forces for different product types and finishes.

**Table 2.1 – Recommended equivalent load factors to account for demoulding**

Product type	Finish	
	Exposed aggregate with retarder	Smooth mould (form oil only)
Flat with removable side forms. No formed rebates or reveals	1.2	1.3
Flat with removable side forms. Formed rebates or reveals	1.3	1.4
Fluted with proper draft	1.4	1.6
Sculptured	1.5	1.7
Notes: 1. These factors are to be applied to the flexural design of precast elements only. For lifting inserts, refer to Table 2.4 2. The above values are recommended values only. Guidance should also be sought from the precast manufacturer to verify their suitability. 3. The associated liveloads or windloads, if any, are to be assessed and considered under the appropriate load combination.		

### 2.5.3 Handling and transportation

An allowance should be made for dynamic loads and impact forces arising during handling, transportation and erection. Similar to demoulding force consideration, Table 2.2 gives recommended values for equivalent load factor to be applied to the member self weight to allow for these forces.

**Table 2.2 – Recommended equivalent load factors to account for dynamic forces arising during handling, transportation and erection**

Stage	Load factor
Yard handling	1.2
Transportation	1.5
Erection	1.2
Notes: 1. These factors are to be applied to the flexural design of precast elements only. For lifting inserts, refer to Table 2.4 2. The above values are recommended values only. Under certain conditions higher factors may apply i.e. certain unfavourable road conditions. 3. The associated liveloads or windloads, if any, are to be assessed and considered with the appropriate load combination.	

## 2.6 MATERIALS

### 2.6.1 General

For the requirements on the use of materials, the Building (Construction) Regulations should be followed. The material properties used for design should be obtained from the Code of Practice for The Structural Use of Concrete.

### 2.6.2 Alkali-aggregate reaction

#### 2.6.2.1 Alkali-silica reaction

Aggregates containing silica minerals are susceptible to attack by alkalis ( $\text{Na}_2\text{O}$  and  $\text{K}_2\text{O}$ ) from the cement or other sources. Alkali-silica reaction causes cracking and reduces the strength of concrete.

Effective means of reducing the risk of alkali aggregate reaction include:

- control on the amount of cement used in the concrete mix;
- use of a low alkali cement;
- use of an appropriate cement replacement such as pulverised fuel ash (pfa); and

- the reactive alkali content of concrete expressed as the equivalent sodium oxide per cubic metre should not exceed 3.0 kg.

The concrete supplier should submit to the authorized person or registered structural engineer a mix design and Hong Kong Laboratory Accreditation Scheme (HOKLAS) endorsed test certificates giving calculations and test results demonstrating that the mix complies with the above limitation on reactive alkali content.

#### 2.6.2.2 *Alkali-carbonate reaction*

Some carbonate aggregates may be susceptible to alkali-carbonate reaction, which is similar to alkali-silica reaction in its effects. If carbonate aggregates are to be used, specialist advice should be obtained.

### 2.6.3 Chlorides in concrete

Reinforcing steel is susceptible to corrosion with the presence of chloride in concrete.

The total chloride content of the concrete mix arising from the aggregate, admixtures and any other source should not exceed the limits given in Table 2.3.

The total chloride content should be calculated from the mix proportions and the measured chloride contents of each mix constituent.

**Table 2.3 – Limits of chloride content of concrete**

Type or use of concrete	Maximum total chloride content expressed as a percentage of chloride ion by mass of cement * (%)
Prestressed concrete Steam-cured concrete	0.10
Concrete made with sulphate resistant cement	0.20
Concrete with embedded metal and made with Ordinary or Rapid Hardening Portland cement	0.35
* inclusive of pulverised fuel ash or ground granulated blast furnace slag when used	

## 2.7 DESIGN CONSIDERATIONS

### 2.7.1 General

The recommended methods for design and detailing of reinforced concrete and prestressed concrete given in the Code of Practice for the Structural Use of Concrete also apply to precast concrete elements. In addition, the following should also be considered:

- handling stresses;
- early lifting of precast element;
- temporary stages / erection sequence;
- lifting inserts;
- bracing design;
- design for movement;
- design of ties; and
- design of bearings.

### 2.7.2 Handling stresses

Precast units should not be inflicted with any permanent damage arising from their handling, storage, transportation and erection. Consideration should be given during design to:

- loads on erected elements at construction stage (refer to clause 2.5.1); and
- demoulding, storage, transportation and erection of precast units on site (refer to clauses 2.5.2 and 2.5.3).

### 2.7.3 Early lifting of precast element

Where precast elements are lifted and handled prior to gaining full strength the elements together with any lifting inserts should be designed accordingly. Recommended minimum concrete strengths for lifting and handling of precast elements are given in Table 3.2. Precast elements should be designed, using these lower strengths, to span between lifting points without excessive cracking or deflection.

For prestressed concrete, consideration should also be given to stresses resulting from transfer of prestressing forces.

### 2.7.4 Temporary stages/erection sequence

The critical loading for precast elements is often not the permanent condition but can occur during the construction phase and, hence, the temporary condition may govern the design of elements. Consideration should be given to the loading imposed on precast elements during each phase of construction. Examples of such cases are as follows:

- precast sections of composite elements which are required to support self weight plus construction load prior to casting of an insitu topping;
- lower precast floor slabs or precast stair flights which support propping to upper levels during installation; and
- bearing or halving joints which support higher temporary construction loads because of back propping to upper levels.

The design should also take into consideration that the structural action and framing might be different during the temporary stages resulting in higher stresses in individual members.

### 2.7.5 Lifting inserts

#### 2.7.5.1 General

When determining the number and location of lifting inserts, the following should be considered:

- lifting insert capacity (safe working load);
- total weight of the element;
- strength of concrete at age of lifting (see clause 2.7.3);
- shape of the unit;
- location of the inserts so that the failure of any one insert does not cause failure of the entire lifting system thereby ensuring the element can still be safely supported;
- position of any cut-outs and/or openings; and
- rigging arrangement.

All lifting inserts should be purpose designed proprietary products. Reinforcing bars may only be used as lifting inserts if specifically designed and installed for this purpose.

Table 2.4 gives recommended factors of safety at ultimate limit state for designing of lifting inserts.

Typically, lifting inserts should be designed with a factor of safety of 4. Where, they are to be used for multiple lifts such as manhole covers, a factor of safety of 5 should be used. These factors are at ultimate limit state.

Lifting inserts should be tested or evidence of testing of inserts to the ultimate load should be provided.

**Table 2.4 – Recommended factors of safety for lifting inserts and bracing**

Item	Recommended factor of safety
Bracing members	2
Bracing connections	3
Bracing inserts cast into precast members	3
Lifting inserts, normal circumstances	4
Lifting inserts, multiple usage	5

### 2.7.5.2 *Anchorage*

All lifting inserts require adequate embedment or anchorage to function effectively. Factors affecting anchorage include the following:

- proximity to element edges, openings, rebates or arrises;
- proximity to other concurrently loaded lifting devices;
- concrete strength at lifting;
- concrete thickness;
- depth of embedment;
- presence of cracking;
- proximity of reinforcement or pre-stressing tendons; and
- tensile stresses in the concrete around the insert.

Guidance should be sought from the manufacturer when determining the safe working load of the inserts taking into consideration the above factors.

### 2.7.5.3 *Additional reinforcement*

Where additional reinforcement is required in the vicinity of the insert to generate the full load capacity of the insert, it should be detailed in accordance with the Code of Practice for the Structural Use of Concrete and the manufacturer's recommendations.

### 2.7.6 **Bracing design**

Bracing should be designed for both construction and wind loading. The construction load should be a minimum value of 1.5 kN/m<sup>2</sup> but should be increased if considered appropriate.

Wind loads should be calculated in accordance with the Code of Practice on Wind Effects.

Recommended load factors for design of bracing and connections are given in Table 2.4.

### 2.7.7 **Design for movement**

Provision for movements is of great importance in precast construction. The type, number and spacing of joints should be determined at an early stage in the design and will be dependent upon the cumulative movement expected. In determining the width of the joint, allowance should also be made for production and erection tolerances (refer to clauses 3.12.2 and 3.16.5). Causes of movements in structures includes the following:

- creep deformations;
- early thermal shrinkage;
- long term shrinkage;
- differential settlement;
- thermal movement due to seasonal changes of temperature; and
- thermal movement due to temperature difference between internal and external environments.

When determining the range of movement for a particular joint, it should be borne in mind that not all movements are coexistent and the timescale over which different types of movement will occur should be taken into consideration. Also, due regard should be given to ambient temperature and age of precast elements and stage of construction at the time of formation of the joint.

The designer should also take into account the effects of eccentric moments caused by eccentricities from production and erection tolerances and cumulative moments at joints.

### 2.7.8 **Design of ties**

#### 2.7.8.1 *General*

To allow for damage or prevent progressive failure due to accidental loads which may result in the failure of a load bearing element, horizontal and vertical ties (or their equivalent) must be provided. Such ties provided should be continuous, and may be within the insitu concrete topping, or precast units, or partly within both the precast and insitu concrete. The various types of ties are to be designed to resist the minimum tensile forces as defined in clauses 2.7.8.4 to 2.7.8.8.

The tying requirements specified in this clause are in addition to other design requirements due to gravity, wind or any other design loads.

2.7.8.2 *Provision of ties*

Tie reinforcement should be designed to resist forces mentioned in clauses 2.7.8.4 to 2.7.8.8 whereas reinforcement that is provided for other purposes may be increased in quantity to act as ties. A material partial safety factor of 1 can be used when determining the area of reinforcement required.

2.7.8.3 *Types of ties*

The types of ties to be provided for stability and interaction between precast units are as follows:

- internal ties;
- peripheral ties;
- horizontal ties to column and walls;
- corner column ties; and
- vertical ties to columns and walls.

Figure 2.1 shows a typical example of ties in building structures.

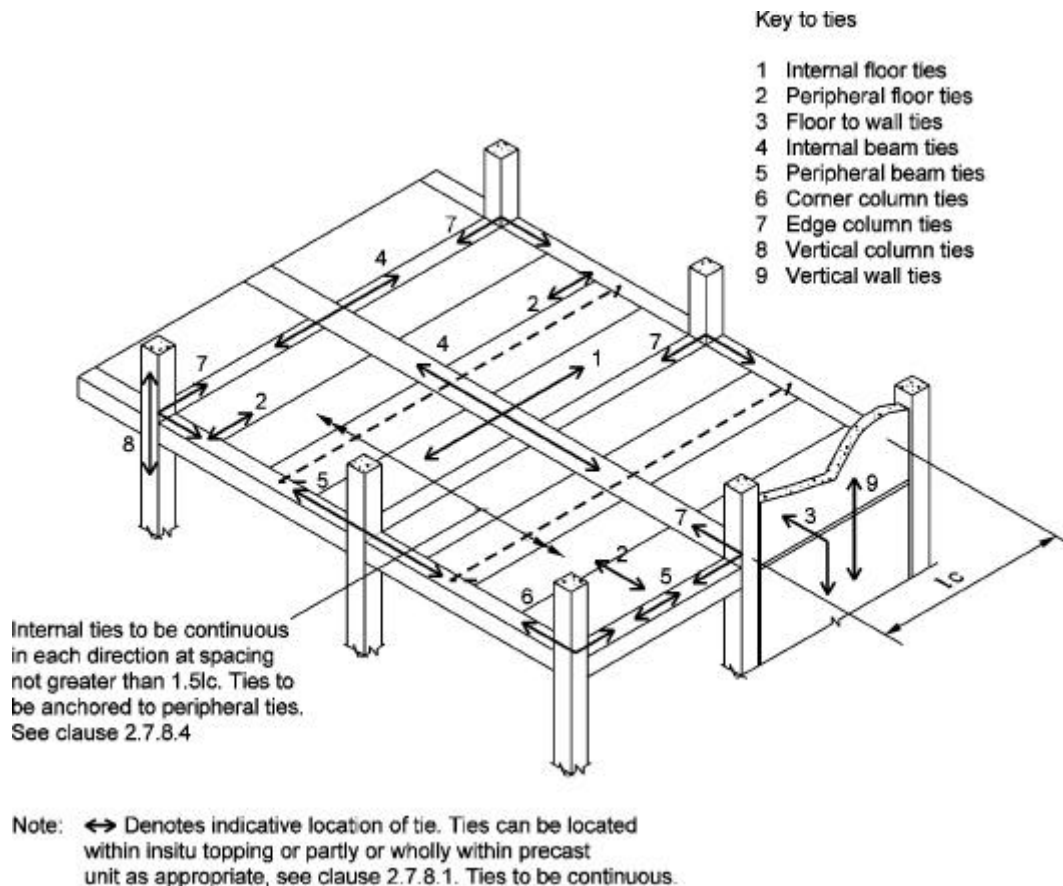

**Figure 2.1 – Types of tie in structural frame**

#### 2.7.8.4 Internal ties

(a) Distribution

At each floor and roof, internal ties should be provided in two perpendicular directions. They should be continuous and except for horizontal ties to walls or columns they should be anchored to the peripheral ties at each end. They may be distributed evenly in the slabs or grouped in walls or at other suitable locations. Their spacing should generally be not greater than  $1.5 l_c$  ( $l_c$  equals the span length in the directions of the ties (in m) between the centres of the columns, frames or walls whichever greater). In walls, they should be within 0.5m of the top and bottom of floor slabs.

(b) Strength

Ties should be designed to resist, in each direction, a tensile force,  $T$  (in kN/m), equal to the greater of:

$$T = \frac{G_k + Q_k}{7.5} \times \frac{l_c}{5} \times F \quad ; \text{ or}$$

$$T = 1.0F$$

where:

$G_k$  is the average characteristic dead floor load (in kN/m<sup>2</sup>);

$Q_k$  is the average characteristic imposed floor load (in kN/m<sup>2</sup>)

$l_c$  is as defined in 2.7.8.4 (a)

$F$  is defined as the lesser of  $(20 + 4n)$  or 60 where  $n$  is the number of storeys.

For structures with single direction cross or spine walls, the length  $l_c$  for calculating the tie force in the direction of the wall should be the lesser of the actual length of the wall or the collapsed length in case of an accident. The collapsed length should be the distance between adjacent lateral supports or between a lateral support and a free edge, of the wall under consideration.

#### 2.7.8.5 Peripheral ties

Peripheral ties should be provided at each floor and roof level for resisting a tension of  $1.0 F$  (in kN per metre width). The peripheral ties should be placed within 1.2 m of the edge of the building or within the peripheral wall.

#### 2.7.8.6 Horizontal ties to columns and walls

Every metre length of external bearing wall, unless the peripheral tie is located within that wall, should be anchored or tied horizontally into the structure at each floor and roof level. Every such tie should be able to resist a tension (in kN) equals to the greater of:

- the lesser of  $2.0 F$  or  $\left(\frac{h}{2.5}\right)F$  where  $h$  (in m) is the clear storey height; or
- 3% of the total design vertical load of the column or wall at that level.

Where the peripheral tie is placed within the wall or column, only horizontal ties or anchors as required in clause 2.7.8.4 need to be provided.

#### 2.7.8.7 Corner column ties

Corner columns should be tied into the structure at each floor level in orthogonal directions as far as practicable. The ties should each be able to resist a force as calculated in accordance with clause 2.7.8.6.

#### 2.7.8.8 Vertical ties to columns and walls

Each bearing wall or column should be tied continuously at all levels. The tie should be able to resist a tensile force equal to the maximum design dead and imposed load at the column or wall from any one storey.

### 2.7.8.9 Tie anchorage

A tie crossing another tie at right angles may be considered anchored if the bars extend:

- 12 times the bar diameter or an equivalent anchorage beyond the other tie; or
- an effective anchorage length, calculated from the tension force, beyond the centre-line of the other tie.

At abrupt changes in construction or at re-entrant corners, it is necessary to ensure that the ties are sufficiently anchored or to be made effective by other means.

### 2.7.8.10 Continuity of ties

A continuous tie must satisfy clause 2.8.1.3. The minimum thickness of insitu concrete section where tie bars are provided should be at least the total dimension of the bar diameter (or two diameters at laps) and twice the maximum aggregate size plus 10 mm.

To provide continuity the tie should also satisfy one of the following:

- a bar in a precast concrete unit lapped with a bar encased in insitu concrete bounded on two opposite sides by rough faces of the same precast unit (see Figure 2.2);
- a bar in a precast concrete unit lapped with a bar encased in the topping of insitu concrete tied to the precast unit by links or stirrups. The tensile resistance of such links and stirrups should not be less than the designed tension in the tie (see Figure 2.3);
- bars lapped within insitu topping concrete with projecting links or stirrups from the supporting precast units, such as beams or slabs (see Figure 2.4); or
- bars extended from the precast units connected by a method as given in clause 2.8.1.3.

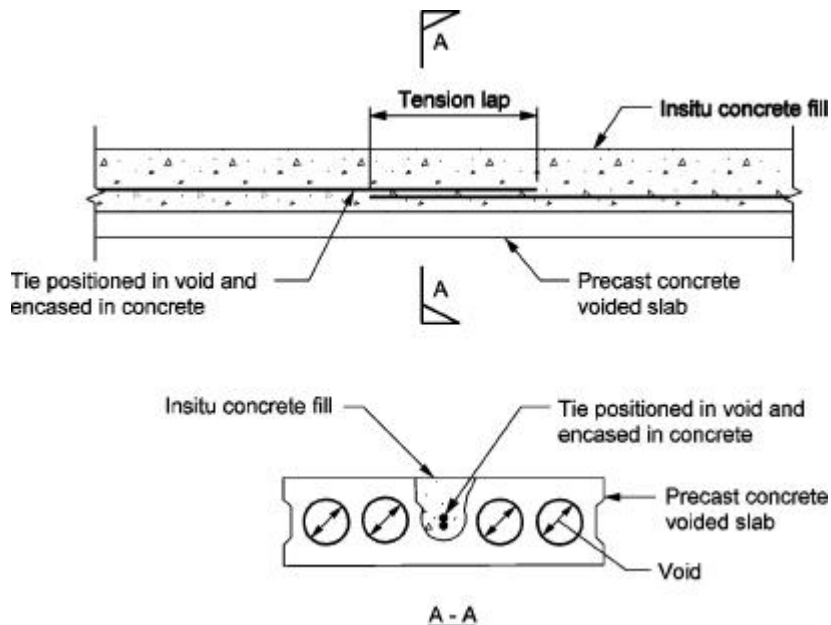
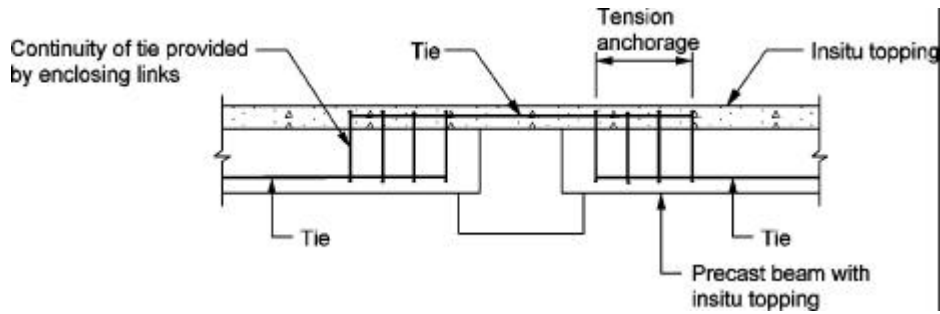
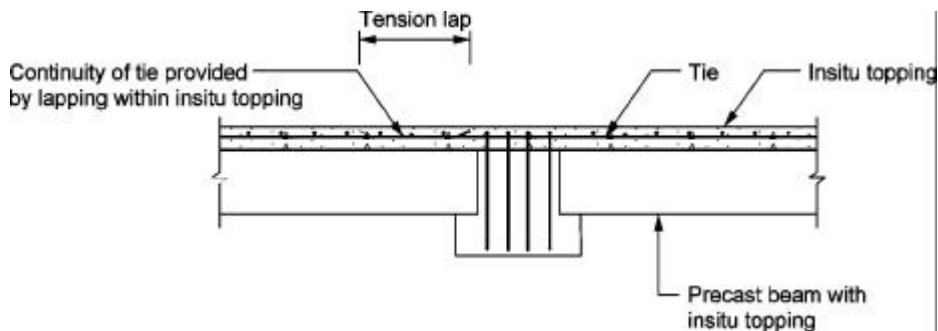

Figure 2.2 – Continuity of ties: bars in precast member lapped with bar in insitu concrete



**Figure 2.3 – Continuity of ties: anchorage by enclosing links**



**Figure 2.4 – Continuity of ties: bars lapped within insitu concrete**

#### 2.7.8.11 Anchorage in structures

All structures with five or more storeys, the precast floor or roof units should be effectively anchored if these units are not utilised to provide the ties in accordance with clauses 2.7.8.1 to 2.7.8.8. The anchorage should be capable of supporting the dead weight of the unit to that part of the structure which contains the ties.

#### 2.7.8.12 Eccentricity

Ties connecting precast floor or roof units should be so designed and placed as to minimise eccentricity.

#### 2.7.8.13 Anchorage at supports

In case reinforcing bars are used to provide the structural integrity of slab ends supported on corbels or nibs, great care must be taken to ensure it is adequately lapped and anchored (see clauses 2.7.8.9 and 2.7.8.10). Allowance should also be made for constructional inaccuracies (see clause 2.7.9.9).

### 2.7.9 Design of bearings

#### 2.7.9.1 General

The integrity of a bearing is preserved by three essential measures:

- an overlap of reinforcement in reinforced bearings;
- a restraint preventing loss of bearing due to movement; and
- an allowance for the cumulative effects resulting from production and erection tolerances (see clauses 3.12.2 and 3.16.5).

### 2.7.9.2 *Net bearing width of non-isolated members*

The net bearing width for a member should be taken as:

$$\text{Net bearing width} = \frac{\text{ultimate support reaction}}{\text{effective bearing length} \times \text{ultimate bearing stress}}$$

or 40 mm, whichever is greater.

(See clause 2.7.9.3 for determination of the effective bearing length and clause 2.7.9.4 for the design ultimate bearing stress.)

The net bearing width should be increased to cater for any free movement permitted or rotation of the bearing about the support.

### 2.7.9.3 *Effective bearing length*

The effective bearing length of a member is the lesser of:

- bearing length;
- one-half of bearing length plus 100 mm; or
- 600 mm.

### 2.7.9.4 *Design ultimate bearing stress*

The design ultimate bearing stress is based on the weaker of the two bearing surfaces and is calculated as follows:

- $0.4f_{cu}$  for dry bearing on the concrete;
- $0.6f_{cu}$  for bedded bearing on concrete; or
- $0.8f_{cu}$  for contact face of a steel bearing plate cast into a member or support, with each dimension not exceeding 40% of the corresponding concrete dimension.

An intermediate value of bearing stress between dry and bedded bearings may be used for flexible bedding.

### 2.7.9.5 *Net bearing width of isolated members*

The net bearing width for isolated members should be that of non-isolated members plus 20 mm.

### 2.7.9.6 *Detailing for simple bearing*

Over and above the net bearing width calculated in accordance with 2.7.9.2, allowances for spalling and constructional inaccuracies should be made in the nominal width selected (see Figure 2.5). The effects of accidental displacement of a supported member during erection should also be considered. The minimum anchorage lengths of reinforcement required by the Code of Practice for the Structural Use of Concrete should be provided.

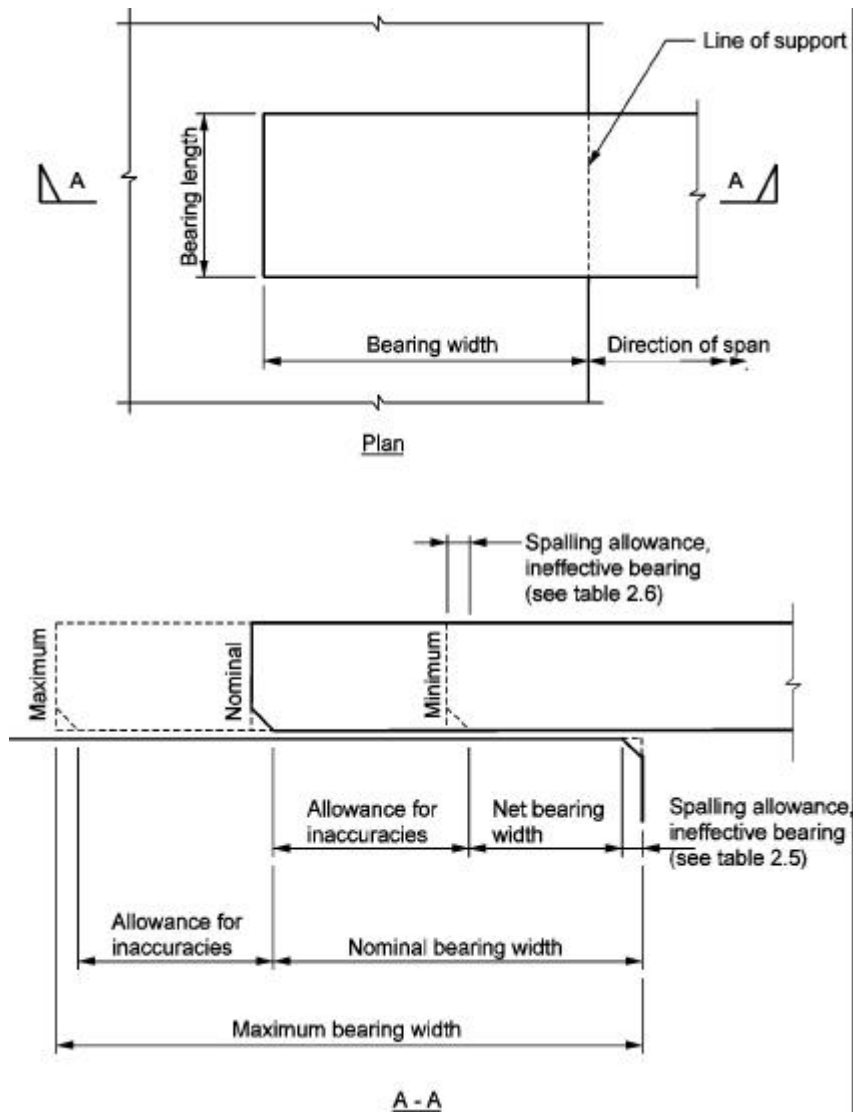

Figure 2.5 – Schematic arrangement of allowance for bearing

### 2.7.9.7 Allowances for spalling at supports

Recommendations for the allowances of ineffective portion of bearing area are given in Tables 2.5 and 2.6. When determining the outer edge of a support or the end of a supported member, chamfers occurring within the areas subjected to spalling may be discounted.

**Table 2.5 – Allowances for effects of spalling at supports**

Material of support	Distance assumed ineffective (mm) (measured from outer edge of support)
Steel	0
Concrete grade 30 or above, plain or reinforced (in general)	15
Concrete less than grade 30, plain or reinforced (in general)	25
Reinforced concrete with outer edge less than 300mm deep where vertical loop is not greater than 12mm diameter	Nominal end cover to reinforcement on outer face of support
Reinforced concrete with outer edge less than 300mm deep where vertical loop is 16mm diameter or above	Nominal cover plus inner radius of bend of bars
When particular constituent materials are used in concrete, adjustment to the distances assumed should be made.	

**Table 2.6 – Allowances for effects of spalling at supported members**

Reinforcement at bearing of supported member	Distance assumed ineffective (mm) (measured from end of supported member)
Straight bar, horizontal loops or vertical loops of 12 mm diameter or less	The greater of 10 mm or nominal end cover
Tendons or straight bars exposed at end of member	0
Vertical loops of 16 mm diameter or above	Nominal end cover plus inner radius of bend of bars

### 2.7.9.8 Steel shims

Steel shims should not be used at areas that are susceptible to spalling. It is essential that steel shims should be removed after grouting. When joint details are prepared, it should be demonstrated that all shims can be easily removed. Where steel shims cannot be removed, the effect of load transfer via the shims should be designed for.

### 2.7.9.9 Allowance for construction inaccuracies

The cumulative effect of construction inaccuracies and manufacturing tolerances should be allowed for. Recommendations for tolerances are given in clauses 3.12.2 and 3.16.5 for production and erection respectively.

The provision of clearances is recognised by the designer and the precaster of the need for interface tolerances. Clearance should provide a buffer area where combined erection and production variations can be absorbed, and the actual clearance provided should reflect all the specified tolerances. The minimum combined total tolerance allowed should be at least equal to the square root of the sum of the individual tolerances squared.

#### 2.7.9.10 *Bearings transmitting compressive forces*

Where a bearing is required to transmit vertical load from a wall which extends over the end of a supported member, a bedded bearing should be used.

#### 2.7.9.11 *Other forces at bearings*

##### (a) Horizontal forces at bearing

The horizontal forces at bearings may be induced by creep, shrinkage, temperature effects, misalignment, lack of plumb or other causes. When these forces are significant, the structural capacity of the supporting member may be impaired. Allowances should be made by the provision of:

- sliding bearings which allow longitudinal and lateral movement;
- additional lateral reinforcement at the top of the supporting member; or
- continuity reinforcement which ties the ends of the supported members together.

##### (b) Rotation at bearing

Suitable bearings should be used to accommodate the rotations at end supports in particular for flexural members. Allowances should be made for any consequential increases in bending moments or bearing stresses due to rotations.

#### 2.7.9.12 *Concrete corbel*

The design and reinforcement detailing of corbels should be in accordance with the Code of Practice for the Structural Use of Concrete.

## **2.8 JOINTS AND CONNECTIONS**

### **2.8.1 Structural connections**

#### *2.8.1.1 General*

The overall stability of a building and the temporary stability of individual members during construction should be checked. The recommendations of clause 2.3 should be followed. Handling and construction stresses should be considered. Creep effects for prestressed members should also be considered. If connection failure could result in a catastrophic failure of the structure, these connections should be avoided and the engineer should use a detail appropriate to the circumstance.

Requirements for anchorage and continuity of ties at connections are given in clauses 2.7.8.9 and 2.7.8.10. Account should be taken of the effects on connections of movements and whether or not these need to be specifically catered for.

The recommendations for water tightness for joints are given in clause 2.8.2.

A free flowing, self-compacting and non-shrink grout should be used at the interface with the precast elements to minimise the risk of cracking and to ensure good compaction at the joint.

For some precast elements such as semi-precast balconies or lost forms, the preparation and specification of the construction joints should be carefully monitored and specified to ensure that the design is adequate and the intent and details are reflected in the construction details.

The fire resistance and durability requirements for joints should be at least similar to the members being connected.

#### *2.8.1.2 Design*

The design of connections should follow those design methods and considerations for reinforced concrete, prestressed concrete and structural steel. Otherwise, the connection design should be based on tests.

#### *2.8.1.3 Detailing of reinforcement*

##### (a) General

The design of connections should take into account those assumptions made in the analysis of the overall structure as well as those elements at critical sections.

- (b) Lapping of bars  
Where bars passing through the connection are lapped to provide continuity of reinforcement, the recommendations of the Code of Practice for the Structural Use of Concrete and clause 2.7.8.10 of this code apply.
- (c) Reinforcement grouted into aperture  
An adequate capacity should be provided for grouted reinforcing bars to prevent pullout.
- (d) Reinforcement loops  
Where dowel bars pass through overlapping loops of reinforcement, which project from each supported member, to provide continuity over a support the bearing stress of the loops should be in accordance with the Code of Practice for the Structural Use of Concrete.
- (e) Couplers  
Reinforcement may be connected by couplers. The concrete cover to the couplers should not be less than that specified for reinforcement.  
  
A locking device should be used for threaded coupler connections where there is a risk of the threaded connection working loose, e.g. during vibration of insitu concrete. Reference should be made to the relevant Standards and the manufacturers' technical specifications for guidance and acceptance criteria for the usage and testing of couplers.
- (f) Welding of bars  
When bars are connected by welding, the connection should be designed to accommodate the forces applied. Reference should be made to the relevant Standards and the manufacturers technical specifications for guidance and acceptance criteria for the work and testing of welding bars.
- (g) Sleeving  
Either of the following types of sleeve may be used for jointing, provided the strength and deformation of the joint have been determined by test:
- grouted, resin-filled or swaged sleeve capable of transmitting both tensile and compressive forces; or
  - sleeves that mechanically align the square-sawn ends of two bars to allow the transmission of compressive forces only.
- The maximum bar size used for the sleeved connection should be carefully considered taking into account the necessary force transmission and anti-bursting considerations as well as practical considerations to avoid congestion with other reinforcement bars in the precast elements. The design, manufacture and method of assembly of the sleeved joint should ensure the accurate alignment of the ends of the two bars into the sleeve. The sleeve should be provided with concrete cover not less than that specified for normal reinforcing bars.

#### 2.8.1.4 *Compression joints*

The joint should be designed to resist the forces and moments derived from the analysis of the structure. In normal circumstances, the area of concrete to be utilised for calculating the strength of the joint in a wall or column should be the greater of:

- 75% of the area of contact between the wall or column and joint; or
- the area of the insitu concrete excluding the part of any intruding slab or beam units  
However those parts of the floor slab or beam units that are solid over the bearing may be included in calculating the strength and such units should be properly bedded on concrete or mortar of adequate quality. This area should not be taken as greater than 90% of the wall or column area.

#### 2.8.1.5 *Shear joints*

A shear joint may be assumed effective if the joint is grouted with a suitable concrete or mortar mix of adequate strength and one of the following conditions is satisfied:

- (a) Units transmitting in-plane shear  
The units should be restrained from moving apart. Provided the design ultimate shear stress in the joint does not exceed  $0.23 \text{ N/mm}^2$ , reinforcement need not be provided in or across the

joint, and the sides of the units forming the joint may have a normal finish. Smooth moulded finishes should be roughened.

(b) Joints under compression

Provided the design ultimate shear stress does not exceed 0.45 N/mm<sup>2</sup> and the sides or ends of the panels or units forming the joint have a rough as-cast finish, reinforcement will not be required.

(c) Shear stress less than 1.3 N/mm<sup>2</sup>

Where the shear stress due to ultimate loads, calculated on the minimum root area of a castellated joint, is less than 1.3 N/mm<sup>2</sup>, separation of the units normal to the joints should be prevented under all loading conditions by either steel ties across the ends of the joint or by the compressive force normal to the joint. The projecting keys of a castellated joint are usually tapered to ease the removal of formwork. However, the taper should not be excessive in order to limit any movements in the joint.

(d) Shear reinforcement provided

The entire shear force  $V$  due to design ultimate loads should not exceed:

$$V = 0.6 F_b \tan \alpha_f$$

where;

$F_b$  is  $0.87 f_y A_s$ ; or the anchorage value of the reinforcement, whichever is the lesser,

$A_s$  is the minimum area of reinforcement,

$\alpha_f$  is the angle of internal friction between the faces of the joint.

Note:  $\tan \alpha_f$  can vary between 0.7 and 1.7 and is best determined by tests. However, for concrete-to-concrete connections, the values used may be taken from Table 2.7.

**Table 2.7 – Values of  $\tan \alpha_f$  for concrete connections**

Type of surface	$\tan \alpha_f$
Smooth interface, as in untreated concrete	0.7
Roughened or castellated joint without continuous insitu strips across the ends of joints	1.4
Roughened or castellated joint with continuous insitu strips across the ends of joints	1.7

2.8.1.6 *Examples of joints*

Examples of typical joints are shown in Figures 2.6 to 2.19. These connections are included for illustrative purposes only. They are not mandatory and alternative connection details may be used. In all instances, the design should demonstrate that the connections are able to resist the applied structural actions. Where appropriate, the suitability of the joint to act as a pinned or moment connection is highlighted.

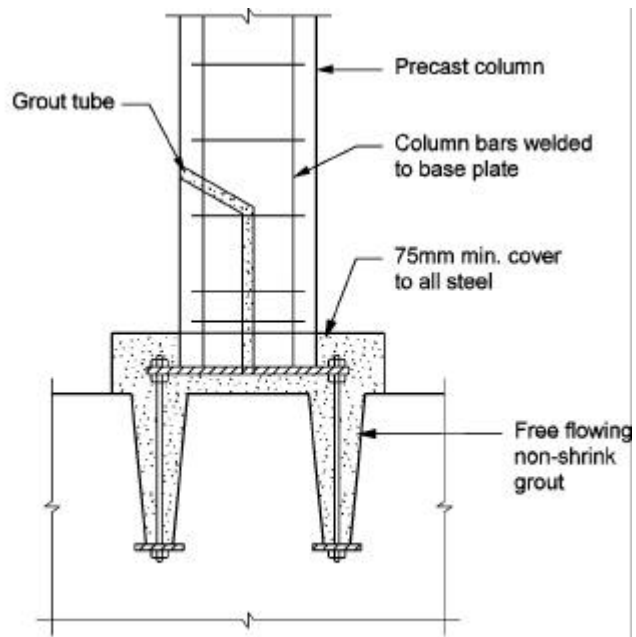

Note: Can be designed as either pinned or moment connection

Figure 2.6 – Column base plate with base larger than column

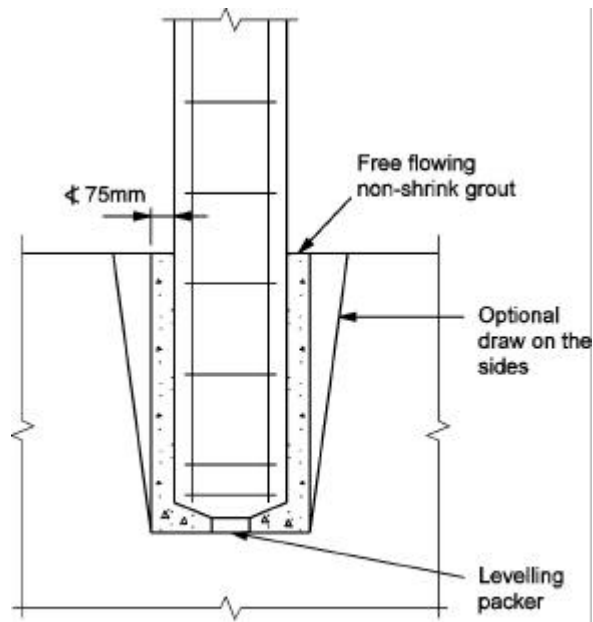

Note: Can be designed as moment connection

Figure 2.7 – Column base cast into socket

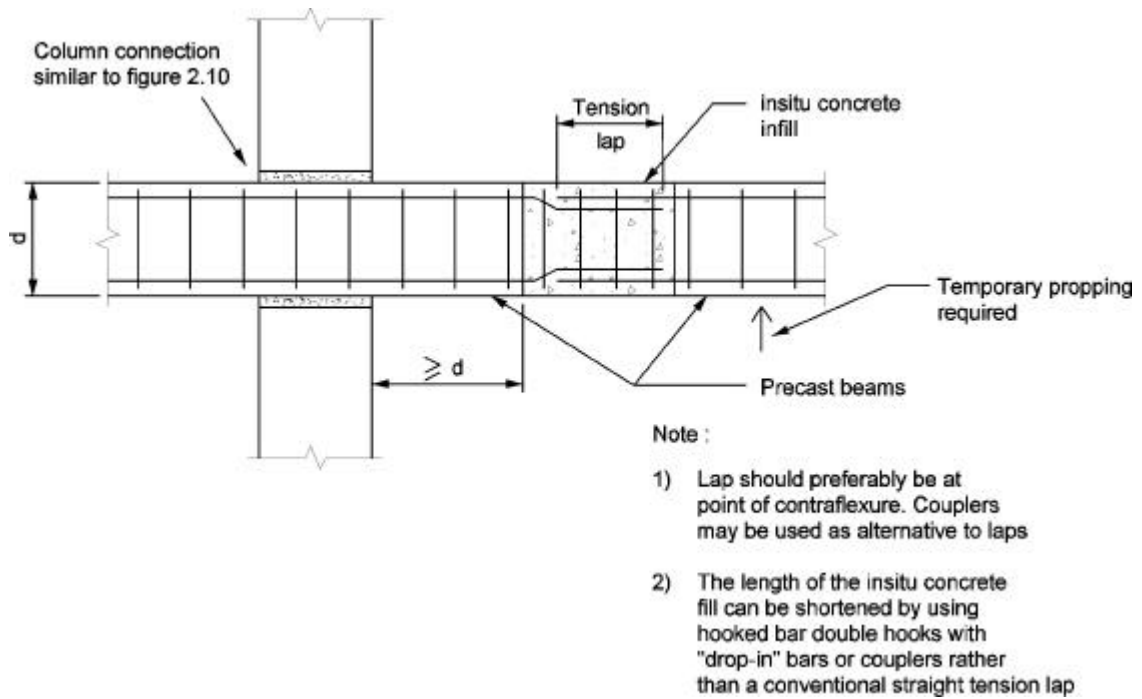

Figure 2.8 – Beam to beam connection with moment continuity

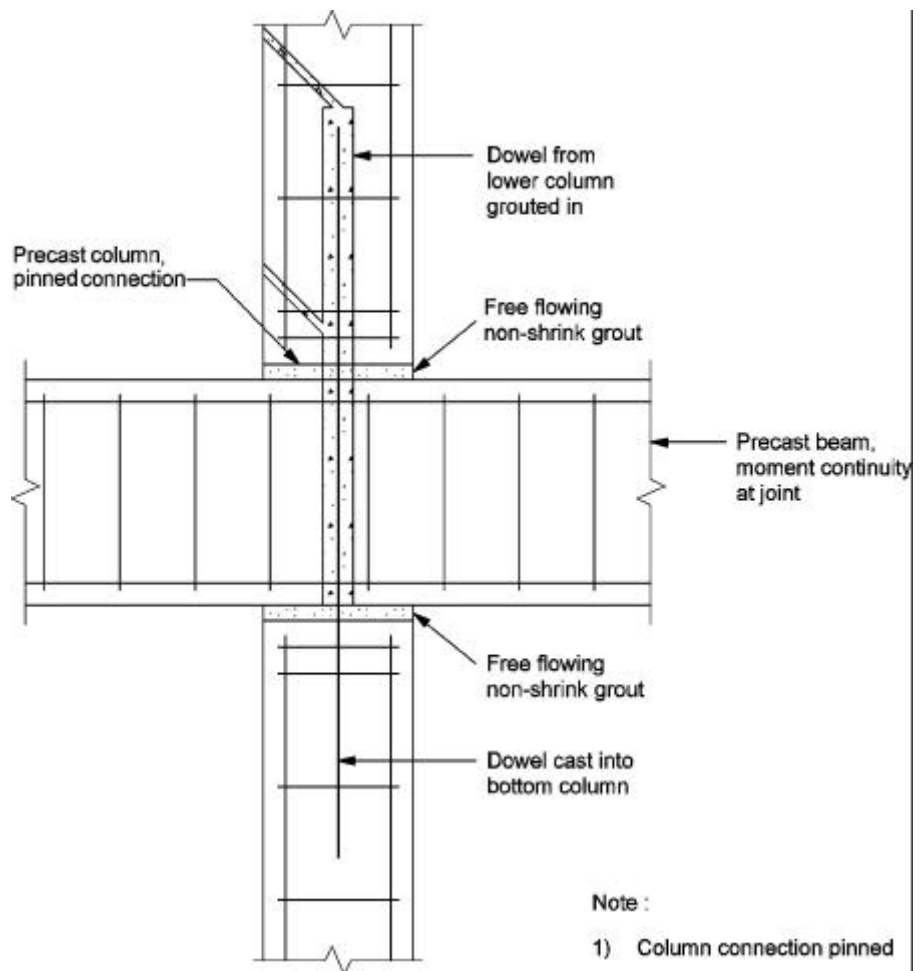

Figure 2.9 – Column to column joint with beam passing across

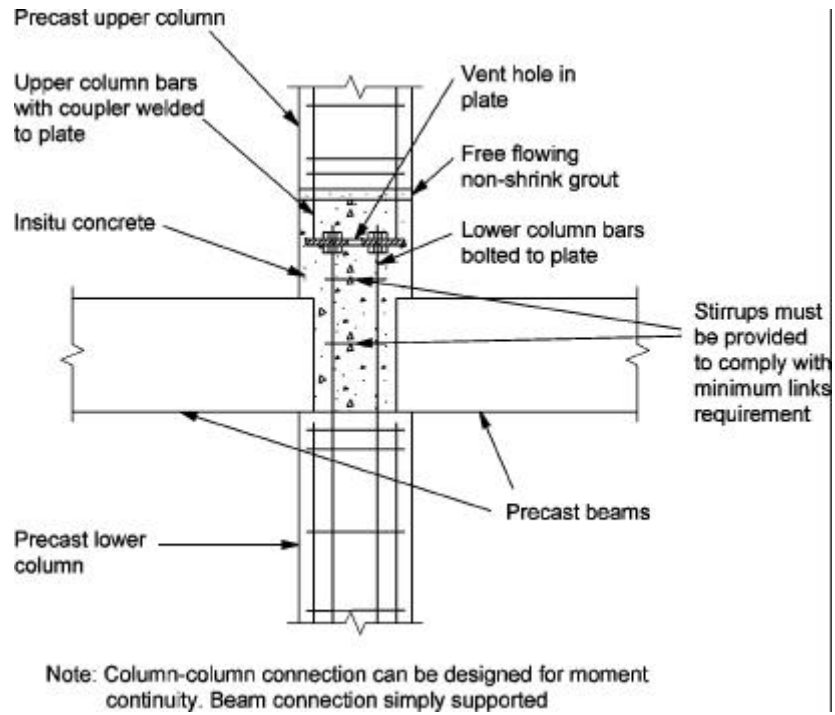

Figure 2.10 – Column to column connection with beams framing into side

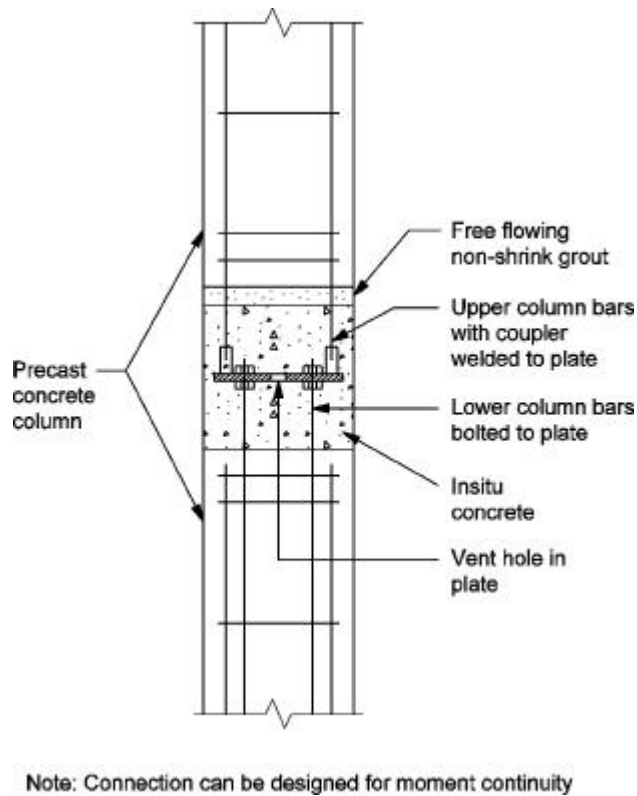
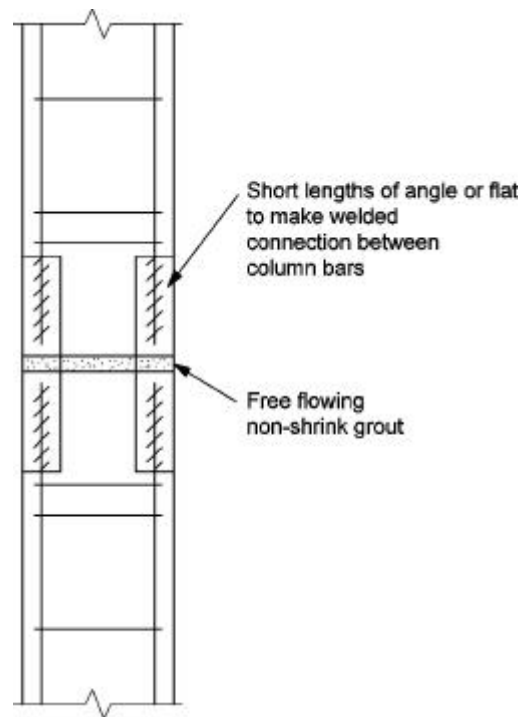
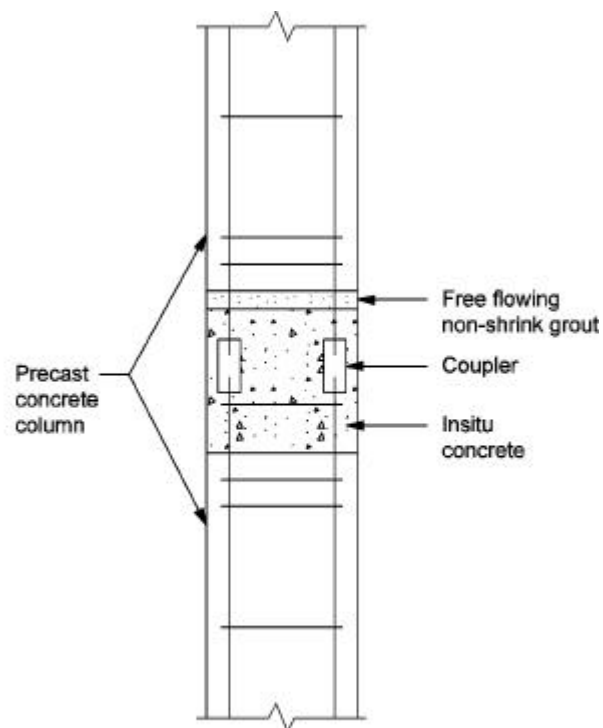

Figure 2.11 – Column splice using combined welded and bolted connection



**Figure 2.12 – Column splice using welded connection**



Note: Connection can be designed for moment continuity

**Figure 2.13 – Column splice using couplers**

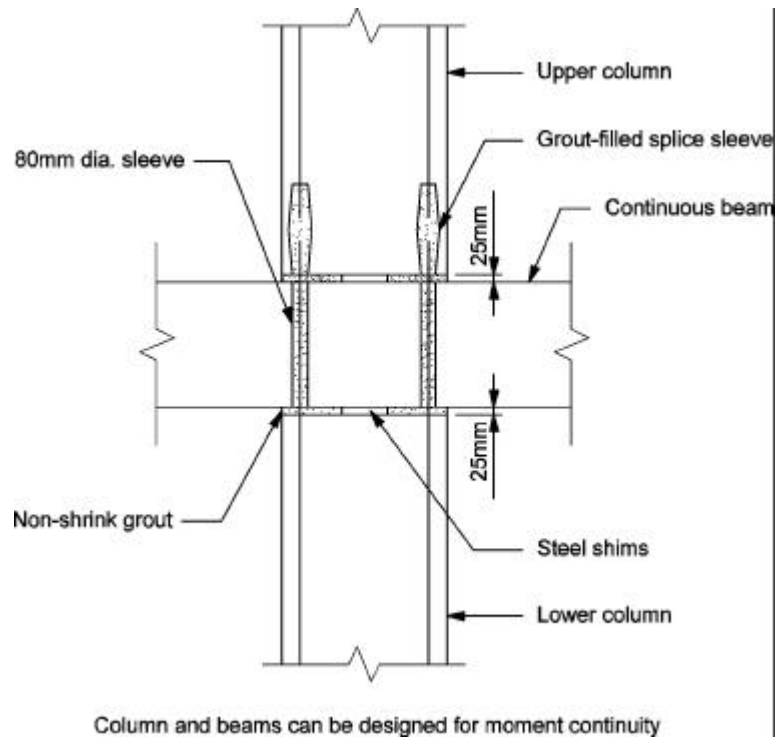

Figure 2.14 – Column splice using grout filled tube

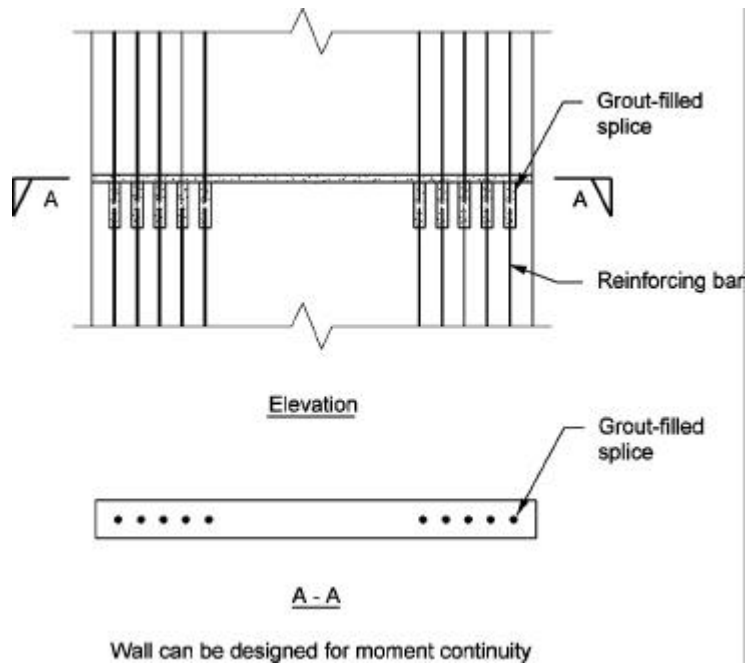

Figure 2.15 – Wall splice using grout filled tube

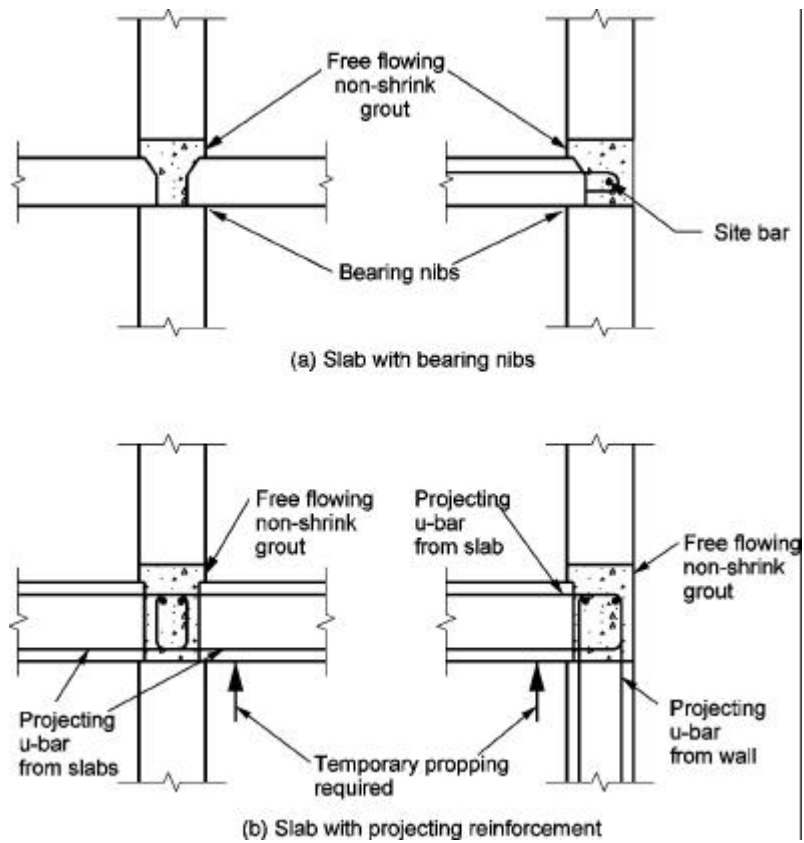

Figure 2.16 – Horizontal wall joints supporting floor slabs

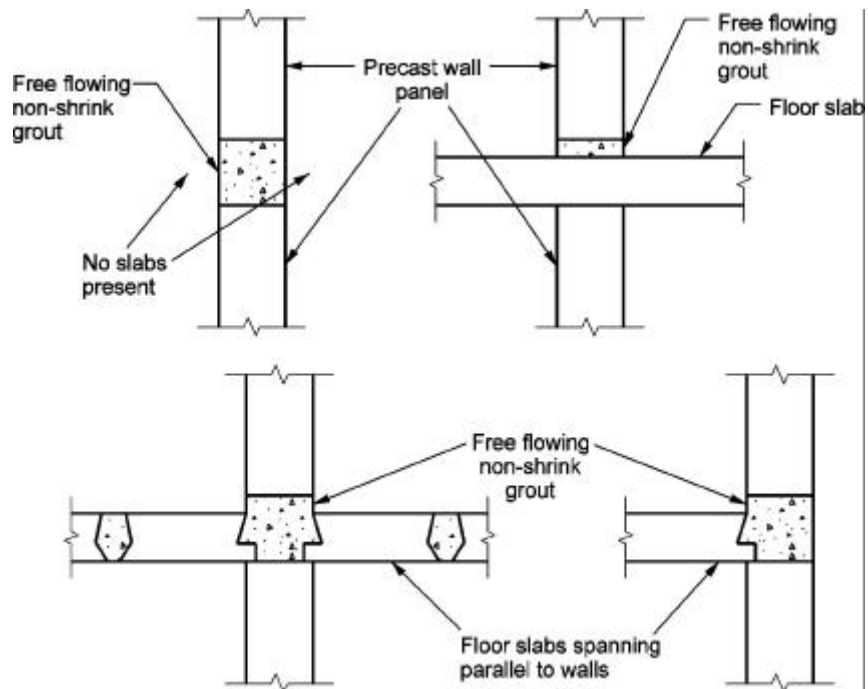

Figure 2.17 – Horizontal wall joints not supporting floor slabs

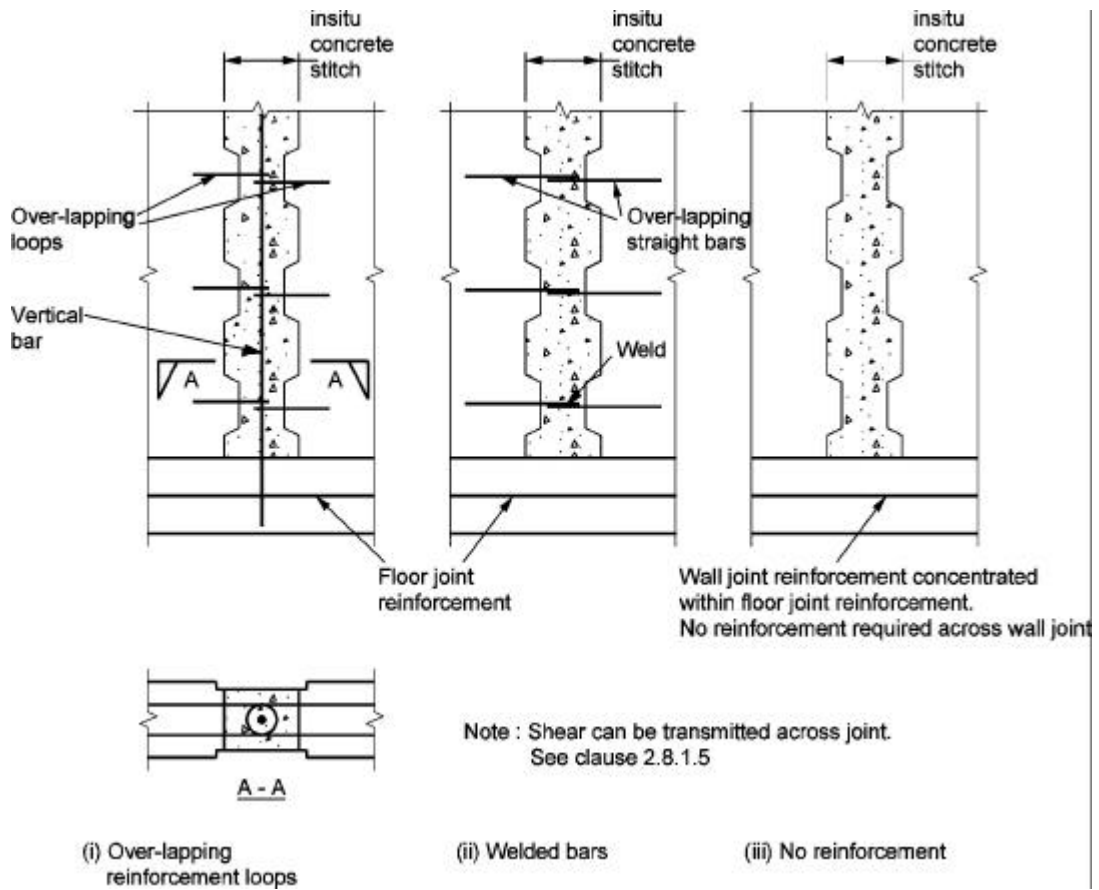

Figure 2.18 – Elevation of vertical wall joints

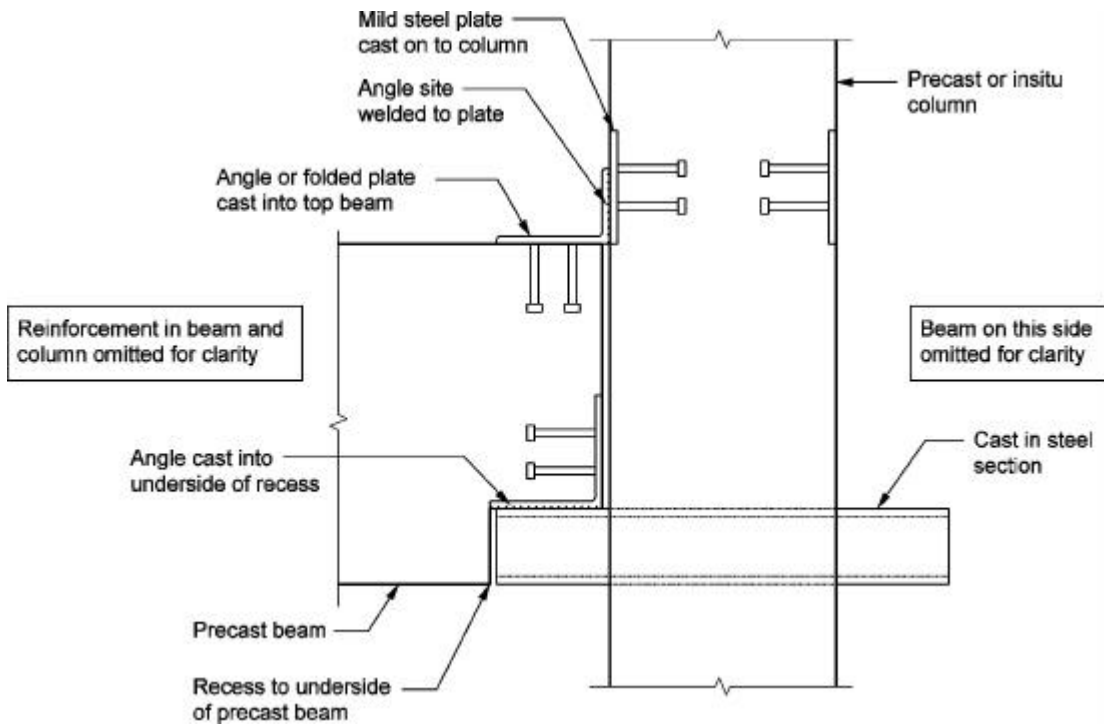

Figure 2.19 – Beam and column connection using embedded steel members

## 2.8.2 Water tightness of joints

### 2.8.2.1 Scope

This section deals with the detailing of joints between external precast panels ensuring that the joints are watertight against the wind and rain. Guidance is given on the properties and uses of various jointing materials, and examples of typical joints are illustrated.

The performance of a specific joint is critically influenced by the exposure conditions, the joint movements and the properties of the specific jointing materials used. The typical details given in this code are provided for general guidance. For optimum performance and maximum life, specific advice should always be sought from the manufacturers of the materials used.

### 2.8.2.2 Materials for jointing

A classification of sealants, sealing strips, gaskets and baffles is given in Table 2.8.

**Table 2.8 – Classification of sealants, sealing strips, gaskets and baffles**

Seal type	Chemical type	Physical type	Movement accommodation (see note 1)	Life expectancy (years) (see note 2)
Gun-applied, non-curing sealants	butyl	plastic	low	up to 10 (not exposed)
	acrylic	plastoelastic	low-medium	up to 15
Gun-applied, one-part chemically-curing sealants	polysulfide	elastoplastic	medium-high	up to 25
	polyurethane	elastic	medium-high	up to 20
	silicone	elastic	medium-high	up to 25
Gun-applied, two-part chemically-curing sealants	polysulfide	elastoplastic	medium-high	up to 25
	polyurethane	elastic	medium-high	up to 20
	silicone	elastic	low-high	up to 25
Sealing strip (mastic)	butyl	plastic	low	up to 15
	polyisobutylene/ butyl	elastoplastic	low	up to 15
Sealing strip (cellular)	PVC polyethylene polyurethane butyl neoprene EVA	range in properties from plastic to elastic	low-high	up to 20
Gaskets	neoprene natural rubber EPDM butyl rubber polyurethane silicone EVA	elastic	low-high	up to 20
Baffles	neoprene PVC polyethylene aluminium stainless steel zinc copper	profiles loosely fitted with adjoining components	low-high	up to 40
Notes:				
1. The movement that a sealant is capable of tolerating throughout its working life. Expressed as a percentage of the joint width, Low ≈ 5%, Medium ≈ 15%, High ≈ 25%				
2. The actual service life of a sealant is dependent not only on composition but also on environmental conditions and quality of application				

### 2.8.2.3 Sealants for joints

#### (a) General

In choosing the appropriate type of sealant for the joints, consideration should be made in respect of the movements between the components to be joined, the bond that is achievable between the components and the sealant, and the nature of the sealing material itself.

Sealants are classified as elastic, elastoplastic, plastoelastic or plastic according to their response to movement.

#### (b) Joint width

Joint widths should be sized to accommodate construction tolerances, and the accommodation of movements without overstressing the jointing material. Irrespective of movement, a joint width of 5 mm is the minimum practicable for sealant application.

#### (c) Joint preparation

Satisfactory performance is critically dependent on the satisfactory adhesion of the sealant to the joint surfaces. Primers may be recommended by the manufacturer for some materials. Formwork oils, curing compounds, silicone waterproofing admixtures and surface coating materials may reduce bond and require special precautions.

Water jetting, sand blasting, wire brushing or the use of retarder may be required to prepare the concrete joint surfaces in certain instances.

Consideration should be given to the use of chamfers to reduce edge damage.

### 2.8.2.4 Back up material and bond breaker

To ensure good adhesion, a firm backing should be provided for the application of sealants. The required shape and proportions of the sealant are achieved by the correct installation of the back up material.

Sealants in movement joints should not adhere to the backing material to avoid any unnecessary restraint.

To ensure that the sealant and back up materials, bond breakers and joints fillers are compatible and appropriate for the proposed end use, advice from the manufacturer should be obtained as necessary.

The sealant backing may be provided by a closed cell foam back up material alone (see figure 2.20a), a thin self adhesive bond breaker tape (see figure 2.20b) or a joint filler separated from the sealant by a thin self adhesive bond breaking tape (see figure 2.20c).

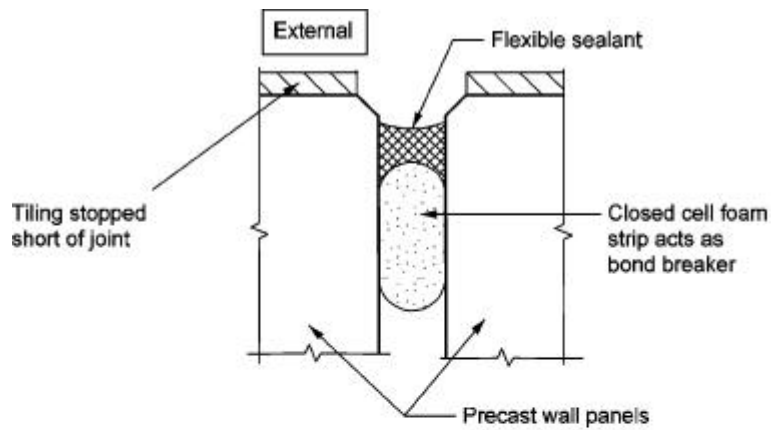

2.20 (a) Back up strip also acts as bond breaker. Edge chamfer keeps tiling clear of sealant and protects corner of unit/side of joint from damage

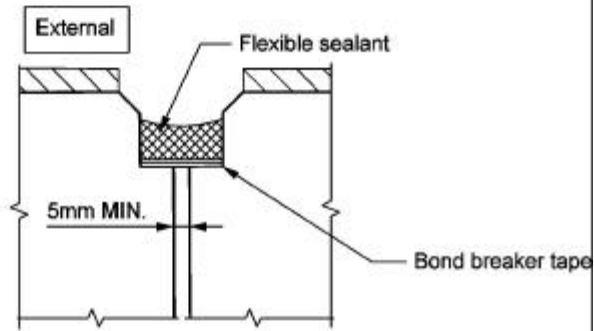

2.20 (b) Face of joint opened up to give adequate sealant width. Tape bridges narrow joint

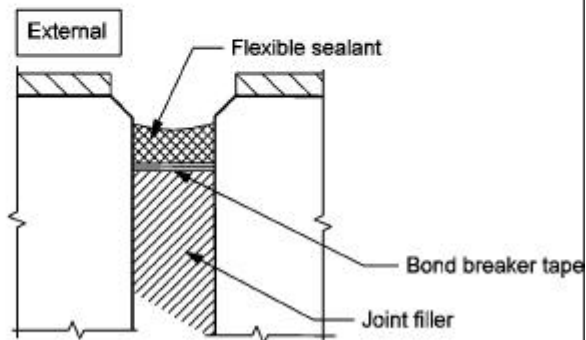

2.20 (c) Bond breaker tape separates joint filler from sealant

Figure 2.20 – Back-up materials and bond breakers in movement joints

- (a) Minimum joint gap widths
 

The minimum joint gap width should be derived to accommodate the construction and manufacturing tolerances, the range of movements anticipated, the required dimensions of the sealant to accommodate those movements, and the desired appearance.

A minimum joint width of 12 mm between panels is a common practice. However, for structural movement joints, a joint width of 50 mm or more may be required. Joints of such width require special sealant properties to avoid slump.

For elastic sealants, the minimum thickness should be 5 mm, the ratio of width to thickness should never exceed 1:1 and for optimum performance 2:1.
- (b) Sealant application
 

High moisture content may be detrimental to the adhesion of the sealant. Sealing should not be undertaken if there is free water present on the surface of the concrete.
- (c) Types of movement
  - (i) General
 

The magnitude of the movement, and also the mode, frequency and rate of movement affect the performance of a sealed joint.
  - (ii) Choice of sealant
 

There are many factors affecting the choice of sealant suitable for the different types of movement. However, as a general rule, joints which have to accommodate frequent and rapid movement need an elastic sealant, while joints in massive components, with high thermal inertia resulting in much slower movement, may be satisfactorily sealed with an elastoplastic, plastoelastic or a plastic sealant.
  - (iii) Types and causes of failure of sealants
 

The different ways in which sealants can fail as a consequence of different factors including climatic conditions, environmental factors, substrate incompatibility, abrasion and traffic loading need to be considered when selecting a sealant.

#### 2.8.2.5 Gaskets

- (a) General
 

Gaskets are used to provide a barrier against wind and rain. They are required to be under compression at all times for proper functioning.
- (b) Materials
 

Gaskets made of natural rubber compounds have to be protected from the weather by a synthetic rubber skin. For special properties, such as resistance to oils, synthetic rubbers and plastic materials have to be specifically formulated for the intended use. Gaskets can be various profiles of solid or hollow section formed from cellular or non-cellular material or combinations of these sections or materials. Variations in the mechanical properties of cellular gaskets are achieved by variations in density, material hardness and cell size and whether or not cells are interconnecting.

Cellular materials have a relatively shorter service life in general unless they are protected from UV degradation by an outer skin of non-cellular material.

Cellular material is available in sheets with or without adhesive and backing paper, and can be cut to provide simple relatively inexpensive gaskets.

Open cell materials are available impregnated with waxes or bituminous compounds, and may also be adhesive coated.
- (c) Design
  - (i) General
 

The selection of components and their edge profiles, the method and sequence of installation and the type of gasket are inter-related. It is always advisable to consult manufacturers at an early stage in the joint design. When designing gasket sealed joints, the recommendations of clause 2.8.2.5(c) (ii to vii) should be considered.

(ii) Primary and secondary seals

Gasket joints should be designed to provide primary and secondary points of gasket contact having an air space between them (see figure 2.21(b) and 2.21(c)).

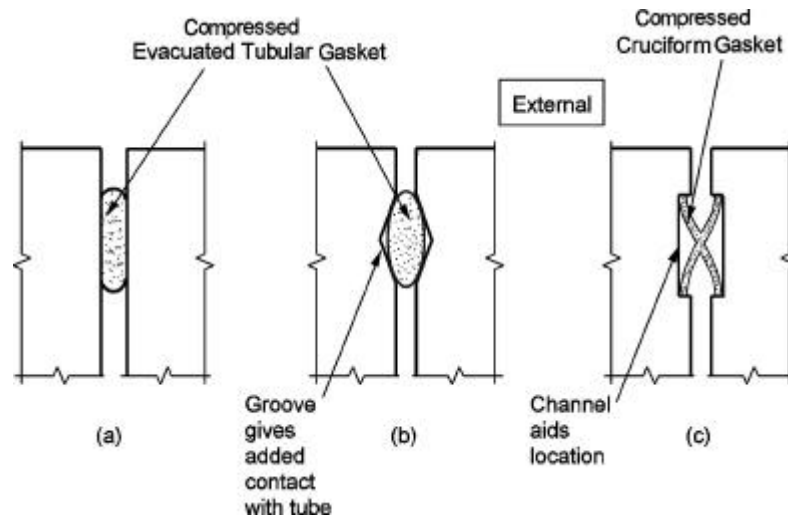

Figure 2.21 – Typical examples of gaskets in joints

(iii) Continuity at junctions between horizontal and vertical gaskets

For gaskets to be effective, continuity of seal should be provided at the junctions between the horizontal and vertical gaskets. These complex junctions are best produced as factory made joints incorporated as part of a gasket grid, so that site joining is limited to simple butt joints (see figure 2.22a).

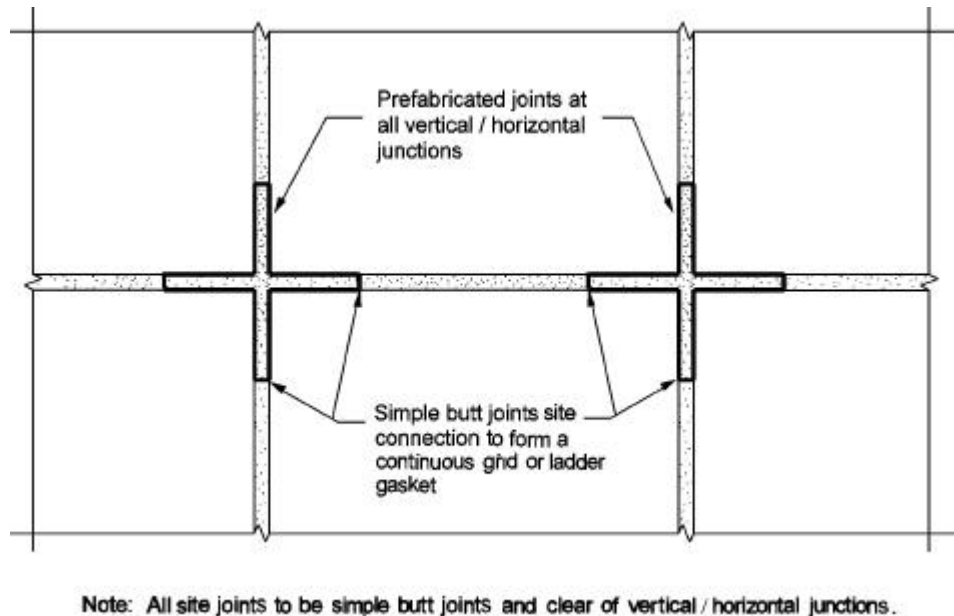
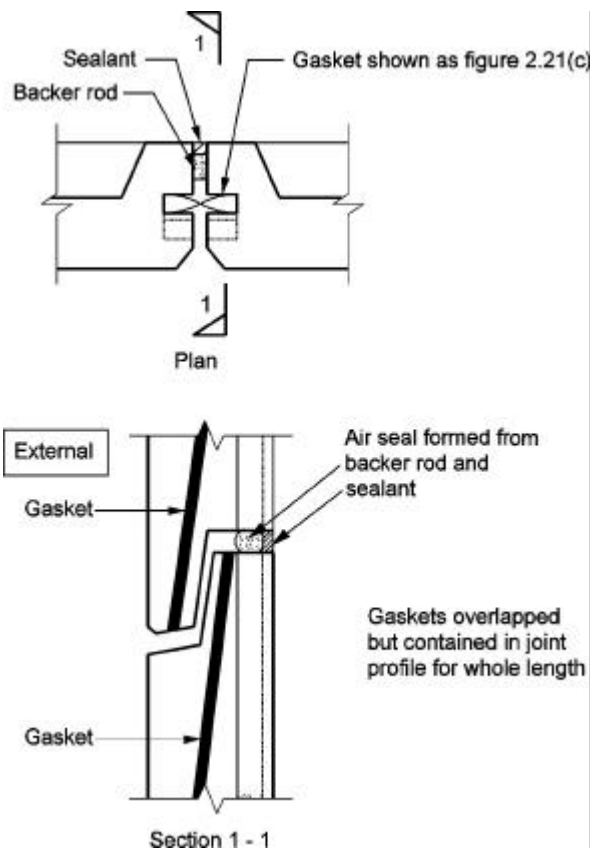

Figure 2.22 (a) – Gasket junctions: Continuous grid or ladder gasket

Gaskets connected by butt joints should only be used where good protection and effective continuity are provided at the joint. Where continuity cannot be achieved, especially at junctions in vertical joints, it is necessary that effective drainage, weather protection and adequate gasket overlaps are provided (see figure 2.22b).



**Figure 2.22 (b) – Gasket junctions: Non-continuous gasket**

(iv) Movement joints

When used in movement joints, gaskets should be deformed sufficiently to maintain compression over the entire movement range, yet not be so highly compressed as to incur significant compression set. For example, a cellular neoprene gasket should not be compressed in service more than 50% of its uncompressed thickness.

Gasket seals in movement joints can be fully effective from the completion of the installation.

(v) Installation

Care is needed in handling gaskets to avoid deformation or damage. Although the preparation of surfaces is not as critical as for sealants, it is essential that all surfaces should be clean, sound and free from gross imperfections. To ease the insertion of gaskets into a joint, lubricants recommended by the manufacturer may be used. Where possible, gaskets should not be stretched during installation. However, if this is unavoidable, sufficient time for the gaskets should be given for the gaskets to recover before trimming.

(vi) Force

The force necessary to compress a length of gasket in a joint can be considerable, particularly when the joint is assembled in the sequence component/gasket/ component. As a result, gaskets when correctly installed may exert force, such force should be taken into account in the course of design.

(vii) Durability

The useful life of gasket materials has to be considered at the design stage. In movement and other important joints, gasket life may be less than the building life. The conditions of use, qualities of materials etc. determine the actual life of the gasket. It may be necessary to specify that seals may need major attention or replacement during the life of the structure.

2.8.2.6 Sealing strips

(a) General

Preformed sealing strips are available in a range of sizes and sections. There are two basic types:

- mastic strips; and
- impregnated or coated cellular strips.

(b) Mastic strips

These are normally installed during the assembly of components. They require an initial compression to ensure proper adhesion to the components forming the joint. As a degree of compression is also required during in service, mastic strips are unsuitable for joints which open beyond their assembled size.

(c) Impregnated or coated cellular strips

These may be supplied in a precompressed form, and one face may be adhesive coated. When precompressed, they can readily be installed within the joint gaps, but should be of a suitable size to be maintained under the degree of compression specified by the manufacturer throughout the range of joint movements. The degree of compression may be varied according to the level of sealing performance required.

To ensure uniformity of compression and stability of the seal, it is important that the joint faces are parallel. Seal stability is also influenced by the installed depth to width ratio of the seal, which should not exceed 1:1 in service. At installation a ratio of 2:1 should be achieved. Sufficient joint depth must be provided to accommodate the seal with these depth to width ratios.

For external applications, sealing strips should have adequate exposure resistance for the proposed service conditions.

2.8.2.7 Joint fillers

(a) General

Fillers for movement joints should be carefully selected to suit their intended use. To ensure that the sealant and filler are compatible, advice from the manufacturer should be sought.

Expanded polystyrene is not a suitable material for a joint filler.

The range of properties of typical cellular plastics and rubber fillers is given in Table 2.9.

**Table 2.9 – Fillers for movement joints**

Material	Application	Form	Density range (kg/m <sup>3</sup> )	Range of pressures for 50% compression (N/mm <sup>2</sup> )	Range of recovery after compression (%)	Tolerance to water immersion
Cellular plastics and rubbers	filler for movement joints	sheet or strip	40 to 60	0.07 to 0.34	85 to 95	suitable for infrequent immersion

(b) Functions

Joint fillers have the following functions:

- form part of the initial joint;
- during construction provide a barrier to dirt or debris, which could prevent joint closure;
- control the depth of sealant in the joint; and
- support the sealant.

(c) Properties

Joint fillers require the following properties:

- should be compressible;
- should not be extruded from the joint;
- should have resilience;
- should be non staining;
- should not contain cellulose to prevent termite investment;
- should have resistance to damage in handling; and
- should not present a fire hazard.

### 2.8.2.8 Baffles

Materials for baffles are listed in Table 2.8.

Baffles are installed loosely in multi-stage joints of cladding panels (see 2.8.2.9 (d)) to prevent the ingress of water. To be effective, they have to be adequately secured in position. Metal baffles are prone to rattle in the wind. Copper may cause staining and is not recommended in situations where this would be detrimental.

### 2.8.2.9 Joints of external walls

(a) General

The volume of water running down the face of a building in driving rain is greatly in excess of the rain falling on the joint surface. Where possible, the surface of the panel should be configured to direct this runoff away from the joints. Horizontal panel joint surfaces should always be sloped to shed water to the outside of the building.

Joint components must be accessible for inspection, repair and maintenance.

Installation of joint components may be obstructed by perimeter columns, walls or other elements. It is essential that the joint can accommodate these constraints, and achieve satisfactory connections between the seals of the vertical and horizontal joints. Levelling devices such as packers must be located in such a way that they do not affect the performance of the horizontal seals. Proper grout checks must be made at precast/in situ joints to prevent grout entering the joint surfaces and blocking drainage paths and affecting seals or baffles.

(b) Basic forms of joints

Two basic forms of joint for preventing the penetration of air and water through external precast concrete walls are illustrated:

- single stage sealing of joints; and
- two-stage sealing of joints.

(c) Single stage sealing of joints of external walls (see figures 2.23 and 2.24)

Sealing for both air and water penetration is provided by a sealant, generally applied at the face of the joint. This sealant provides the sole barrier; any failure will result in leakage.

Satisfactory performance depends on the durability of the jointing product, and the workmanship during installation.

If movements have to be accommodated, the demands on product performance are particularly great.

Sealant will normally have to be replaced during the life of the building.

Access is usually easy for inspection and repair, and does not cause disruption to occupants.

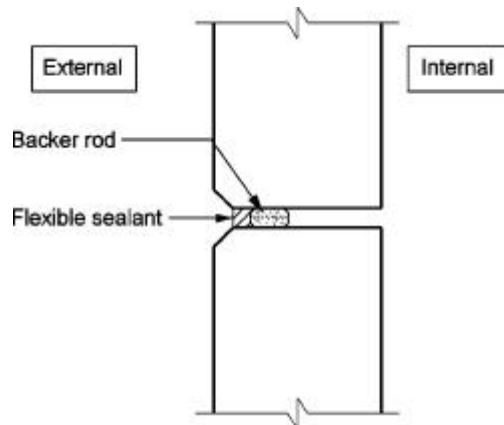

**Figure 2.23 – Single stage horizontal joint between precast wall panels**

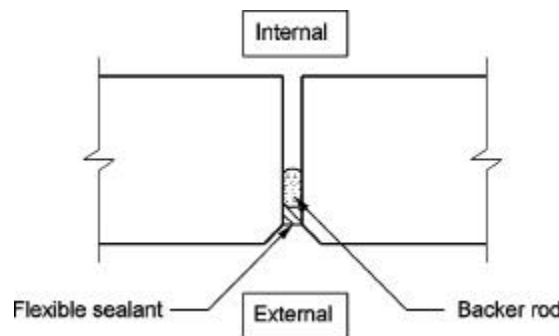

**Figure 2.24 – Single stage vertical joint between precast wall panels**

(d) Two-stage sealing of joints of external walls (see figures 2.25 to 2.27)

Sealing for air and water penetration is affected by two different mechanisms.

The main advantage of a two stage joint is that it has the potential of being more trouble free and durable, owing to the protection afforded to the jointing products.

To exploit this advantage, water should be excluded by designing a joint profile that prevents it from reaching the air seal at the inner edge of the joint.

The effectiveness of the air seal, by allowing air pressure to rise at the back of the joint, is the most important factor in preventing rain penetration through the joint.

Replacement of components must be considered in the design of the joints. Replacement, if needed, is more disruptive than for the single stage joint, normally requiring access to the building interior.

(i) Vertical joints

Figure 2.25 shows two types of two-stage vertical joints.

The wall panel must have sufficient width to accommodate the joint geometry. The minimum depth of joint from the external face of the walling to the face of the air seal should be 100 mm. There should be a space between the baffle and the air seal. Recessing of the baffle from the external face helps to reduce vulnerability to vandalism and exposure.

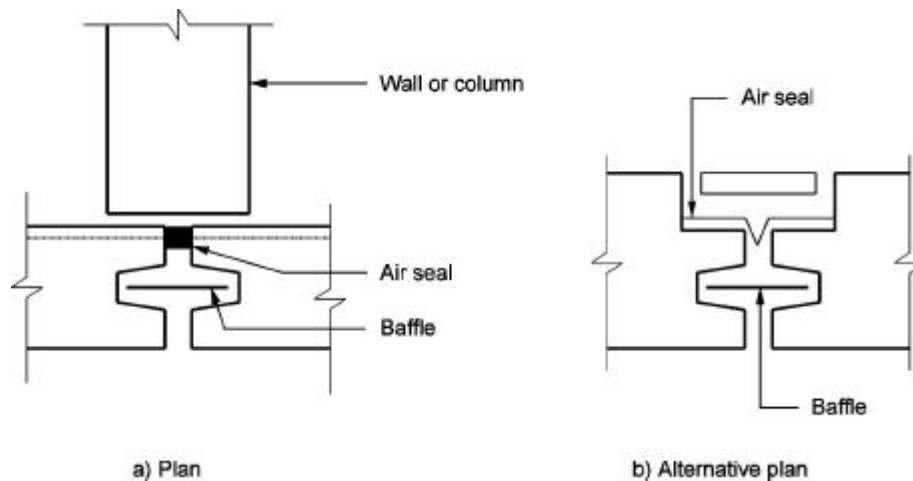

**Figure 2.25 – Two-stage vertical joints**

(ii) Horizontal joints

Figure 2.26 shows a section through a horizontal joint. The resistance to water penetration is provided by the upstand profile and the air seal at the inner edge.

For general construction, the recommended height of the overlap is 75 to 100 mm for exposed situations.

At the vertical joint intersection the overlap is provided by the baffle. It is important that the baffle extends beyond the groove and is not inadvertently left short.

Depending on fixing design, horizontal joints may also incorporate devices or packings to transfer loads. Profiles of horizontal joints may also incorporate handling fixings. Such fixings or devices need to be designed so that the functional needs for sealing are not affected by them.

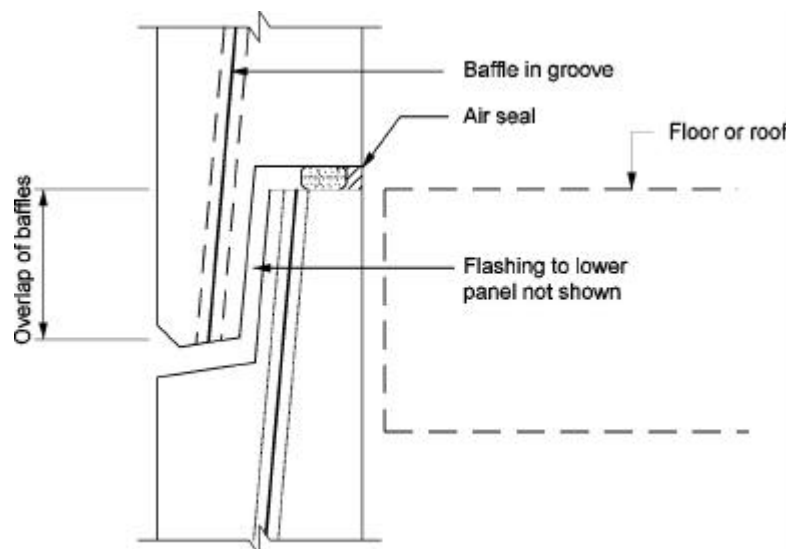

**Figure 2.26 – Baffle overlap in a two-stage horizontal joint**

Figure 2.27 shows methods for securing the suspended loose baffle at the joint intersections. If necessary, the baffle shown can be removed and replaced.

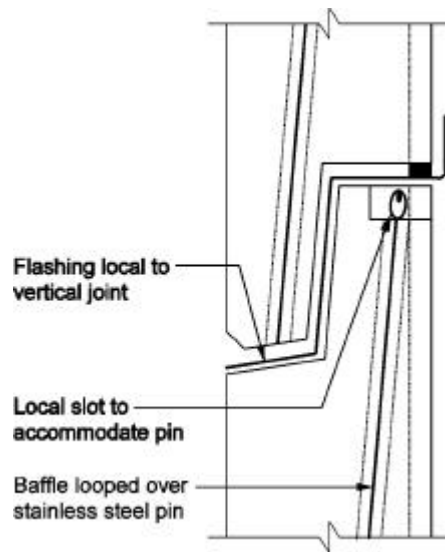
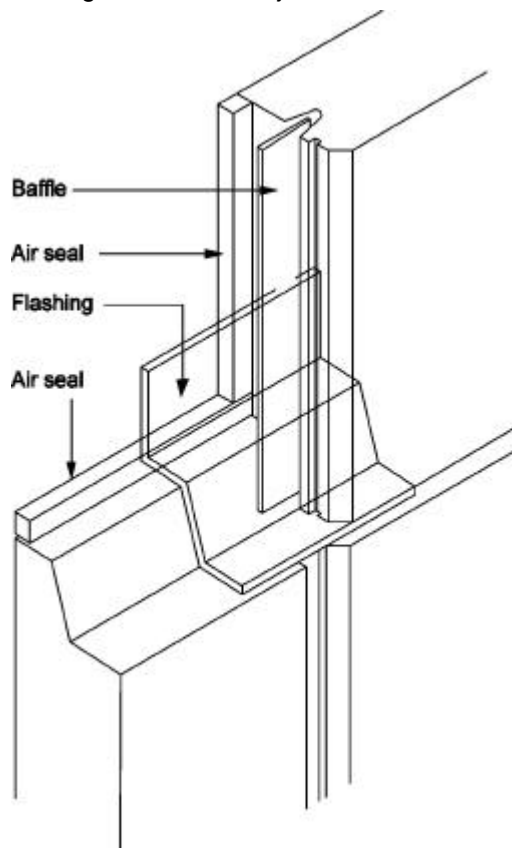

**Figure 2.27 – Fixing of top of baffle in a two-stage horizontal joint**

Figure 2.28 shows a general arrangement at the junction of vertical and horizontal joints.

Junctions are critical to performance, and their important aspects are:

- the continuity of air seals; and
- the provision of a cover flashing over the lower joint.



**Figure 2.28 – Typical intersection between horizontal and vertical two-stage joints in an external wall**

(e) Jointing of precast panels to insitu concrete

Sealing for air and water penetration is primarily provided by the contact between the insitu and precast elements. Reinforcement must be provided to ensure the insitu and precast elements are maintained in intimate contact. A sealant may be applied to form a secondary seal along the joint. It is essential the insitu concrete is well compacted and no grout leakage occurs at the face of the joint.

(i) Vertical joints

A typical vertical joint between precast and insitu wall panels is shown in section A-A of figure 2.29.

(ii) Horizontal joints

A typical horizontal joint between precast and insitu floor slabs is shown in section B-B of figure 2.29.

(iii) Joint intersections

A typical joint intersection between precast and insitu floor slabs is shown in figure 2.29.

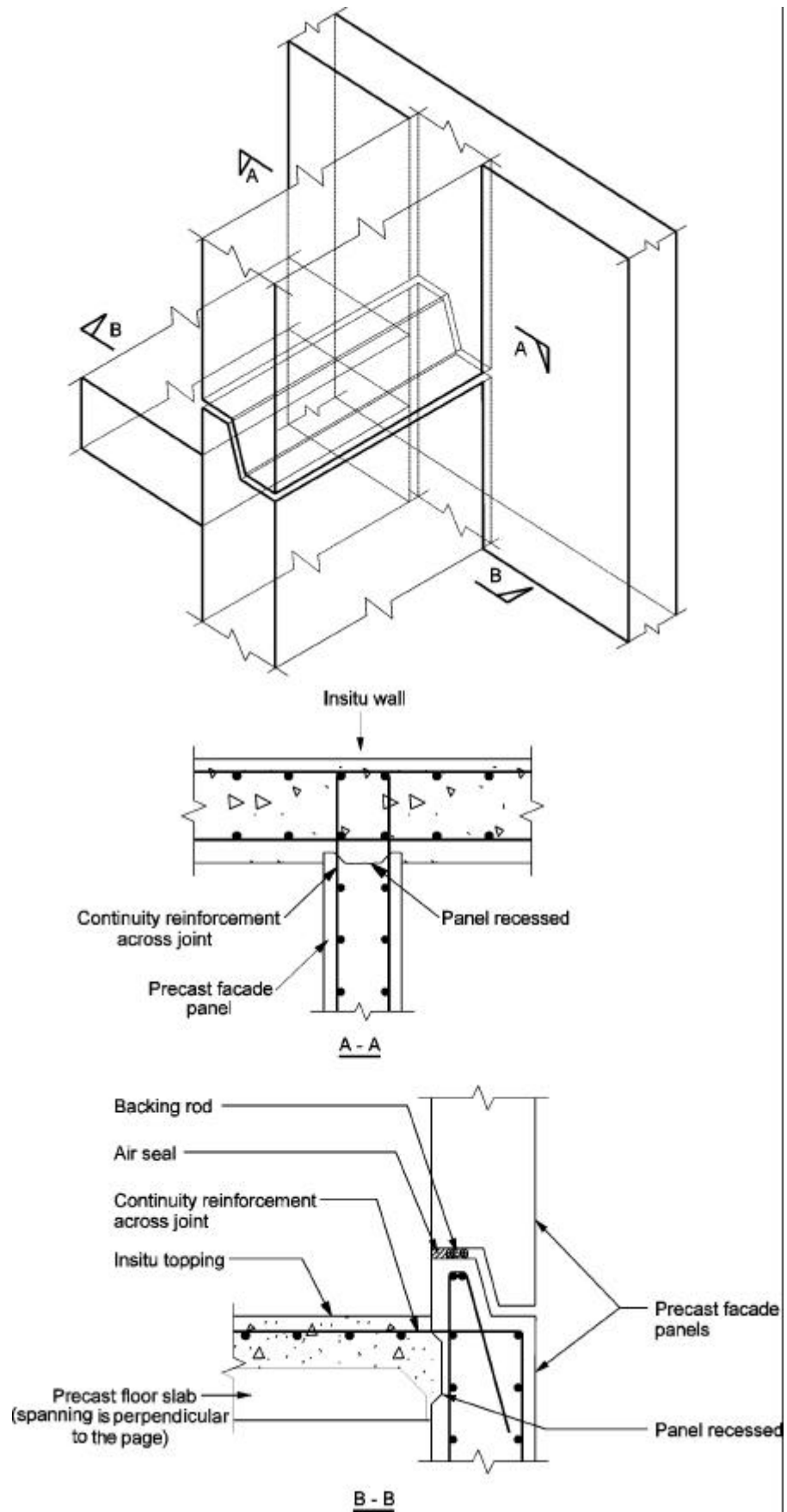

Figure 2.29 – Precast panel to insitu concrete: joint intersection

#### 2.8.2.10 *Testing*

Precast panels often include cast in window frames, and the window assemblies are commonly subjected to tests for the infiltration of air and water. To test the potential joint performance, consideration may be given to incorporating panel to panel joints in the window test assembly.

The most effective test, as it encompasses site workmanship, and also can encompass a large number of joints, is inspection of the completed panel joints for damp or leakage after heavy rain at site.

In the absence of heavy rain, specific joints can be tested by spraying them with water. The hose should deliver water as a spray, not a solid jet, and the water should be directed horizontally, not upward (see clause 4.3.1 for water-tightness testing of façade panels).

#### 2.8.2.11 *Maintenance*

The design of joints should allow for inspection, repair and, if necessary, replacement of deteriorated jointing products during maintenance. All joints should be designed in a manner that should be accessible for inspection and repair without major disruption to the building occupants. However, for practical reasons, the temporary removal of some interior decoration might be necessary.

Building maintenance manuals should be provided to include the following:

- an inspection schedule;
- an expected replacement schedule for jointing products;
- an identification of joints where lack of maintenance would lead to significant consequential damage;
- guidance on how to maintain joints; and
- means to identify products or types of jointing products used.

## **2.9 COMPOSITE CONCRETE CONSTRUCTION**

### **2.9.1 General**

Where reinforced or prestressed precast concrete units are connected with insitu concrete to resist flexure, provision for horizontal shear transfer at the contact surface should be made. Sufficient bond at the interface of the precast element and the insitu concrete should also be provided. Testing should be conducted if necessary.

#### 2.9.1.1 *Analysis and design*

The analysis and design of composite concrete structures and members should be in accordance with the Code of Practice for the Structural Use of Concrete.

#### 2.9.1.2 *Construction methods*

The construction methods used should be compatible with the design of component parts as well as the composite sections. Where props are used, stresses and deflections should be checked to be within allowable.

#### 2.9.1.3 *Relative stiffness*

The relative stiffness of members should be determined from the concrete gross or transformed section. If the concrete strengths of the two components of a composite member differ by more than 10 N/mm<sup>2</sup>, an appropriate allowance should be made.

#### 2.9.1.4 *Precast pre-tensioned units designed as continuous members*

When the designed continuity is made by reinforced concrete cast insitu over the supports, the compressive stresses due to prestress in the ends of the units may be ignored over the transmission length for the tendons.

#### 2.9.1.5 *Differential shrinkage*

(a) General

Differential shrinkage may lead to increased stresses in the composite section where there is an appreciable difference between the age and quality of the concrete in the individual components and these stresses should be checked. The effects are likely to be more severe when the precast component is reinforced concrete or prestressed concrete with an approximately triangular distribution of stress due to prestress. The tensile stresses induced by differential shrinkage should also be considered at design stage.

(b) Tensile stresses

The differential shrinkage coefficient (the difference in total free strain between the two components of the composite member) needs to be established to calculate the resultant tensile stresses. The various factors affecting the coefficient have to be considered and taken in to account.

(c) Approximate value of differential shrinkage coefficient

In the absence of exact data, when designing precast T-beams with an insitu concrete flange, a value of  $100 \times 10^{-6}$  may be assumed for the differential shrinkage coefficient within buildings in a normal environment.

#### 2.9.1.6 *Horizontal shear force due to ultimate loads*

The horizontal shear force due to ultimate load at the interface of the precast and insitu components is either:

- the total compression (or tension) calculated from the ultimate bending moment if the interface is in the tension zone; or
- the compression from that part of the compression zone above the interface, calculated from the ultimate bending moment if the interface is in the compression zone.

#### 2.9.1.7 *Average horizontal design shear stress*

The average horizontal design shear stress is the stress obtained by dividing the design horizontal shear force by the area obtained by multiplying the contact width by the beam length between the point of maximum positive or negative design moment and the point of zero moment.

The average horizontal design shear stress should then be distributed in proportion to the vertical design shear force diagram to give the design ultimate horizontal shear stress at any point along the length of the member. The design shear stress  $v_h$  should be less than the appropriate value in Table 2.10.

**Table 2.10 – Design ultimate horizontal shear stresses at interface**

Precast unit	Surface condition	Insitu concrete grade		
		25 (N/mm <sup>2</sup> )	30 (N/mm <sup>2</sup> )	40 and over (N/mm <sup>2</sup> )
No links	as-cast or as-extruded	0.4	0.55	0.65
	brushed, screeded or rough-tamped	0.6	0.65	0.75
	washed to remove laitance or treated with retarder and cleaned	0.7	0.75	0.80
Nominal links projecting into insitu concrete	as-cast or as-extruded	1.2	1.8	2.0
	brushed, screeded or rough-tamped	1.8	2.0	2.2
	washed to remove laitance or treated with retarder and cleaned	2.1	2.2	2.5

Notes:

1. The description 'as-cast' covers those cases where the concrete is placed and vibrated leaving a rough finish. The surface is rougher than would be required for finishes to be applied directly without a further finishing screed but not as rough as would be obtained if tamping, brushing or other artificial roughening had taken place
2. The description 'as-extruded' covers those cases in which an open-textured surface is produced direct from an extruding machine
3. The description 'brushed, screeded or rough-tamped' covers cases where some form of deliberate surface roughening has taken place but not to the extent of exposing the aggregate
4. For structural assessment purposes, it may be assumed that the appropriate value of  $\gamma_m$  included in the table is 1.5

#### 2.9.1.8 Nominal links

Nominal links with a gross sectional area of at least 0.15% of the contact area should be provided. Spacing should not be excessive. The spacing of links in T-beam ribs with composite flanges should not exceed the greater of four times the minimum thickness of the insitu concrete or 600 mm. Links should be adequately anchored on both sides of the interface.

#### 2.9.1.9 Links in excess of nominal

If the horizontal shear stress obtained in accordance with clause 2.9.1.7 exceeds the value given in Table 2.10, all the horizontal shear force should be designed to be taken by the reinforcement anchored either side of the interface.

The area of steel required  $A_h$  (mm<sup>2</sup>/m) should be calculated from the following equation.

$$A_h = \frac{1000 b v_h}{0.87 f_y}$$

where:  $b$  is the breadth of the section in mm, and

$v_h$  is the design shear stress in N/mm<sup>2</sup> as defined in clause 2.9.1.7

#### 2.9.1.10 Vertical shear

##### (a) General

For composite members resisting vertical shear due to design ultimate loads, the design should be in accordance with the Code of Practice for the Structural Use of Concrete

##### (b) Insitu concrete with precast prestressed units

When the composite concrete section is used in the design of such units, the design principal tensile stress should not exceed  $0.24\sqrt{f_{cu}}$  anywhere in the prestressed units. The stress should be calculated by making due allowance for the construction sequence and by taking 0.8 times the compressive stress due to prestress at the section considered.

#### 2.9.1.11 *Structural topping*

(a) Thickness

The minimum recommended thickness is 40 mm nominal with a local minimum of 25 mm.

(b) Workmanship

Workmanship is important to achieve a good shear connection. Generally, the topping should be well vibrated onto a surface that has been dampened but is free from standing water.

Where electrical conduits and the like are to be included within the structure, the minimum thickness of topping should be increased accordingly.

Under no circumstances should structural topping be used to adjust level differences as a result of erection tolerances thereby resulting in local areas where the thickness is less than the minimum specified above.

#### **2.10 NON-STRUCTURAL ELEMENTS**

Non-structural precast elements, for example façade panels or non-loadbearing partitions, whilst not forming part of the structural framing system of a structure will nonetheless be subjected to selfweight and wind loading. The elements and their connections should therefore be designed in a similar manner to structural precast elements and in accordance with the relevant sections of clauses 2.1 to 2.9. Refer to Appendix A for the typical installation details for precast concrete façade panels.

### **3 CONSTRUCTION**

#### **3.1 PRODUCTION PLANNING**

Detailed planning at the pre-production stage is essential to ensure a safe and successful manufacturing, supply and erection process for a precast concrete system. The manufacturing programme and resources must be synchronised so that the delivery rate matches the project construction requirements and available site storage. Any special transport requirements or site access limitations that may require deliveries outside normal working hours should be identified at this stage.

A lead in time for the fabrication of precasting moulds, trial elements and connections details should be allowed for. Up to six months may not be an unusual period.

Production shop drawings, usually prepared by the precasting manufacturer, should include all necessary information for the following items:

- member shapes (elevations and sections) and dimensions;
- sections and details to indicate quantities and position of reinforcement, anchors, inserts, etc.;
- joint and connection details;
- production tolerances;
- handling devices including specifically fabricated lifting beams/frames and strongbacks;
- finishes;
- bearing seats;
- methods for storage, lifting and transportation; and
- unique identification, location and orientation information which is to be marked on the units.

#### **3.2 MOULDS**

##### **3.2.1 Materials**

Several factors should be considered when choosing the material for constructing precast moulds such as: repetitive use of the mould, economics, required surface finish type and quality and the shape complexity of the precast unit. Environmental aspects should also be considered when selecting a suitable mould material.

The moulds should have adequate stiffness to maintain specified tolerances conforming to shape, lines and dimensions as shown in the contract documents.

Due to the complexity of tailor-made steel moulds for precast concrete façade panels, it is normally considered economical to produce a single steel mould for the construction of 200 or more panels. However, other considerations mentioned above may govern the selection of steel for the use as a mould material.

The design of steel mould is critical because failure of which may lead to delay in programme and also wastage of precast products if it could not achieve the required workmanship and tolerances. Material quality and thicknesses, three-dimensional restraints, demoulding mechanisms, temperature effects are important considerations in designing good moulds.

##### **3.2.2 Tolerances**

Precast concrete units can be manufactured to comparatively close tolerances, although it should be appreciated that, as with insitu concrete, some dimensional variations are inevitable. Manufacturing tolerances should be specified for overall dimensions, thickness, bow, twist, flatness, squareness, size and location of openings and cast-in items. The mould tolerances should be compatible with the construction and erection tolerances specified in the contract documents in order to achieve an acceptable completed precast product.

Repetitive operations such as casting, concrete vibration, mould stripping and re-erection should not affect the mould dimensions beyond permissible tolerances. Regular surveys of the moulds should be made to ensure that they are still within acceptable limits.

As good practice, it is recommended that full re-checking of moulds for dimensional tolerance compliance be carried out after approximately 100 castings. More frequent checking may be advisable.

### **3.2.3 Mould orientation**

Surface finish requirements will often dictate the preferred orientation of a precast element in the mould. The finish quality of vertical mould faces may be inferior to that cast against a horizontal surface.

Thin, lightly reinforced panels are often cast in vertical moulds, or in horizontal moulds that are tilted to vertical before the panel is lifted out. These panels may have insufficient strength to resist gravity loads if laid flat and should be stored, transported and handled in a near vertical position at all times.

### **3.2.4 Recesses, sleeves and boxouts**

These should be formed from suitable material. The shape, size and location should be identified on the precast unit shop drawings.

### **3.2.5 Mould release agents**

Both suction and friction can be reduced by the use of high quality mould releasing agents. These releasing agents should be of a suitable type that will assist in demoulding of the precast unit without causing discolouration, adversely affecting the appearance of the surface finish or reducing the adhesion of subsequent finishes such as tiling. Their application and timing control should adhere strictly to the manufacturer's recommendations.

## **3.3 CAST-IN CONNECTIONS**

Where bars are provided with threaded ends for bolting or sleeve connection, a high degree of accuracy in their location is required. Templates should be used to fix threaded bars, bolts, inserts, sleeves and base plates during the production of precast units and cast insitu elements.

For complicated connections or connection systems which require very tight construction tolerances, mock-up elements should be prepared to ensure any construction difficulties are identified and solved prior to the commencement of mass production of precast units.

## **3.4 LIFTING INSERTS**

### **3.4.1 General**

Proprietary lifting inserts should comply with the design requirements of clause 2.7.5. Reinforcing bars should only be used as lifting eyes when they have been designed to act in that manner. The type of lifting eyes or inserts to be used on a particular project should be agreed between the manufacturer and the contractor/erector.

Lifting inserts should be firmly fixed to the mould in a manner that prevents them moving out of position during concrete placement. Puddling in facelift anchors after pouring of the concrete, while it is still in a plastic state, is a common and accepted technique. Anchors must be cast in at the correct height to accommodate the lifting clutch, hook or shackle that will be used to handle and erect the precast element.

Recess formers should be well maintained and must be compatible with the type of insert that is to be used.

### 3.4.2 Lifting position tolerances

Recommended tolerances on the location of lifting devices for typical precast elements are given in table 3.1 below:

**Table 3.1 – Recommended tolerances for lifting devices**

Type of unit	Location on the unit	Tolerance
Pile		150 mm
Floor slab		150 mm
Beam	Along the length Across the width	300 mm 25 mm
Column	Along the length On the end	300 mm 25 mm
Wall or façade panel	In the face in any direction On the edge across the thickness On the edge longitudinally	25 mm 5 mm 25 mm

## 3.5 SURFACE FINISHES

### 3.5.1 Types of finishes

Various types of finishes can be produced. The more common types are plain (off form) finishes, patterned finishes, tiled finishes and surface finishes treated by tooling, sand blasting or acid etching.

Prior to the commencement of mass production of precast units, trial units should be prepared so that the surface finish quality can be inspected, agreed and approved by all parties concerned. Often, several adjustments and improvements are necessary before the desired product finish is achieved.

### 3.5.2 Production

The quality of a concrete surface finish that can be achieved, is dependent on the properties and constituents of the concrete mix, the type of form material and releasing agent; the placing and compaction of the concrete; and the measures taken to cure the concrete.

### 3.5.3 Tiled finishes

Precast panels may have tiling added after casting, or frequently, where panels are cast flat, the tiling can be placed in the mould before the concrete is poured. Where tiling is added after the panels are cast, a thin bed tile adhesive is commonly used to attach the tiling. Any adhesive should be applied strictly in accordance with the manufacturer's instructions.

Mould releasing agents, curing compounds and the like can significantly reduce the adhesive bond between the tiles and the concrete, therefore care should be taken to ensure that these substances are removed from the concrete surface before the application of any adhesives.

Waterproofing agents are also known to reduce tile/concrete adhesion, and if these are present in the concrete, specialist advice must be sought.

Where tiling is placed directly in the mould, to preserve the joint appearance it is sometimes necessary to initially grout up the joints, and often a layer of adhesive is then applied to the back of the tiles before pouring the concrete. It is however, essential that the concrete is placed before the adhesive set commences thereby reducing the bond. This period is referred to as open time and is particularly critical when reinforcement has to be placed in the mould after adhesive application and prior to concrete placement.

### **3.6 PREFABRICATED METAL FRAMES**

Prefabricated frames such as windows that are to be incorporated into the precast units should be manufactured in accordance with the appropriate standards.

As the frame surfaces may be damaged by fresh concrete, adequately protection should be provided. Where frames are to be cast in fresh concrete, the surface in direct contact with the concrete may have a protective coating if recommended by the supplier.

Prefabricated frames should be manufactured with suitable lugs on the face that is to be in contact with concrete to ensure proper bonding to the precast unit. Frames should be secured in such a way that they cannot move or deform in the mould during concrete placement.

### **3.7 PRE-CONCRETING CHECK**

The following items should be checked prior to concreting:

- overall dimensions;
- squareness of corners and of edges;
- condition of side and base of mould;
- location of cast-in items including starter bars, dowels and lifting inserts etc, and support;
- location of reinforcement and support;
- concrete cover to reinforcement;
- boxouts for openings;
- provision for finishes;
- identification and marking;
- windows.

### **3.8 CONCRETE PLACING**

Placing and compacting of fresh concrete should be carried out under proper supervision. Compaction should be thorough and care should be taken to avoid displacing reinforcement, tendon ducts and anchorages and cast-in items, and to avoid damage to the faces of the mould.

### **3.9 DEMOULDING AND LIFTING**

Precast concrete elements should only be demoulded once the concrete has achieved sufficient strength to withstand the stresses due to the demoulding process and initial handling. Strength may be assessed by tests on cubes cured, as far as possible, under the same conditions as the concrete in the element being considered.

The minimum concrete strength at which precast elements can be lifted from the mould will be determined by the magnitude of the greater of the concrete stresses at the lifting points, the stresses caused by the transfer of prestressing forces or the stresses from handling.

For vertically cast panels, or elements cast on tilting moulds the flexural stresses may not always determine minimum concrete strengths required. In these situations the minimum strength of the concrete at initial lift may be governed by the required capacity of the lifting inserts.

The capacity of lifting inserts may be less than their rated capacity due to short embedment lengths, insufficient edge distances and/or low concrete strengths at the time of lifting. Higher strengths than those recommended in the table below may therefore be required to develop the capacity of some lifting inserts or for safe handling of the elements.

**Table 3.2 – Recommended minimum concrete strengths for lifting and handling**

<b>Application</b>	<b>Minimum concrete strength</b>
None specified, fine controlled crane, non-prestressed	10 N/mm <sup>2</sup> *
Lifting which involves significant impact or high acceleration	15 N/mm <sup>2</sup> *
All units where concrete strength for lifting is specified in the contract documents	as specified
Concentrically prestressed elements (piles, wall panels or thin floor slabs)	20 N/mm <sup>2</sup>
Eccentrically prestressed elements (tees, deep flooring units)	25 N/mm <sup>2</sup>
Bridge beams and similar highly stressed prestressed elements	30 N/mm <sup>2</sup> or as specified
*Dependent on anchor length or as recommended by insert manufacturer	

With prestressed elements special care should be taken to ensure lifting devices are anchored in compression zones, unless covered by specific design.

Initial lifting should be made cautiously and gradually to overcome suction and friction without inducing sudden impact forces.

### **3.10 CURING**

#### **3.10.1 Normal curing**

The method and duration of curing should be such that the concrete will have satisfactory durability and strength, and that the precast unit will not distort and will not cause undue cracking due to shrinkage. Suitable methods of curing include:

- delaying mould removal;
- covering the concrete surface with an impermeable sheet of material, such as polyethylene. The sheet should be well sealed and fastened;
- spraying the concrete surface with an efficient curing membrane;
- covering the concrete surface with a continuously damp absorbent material; or
- continuous or frequent applications of water to the surface, avoiding alternate wetting and drying or application of cold water to warm concrete surfaces.

Surfaces should normally be cured for a period of not less than 4 days.

#### **3.10.2 Steam curing**

Once the placement of concrete is complete, the concrete must be left for 4 hours without additional heating. With steam curing, the concrete temperature can then be raised at a maximum rate of 10 C per half hour. The concrete temperature should at no time exceed 70 C and the rate of subsequent cooling should not exceed the rate of heating.

Steam curing should be under a suitable enclosure such that the live steam can be retained. Steam jets should be positioned to allow free circulation of the steam around the surfaces of the members, and to avoid discharge directly onto the concrete or the test cubes.

### **3.11 HANDLING**

The handling process encompasses the demoulding of the precast units, their loading and transportation to storage areas, offloading and storage, transfer to site and site erection.

To avoid excessive stresses and possible damage, all precast units should be handled in the manner as envisaged in their design by means of approved devices, identified in the production and erection drawings.

The techniques for handling precast units should aim for successful fabrication, delivery and installation without causing structural damage, detrimental cracking, architectural impairment or permanent distortion.

### **3.12 POST-CONCRETING CHECK**

#### **3.12.1 General**

The size and shape of the precast units should be checked for compliance with the contract documents and that they are within specified tolerance limits. Other items should also be checked to ensure the units are acceptable for project use. They include checking that:

- connectors, sleeves, recesses and other features are in their correct location and were not misaligned or dislodged during concreting;
- construction joints have been formed as designed;
- reinforcement protruding from the element is the correct diameter and length and in the correct location;
- surfaces are free from cracks, hollow spot and unevenness, and exhibit no signs of grout loss, major chipping or misalignment of joints;
- earthing lugs when required provide full electrical continuity; and
- identification and marking is correctly attached.

It may be desirable to instigate 2 stages in the checking works:

- stage 1 immediately after demoulding to identify the repairable and non-repairable damages. The non-repairable elements are to be discarded.
- stage 2 post-repairs and post-finishing when the precast units are ready for dispatch.

#### **3.12.2 Production tolerances**

If very close tolerances are likely to be required, it is recommended that the advice of the manufacturer be obtained at an early stage of the design. The tolerance which can be achieved in practice depends on a number of factors including:

- unit shape, particularly the effect on the stiffness of the mould;
- mould materials and the method of mould assembly;
- number of castings from each mould; and
- position and shape of any projections.

Tolerances are given below as a general guide to the accuracy that can be achieved by normal production methods. If more stringent tolerances are necessary they should be restricted to those important dimensions. In this respect, a very high standard of mould construction, together with closer supervision and inspection at all stages of manufacture will be required. The tolerances should be used as guidelines for acceptability and not as limits for rejection. If the specified tolerances are not met, the member may still be accepted if:

- the structural or architectural integrity of the member is not affected;
- the member can be brought within tolerance by structurally and architecturally satisfactory means; or
- the erected assembly can be modified to meet all structural and architectural requirements.

Overall size

- length (major dimensions of unit)
  - up to 3 m ± 6 mm
  - 3 m to 4.5 m ± 9 mm
  - 4.5 m to 6 m ± 12 mm
  - additional deviation for every subsequent 6 m ± 6 mm

- width or height
  - up to 250 mm ± 4 mm
  - 250 mm to 500 mm ± 6 mm
  - 500 mm to 750 mm ± 8 mm
  - additional deviation for every subsequent 250 mm ± 3 mm
- thickness or depth
  - up to 500 mm ± 6 mm
  - 500 mm to 1500 mm ± 8 mm

#### Shape

- straightness or bow (deviation from intended line)
  - up to 3 m 6 mm
  - 3 m to 6 m 9 mm
  - 6 m to 12 m 12 mm
  - additional for every subsequent 6 m 6 mm
- squareness

When considering the squareness of a corner, the longer of two adjacent sides being checked should be taken as the base line. The difference between the greatest and least dimensions of the shorter side's variance to the perpendicular from the base line should not exceed the following:

- length of shorter sides;
- up to 1200 mm 6 mm
  - 1200 mm to 1800 mm 9 mm
  - over 1800 mm 12 mm

For the purpose of this requirement any error due to lack of straightness should be ignored; squareness should be measured with respect to the straight lines that are most nearly parallel with the features being checked.

When the nominal angle is other than 90°, the included angle between check lines should be varied accordingly.

- twist
 

Any corner should not be more than the deviation stated from the plane containing the other three corners:

  - up to 600 mm side and up to 6 m length 6 mm
  - over 600 mm wide and for any length 12 mm

- flatness
 

The maximum deviation from a 1500 mm straight edge placed in any position on a nominally plane surface should not exceed 6 mm.

#### Openings

- window or door
  - width up to 3 m ± 10 mm
  - height up to 3 m ± 10 mm
- internal opening
  - position ± 15 mm
  - dimensions ± 6 mm

## Cast-in items

- window frames ± 15 mm
  
- fixing plates or cleats, position
  - up to 2 m ± 6 mm
  - 2 m to 10 m ± 12 mm
  
- fixing plates or cleats, tipping or flushness ± 3 mm
  
- position of bolt holes centres
  - along length ± 9 mm
  - across width ± 9 mm
  - within group ± 3 mm

### 3.12.3 Surface finish

#### 3.12.3.1 Inspection

The surface of precast units should be inspected for defects and for the conformity with the specifications. The making good of surface defects may be permitted, subject to the approval of the Engineer, but the standard of acceptance should be appropriate to the type and quality of the finish specified.

#### 3.12.3.2 Cracks

Precast units that have been adequately designed for the stresses due to serviceability effects and handling are generally free from cracks when correctly demoulded, transported and handled. However, sometimes cracks may occur as a result of difficulties in demoulding, rough handling, concrete shrinkage and improper concrete mix.

#### 3.12.3.3 Repairs

Any defects found in a precast unit should be checked to ensure that the unit is still aesthetically and structurally acceptable for use after an appropriate repair is made.

The type of repair material and method depends on the pattern, extent of the defect and type of surface finish and should be agreed by all parties involved and approved by the Engineer. The repair materials and method should be effective and acceptable in terms of achieving the required concrete strength and structural integrity as well as producing a texture and colour similar in appearance to the surrounding surface.

### 3.13 LIFTING EQUIPMENT AND ACCESSORIES

Lifting equipment such as mobile crane, gantry crane, forklift etc. must be carefully selected to ensure that lifting of precast units is carried out within the rated capacity of the equipment. The support for the lifting equipment must be checked to ensure that adequate supporting capacity is provided.

Lifting accessories may comprise combinations of lifting beams or frames, slings or cables, hooks or shackles. The selection of each of these components should be predetermined to take account of the forces exerted on them due to all aspects of the lifting operations. A person suitably qualified in accordance with the relevant regulations must regularly inspect all lifting equipment prior to and after use. Results of such inspections must be properly recorded and be available for subsequent inspection by the Engineer upon request.

Some precast elements such as prestressed hollow-core floor slabs must be handled by means of lifting clamps, strops or slings as they may have no lifting inserts. Lifting equipment of this type may wear rapidly and therefore should be regularly inspected. The location of lifting points should be clearly indicated on the drawings.

### **3.14 FACTORY AND SITE STORAGE**

Storage areas must be large enough so that the precast units can be stored safely, with adequate room for lifting equipment and transporting vehicles to manoeuvre. The ground of the storage area must be hard, level, clean and well drained to permit organised storage.

Precast elements can be damaged by incorrect stacking and storage. Where the locations of support points for a precast unit are critical the locations for the supports (dunnage) should be noted on the shop drawings.

Supports must be arranged to avoid twisting or distorting of the precast elements and must be adequate to transfer the weight of the stacked units to the ground without excessive settlement.

The stored and stacked units should be protected to prevent accidental damage and discolouration and the support material should be non-staining. Lifting points should also be well protected and kept accessible while the units are in storage.

Precast units must be stored safely with adequate supports such that it would not endanger any workers moving in the vicinity.

### **3.15 TRANSPORTATION**

#### **3.15.1 Delivery**

Commonly precasting factories lie outside the Hong Kong SAR, in Guangdong province China, and in order to get the products to the construction site it is necessary for road and/or water transportation.

For transportation within China regional authority transportation requirements will need to be met and permits, where applicable, obtained. Within the Hong Kong SAR, transportation must comply with the appropriate regulations.

The precast units should have gained sufficient strength before being loaded for transportation.

#### **3.15.2 Loading and storage on transporters**

Precast units must be loaded carefully on to delivery vehicles to prevent damage. To protect the edges throughout their journey, proper devices should be used to support, secure and wedge the precast units. The units should be adequately secured and supported to prevent them from overturning, shifting or being damaged during transportation. Adequate non-staining cushioning should be provided between the unit and any securing chains, cables or ropes to prevent localised damage.

Precautions should also be taken to ensure that no undesirable stresses will be transmitted to the precast unit due to any flexing of truck or barge deck.

### **3.16 ERECTION**

#### **3.16.1 Erection preparation**

Consideration should be given to the following items to ensure safe and efficient installation of the precast elements in accordance with the design intent:

- erection sequence;
- assembly and erection method;
- erection tolerances;
- rigging requirements;
- concrete strength or age requirements;
- permanent structural connection and joint details; and
- propping and temporary support details.

If the sequence of erection is critical to the structural stability of the structure, or for access to connections at certain locations, it should be noted on the drawings. The erection drawings, which should include all relevant information, should be prepared prior to the commencement of any erection.

### 3.16.2 Erection safety

Safety during the handling and erection of precast concrete elements is of paramount importance and compliance with the relevant current regulations is required.

All equipment used for the handling and erection of a precast element must be maintained to a high standard, load tested as necessary, and be suited to the intended use.

Consideration should also be given to the site environment particularly with regards to built up areas and implications this may have on erection safety.

### 3.16.3 Erection sequence

Precast elements should be erected in accordance with a pre-planned sequence as detailed in the erection drawings. This sequence of erection should be such that the multiple handling of elements is minimised. A trial erection operation should be considered to identify any unforeseen erection difficulties.

### 3.16.4 Missing or damaged lifting inserts

If missing, faulty or incorrectly located lifting inserts are identified, the designer should be contacted immediately to assess the problem and decide on an alternative lifting system.

It should be verified, where permanent fixings or connections are temporarily used during construction, that the fixings are suitable for the temporary use and their long-term performance will not be compromised.

### 3.16.5 Erection tolerances

Generally, the precast unit should be erected in accordance with the following tolerances, unless other tolerances are used in the design and specifications:

Space between elements;

- |                           |                          |         |
|---------------------------|--------------------------|---------|
| • walls up to 7 m apart   | - at floor               | ± 15 mm |
|                           | - at soffit              | ± 18 mm |
| • columns up to 7 m apart | - at floor               | ± 13 mm |
|                           | - at soffit              | ± 13 mm |
| • beams and floor slabs   | - floor to soffit height | ± 19 mm |

Size and shape of elements and components;

- |  |  |         |
|--|--|---------|
| • walls  | - straightness in 5 m                                    | ± 6 mm  |
|  | - abrupt changes in continuous surface                   | ± 3 mm  |
|  | - verticality in any 3 m length                          | 6 mm    |
|  | - entire height of building or 30 m whichever is greater | 25 mm   |
| • columns  | - verticality up to 3 m                                  | 10 mm   |
|  | - verticality up to 7 m                                  | 14 mm   |
| • beams  | - level variation from target plane                      | ± 23 mm |
|  | - straightness in 6 m                                    | 8 mm    |
| • suspended structural floor before laying of screed | - level variation from target plane:                     |         |
|  | - precast slab   | ± 28 mm |
|  | - structural soffit                                      | ± 18 mm |
| • building   | - length or width up to 40 m                             | ± 38 mm |

Position on plan in relation to the nearest reference line at the same level;

- walls ± 14 mm
- columns ± 10 mm
- finished stairs (flight from landing to landing) ± 10 mm
- doors, windows and other openings ± 10 mm

Position in elevation in relation to the nearest reference line; and

- doors, windows and other openings ± 15 mm

Deviation in level with reference to nearest datum;

- structural roof
  - upper surface height up to 30 m ± 20 mm
  - for each subsequent 30 m ± 10 mm
- stairs
  - vertical height of any flight between landings ± 15 mm
  - difference in rise of any consecutive steps ± 4 mm
  - difference in level of tread with going ± 4 mm
- doors windows and other openings
  - Sill and soffit, for each 1 m of width (maximum 15 mm) ± 6 mm

Note: Values for space between elements take into account variabilities due to position, verticality, straightness/bow and cross section, and should not be combined with values for the latter items.

### 3.16.6 Rigging

A rigging system for handling and erecting precast elements requires careful and thorough pre-planning. Special care must be taken with rigging arrangements where unequal insert loading has been incorporated in the panel design.

It may be necessary to equalise loads between lifting points on certain precast elements, such as beams or flat slabs. Particular care should be taken to determine when this is necessary.

Lifting accessories may be in the form of slings/cables, hooks or shackles. The selection of such components should take into consideration the forces due to all operations involved in the handling and erection of the precast units. Headroom availability and manoeuvrability during erection may also have an impact on the type of rigging system selected.

Refer to Figure 3.1 for some common rigging configurations.

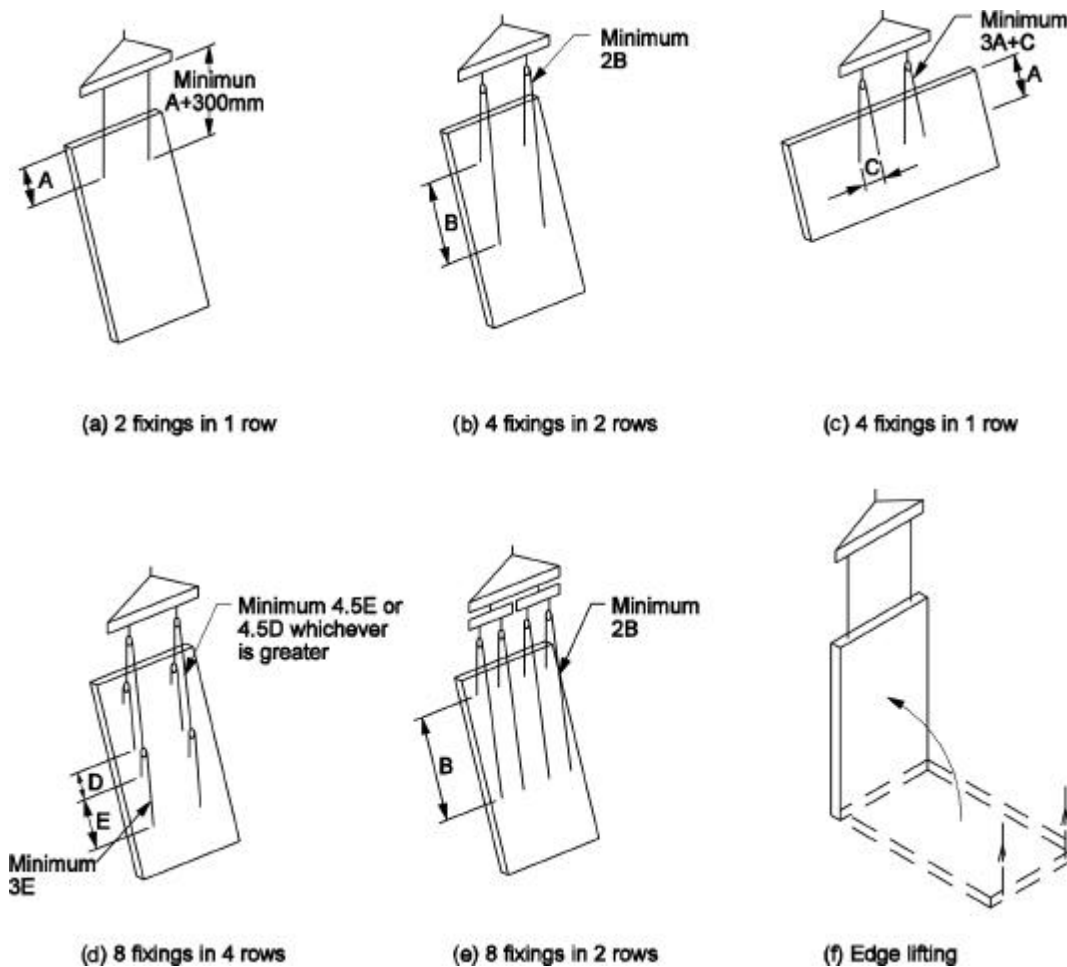

Figure 3.1 – Common rigging configurations

### 3.16.7 Temporary bracing and supporting structures

Precast concrete elements must be adequately braced and supported during all phases of erection to ensure proper alignment and structural integrity until permanent structural connections have been completed.

The design of temporary bracing and supporting structures should comply with clause 2.7.6. The installation and erection is to be in accordance with the approved drawings and checked by a competent person as set out in the project's Site Safety Supervision Plan.

Wherever possible bracing should be fixed to the element before lifting. When it is necessary to attach the braces after the element has been positioned, the element should not be detached from the crane until the braces have been installed.

Bracing bolts should be checked at regular intervals to ensure that they are secure and undamaged.

### 3.16.8 Levelling shims

Levelling shims should be formed from a suitably durable material and should have adequate strength to carry the full imposed loads. Direct concrete to concrete, or concrete to steel bearing should be avoided.

Levelling shims carry the full construction load of the precast element and must provide adequate support to prevent movement until the element is incorporated in the main structure. Levelling shims must therefore be used on a solid foundation. It is recommended that levelling shims are not placed on thin layers of site concrete.

Shimming should not exceed a height of 30 mm unless steps are taken to ensure stability of the temporary support.

Where possible, shims for levelling precast elements should be located at least 300 mm from the ends of the element. This is relevant where edge break-out can occur if shims are placed close to bottom corners, such as for thin wall panels.

If steel shims are used they must be removed before the final grouting up of the joint.

### **3.16.9 Propping**

All temporary propping requirements must be shown on the erection drawings. The design of temporary propping systems should be in accordance with clause 2.7.4. Consideration should be given to the following:

- propping that supports beams should accommodate possible changes to the distribution of loads during the construction process;
- the seating of precast beams may not be adequate to transfer high loads during construction and precast beams will normally require full propping at each end;
- if the structural design requires beams to be supported without the use of mid-span props (to reduce the end support dead load bending moments) this requirement must be clearly noted on both the contract drawings and the precast layout drawings;
- where beams have floor systems placed on them prior to the beams being fully built into the structure, the beams may not be evenly loaded by the floor units during construction. Long span floor units placed on one side only of a beam may cause the beam to roll on the props. In such circumstances each edge of the beam may require separate temporary propping;
- all temporary propping should be in place, adjusted to the correct levels allowing for any required cambers, and fully braced prior to commencement of erection of any precast beams, unless specific provision has been made to do otherwise;
- temporary propping should provide full support for all construction loads including the full self weight of the completed floor system and possible local concentrations of load during construction, unless specifically noted otherwise;
- required duration of propping time and sequence of de-propping;
- all temporary propping should be in place, adjusted to the correct levels allowing for any required cambers, and fully braced prior to commencement of erection of any floor units, unless specifically noted otherwise; and
- props should be vertical and braced to prevent side-sway of the whole assembly and the buckling of individual props.

## **4 QUALITY CONTROL**

### **4.1 FACTORY**

#### **4.1.1 General**

A factory selected for the casting of units must ensure that the precast units are manufactured under a Quality Assurance Scheme certified under ISO 9000 covering the following items:

- quality control tests of materials;
- calibration of laboratory equipment for quality control tests; and
- production process and control of equipment at the casting yard.

The factory and contractor are responsible for maintaining the quality of the manufacturing process for the precast units. A consultancy firm independent of the factory should be appointed by any parties to conduct regular technical audits by their suitably qualified representative. The recommended minimum frequency of auditing is once per month.

The authorised person/registered structural engineer must satisfy himself that the precast concrete units have been constructed in accordance with the Approved Drawings and specification. This may be achieved by providing full time construction supervision by their representative. Should more stringent control be considered necessary, the authorized person / registered structural engineer may step up the supervisory and testing requirements.

Rigorous quality control procedures must be maintained at the precasting factory at all times to ensure that the precast elements are constructed in accordance with the Building (Construction) Regulations and specification.

Upon leaving the precasting factory all precast units or batch of units must carry documentation certified by the factory stating that the units have been manufactured under a certified quality assurance scheme and in accordance with the specification.

#### **4.1.2 Testing standards**

##### **4.1.2.1 Concrete**

Sampling and testing of concrete should comply with the Building (Construction) Regulations and as required by the contract documents in accordance with CS1:1990 or similar approved. The testing is to be undertaken by a HOKLAS or equivalent approved accredited laboratory.

##### **4.1.2.2 Reinforcement**

Sampling and testing of reinforcement should comply with the Building (Construction) Regulations. All testing is to be undertaken by a HOKLAS or equivalent approved accredited laboratory and in accordance with CS2:1995 or similar approved.

##### **4.1.2.3 Grouting**

All grouting should be prepared, applied and tested in accordance with the manufacturer's specification and requirements.

### **4.2 SITE**

The receiving, lifting, storage and erection at the construction site should be undertaken in accordance with the site accredited quality assurance scheme.

The following items should form part of the site checking for acceptance of the precast elements:

- Structural integrity  
Although quality control checks are carried out for the precast units at the factory, there is a possibility of damage during handling and transportation. As the precast units are received on site they should be visually inspected for any signs of structural defect. Acceptance of any structural defect should be assessed with regard to the causes and the overall structural integrity of the precast units;
- Dimensional tolerance

Dimensional tolerances of the precast units as received on site should comply with those specified in the contract documents. See clause 3.12.2 for guidance on production tolerances.

Changes to the dimensions and shapes of units should be identified and assessed with regard to the overall tolerance; and

- **Surface finish**

The surface finishes of precast units when received on site should be checked for compliance with the requirements of the contract documents.

### **4.3 SPECIAL TESTING**

#### **4.3.1 Watertightness testing of external precast façade panels**

##### *4.3.1.1 General*

If it is deemed necessary to demonstrate that the precast façade joints are adequate to resist water penetration, a water penetration test on a full scale panel including joint mock-ups could be undertaken. The recommended testing procedure is outlined in clauses 4.3.1.2 to 4.3.1.5.

##### *4.3.1.2 Test procedures*

Mock-up panels to be tested for watertightness should be subjected to both static and cyclic pressure in accordance with ASTM E331-96 and ASTM E547-96 respectively. These testing procedures are to be modified for local conditions as follows:

- differential test pressure shall be 20% of the maximum inward design wind load but not less than 0.77 kPa; and
- the test shall be performed with water flow rate of 3.4 litres/min/m<sup>2</sup> for 15 minutes.

##### *4.3.1.3 Sampling for water penetration test*

Full scale watertightness testing on precast façade panels and joints should be carried out at the rate of 0.5% for each type of joint and combination of panels or one for each type of joint and precast unit, whichever is the greater.

##### *4.3.1.4 Failure criterion*

The façade units or joints are deemed to have failed if signs of water seepage through the joints or through the façade unit, including signs of damp patches, are observed during the test or within the subsequent 2 hours after the test.

##### *4.3.1.5 Remedial action*

Upon failure of a water penetration test on a precast façade system the cause of failure should be identified and the system revised and re-tested until a satisfactory test result is achieved. Modifications must be realistic in terms of job conditions and must maintain standards of quality and durability.

#### **4.3.2 Load testing**

In cases where non-compliance, supervision indicates poor workmanship or where there are visible defects particularly at critical sections, tests to determine the concrete strength and the quality of materials as deemed necessary may be carried out.

If load testing is made as a requirement for acceptance, then sampling rates should be given in the technical schedule or in the specification. The basis of the overall approach should be for the assessment of both serviceability and strength, in which case overload tests on ultimate strength would not normally be required. Should doubt exist about the ultimate strength of a series of units, then tests to failure may be necessary, at a rate to be agreed by all the parties concerned. In such tests, the performance should be in accordance with that expected from the design calculations. In general, the ultimate strength should exceed the design ultimate load by a margin of at least 5%. Moreover, the deflection, up to the design ultimate load, should not exceed 1/40 of the span.

### **4.3.3 Tiled finishes**

Performance testing should be carried out on a number of trial panels at the precasting yard, to demonstrate the method and materials used for fixing the tiles will be satisfactory in service.

There should be no hollow sounding areas behind the tiles when the surface is tapped with a light hammer or coin.

Pull off tests may be required on selected areas of tiling.

A cover meter survey of reinforcement beneath the tiled finish should be made to ensure adequate cover to reinforcement has been provided.

The number of trial panels, the number and nature of tests, and the acceptance values should be specified and agreed before manufacture.

Acceptance testing on production panels should be carried out at an appropriate time, to avoid the erection of panels with unacceptable finishes. Any of the recommended testing may be employed, but it should be noted that pull off testing is destructive, and the tested area cannot easily be repaired to the original appearance.

**Standards referred to:**

Hong Kong Building (Construction) Regulations

Hong Kong Code of Practice for The Structural Use of Concrete 1987

Hong Kong Code of Practice for Fire Resisting Construction – 1996

Hong Kong Structures Design Manual for Highways and Railways

Hong Kong Code of Practice on Wind Effects – 1983

British Standard BS 6213:2000 Guide to Selection of Construction Sealants

**References**

In preparation of certain clauses, details, tables and figures, reference has been made to the following:

British Standard BS 8110:1985	Code of Practice for The Structure Use of Concrete
British Standard BS 5606:1990	Guide to Accuracy in Buildings
British Standard BS 6093:1993	Code of Practice for Design of Joints in Building Construction
Singapore Standard CP81:1999	Precast Concrete Slab and Wall Panels
Draft New Zealand Code of Practice	The Safe Handling, Transportation and Erection of Precast Concrete
The Institution of Structural Engineers	Structural Joints in Precast Concrete 1978
PCI Design Handbook	Precast and Prestressed Concrete 5th Edition

**Acknowledgements**

Extracts from British Standards are reproduced with the permission of BSI under license number 2002SK/0282. British Standards can be obtained from BSI Customer Services, 389 Chiswick High Road, London W4 4AL, United Kingdom. (Tel + 44(0) 20 8996 9001). Email: [cservices@bsi-global.com](mailto:cservices@bsi-global.com)

Extracts from the Institution of Structural Engineers' publication 'Structural Joints in Precast Concrete' are reproduced with the permission of The Institution of Structural Engineers, 11 Upper Belgrave St, London SW1 88H, United Kingdom.

## **Appendix A**

### **Precast Concrete Façade Typical Details**

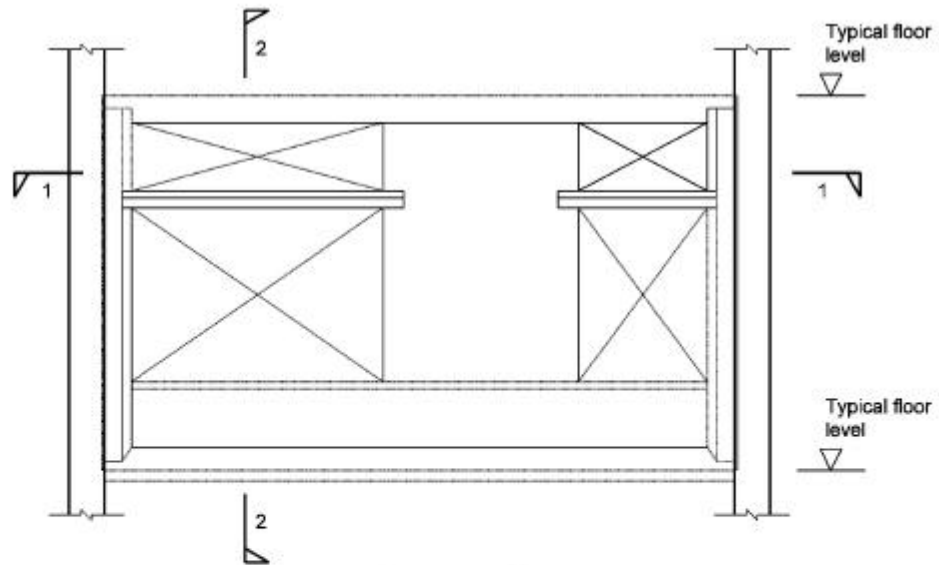

**Elevation of precast facade**

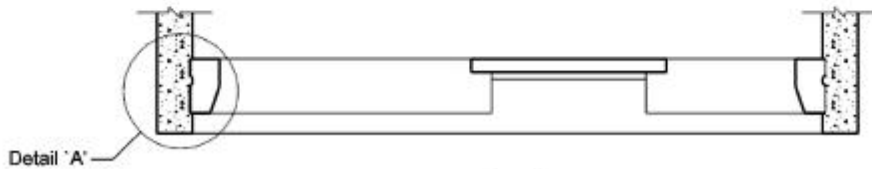

**1 - 1**

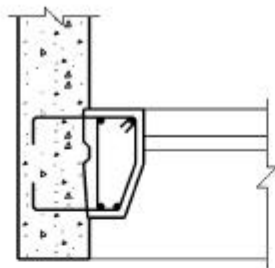

**Detail 'A'**

Simply supported joint details  
to connect to insitu shearwall

- Points to consider:
- i) Weight of facade
  - ii) Dimensions for transportation
  - iii) Connection details
  - iv) Water tightness
  - v) Lateral wind load stability and analysis
  - vi) Movement consideration

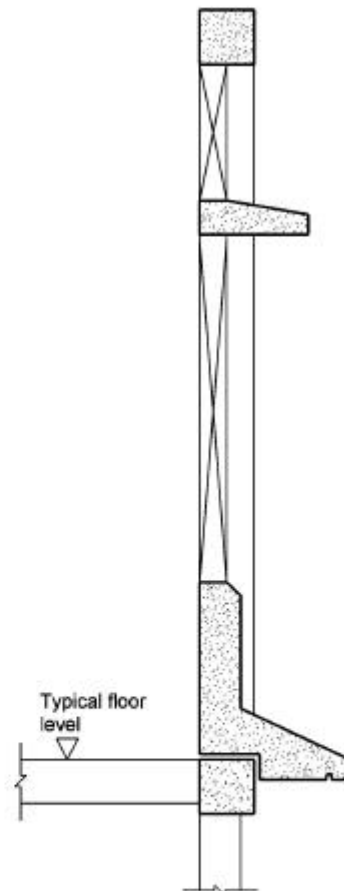

**Permanent Stage**

**2 - 2**

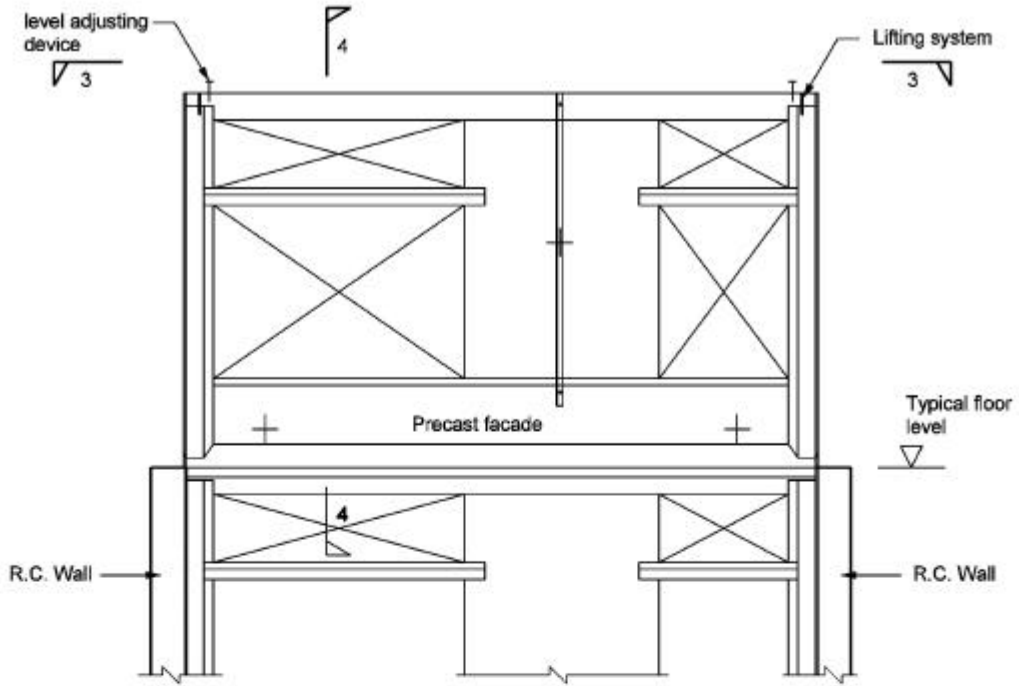

Elevation of precast facade

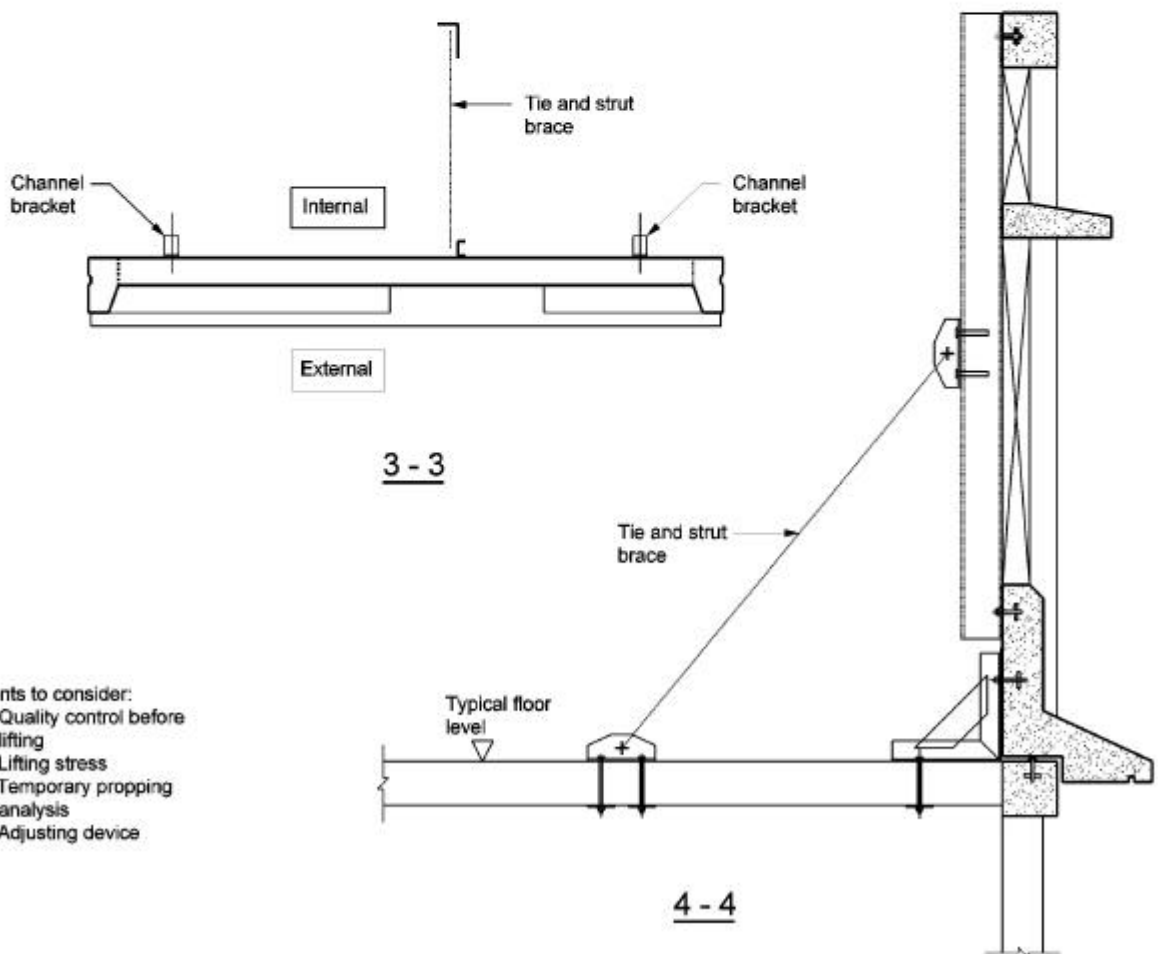

- Points to consider:
- i) Quality control before lifting
  - ii) Lifting stress
  - iii) Temporary propping analysis
  - iv) Adjusting device

Installation stage