

CODE OF PRACTICE FOR THE STRUCTURAL USE OF STEEL

2011
(2023 Edition)



**Code of Practice
for
the Structural Use of Steel
2011
(2023 Edition)**





FOREWORD

The Buildings Department (BD) established the Technical Committee on the Code of Practice for the Structural Use of Steel (TC) in 2008 for the purpose of collecting views and feedbacks on the use of the Code of Practice for The Structural Use of Steel 2005 (the 2005 Code) from the construction industry and keeping the code of practice in pace with the advancement in design and technology.

The Code of Practice for the Structural Use of Steel 2011 (the 2011 Code) was issued in October 2011 after a three-year review of the 2005 Code and consideration of the latest design and technology of steel construction by the TC. It not only provides full guidance on how the relevant requirements of the Buildings Ordinance may be complied with, but also offers an up-to-date reference and new features in steel design and construction for practising engineers and practitioners of the construction industry.

Taking into account the advice of the TC, amendments to the 2011 Code were promulgated in November 2016 and May 2021, and the 2011 Code (2021 Edition) was published in August 2021. Further amendments to the 2011 Code (2021 Edition) introducing, among others, the use of high strength steel Class 1H for use in the construction industry were promulgated in March 2023.

Consolidating all the previous amendments as recapitulated below, this 2011 Code (2023 Edition) was promulgated in March 2023:

Date of Amendment	Reference
November 2016	https://www.bd.gov.hk/doc/en/resources/codes-and-references/code-and-design-manuals/OldVersions/CoP_Steel_ov.zip
May 2021	
2011 Code (2021 Edition) in August 2021	
2011 Code (2023 Edition) in March 2023	https://www.bd.gov.hk/doc/en/resources/codes-and-references/code-and-design-manuals/SUOS2011.pdf 

The contributions and efforts given by the members of the TC in the preparation of the 2011 Code and providing advice on the subsequent amendments of the Code are greatly appreciated.

Although this code of practice is not a statutory document, the compliance with the requirements of this code of practice is deemed to satisfy the relevant provisions of the Buildings Ordinance and related regulations.

This 2011 Code (2023 Edition) is available for viewing in the BD website www.bd.gov.hk under the “Codes, design manuals and guidelines” page of the “Resources” section. This code of practice may be downloaded subject to terms and conditions stipulated in the website.

First issue : October 2011
Second issue : August 2021
This revision : March 2023

CONTENTS

Foreword	i
Contents	ii
List of Figures	xiii
List of Tables	xv
1 GENERAL	1
1.1 Scope	1
1.2 Design Philosophy	2
1.2.1 <i>Aims of structural design</i>	2
1.2.2 <i>Design responsibility and assumptions</i>	2
1.2.3 <i>Structural system, integrity and robustness</i>	3
1.2.4 <i>Overall stability</i>	3
1.2.5 <i>Limit State Design</i>	3
1.2.6 <i>Economy</i>	3
1.2.7 <i>Design working life</i>	3
1.3 References	4
1.4 Glossary of Terms and Definitions	4
1.4.1 <i>General definitions</i>	4
1.4.2 <i>Structural element definitions</i>	5
1.4.3 <i>Structural behaviour definitions</i>	6
1.4.4 <i>Material behaviour definitions</i>	7
1.4.5 <i>Section type definitions</i>	7
1.4.6 <i>Connection definitions</i>	8
1.5 Major Symbols	8
2 LIMIT STATE DESIGN PHILOSOPHY	17
2.1 GENERAL	17
2.1.1 <i>Introduction</i>	17
2.1.2 <i>Simple design</i>	17
2.1.3 <i>Continuous design</i>	17
2.1.4 <i>Semi-continuous design</i>	17
2.1.5 <i>Design justification by tests</i>	17
2.1.6 <i>Performance-based design</i>	17
2.1.7 <i>Calculation accuracy</i>	18
2.1.8 <i>Foundation design</i>	18
2.2 LIMIT STATE PHILOSOPHY	18
2.3 ULTIMATE LIMIT STATES (ULS)	19
2.3.1 <i>Limit state of strength</i>	19
2.3.2 <i>Stability limit states</i>	19
2.3.3 <i>Fatigue</i>	20
2.3.4 <i>Structural integrity and robustness</i>	23
2.3.5 <i>Brittle fracture</i>	26
2.4 SERVICEABILITY LIMIT STATES (SLS)	26
2.4.1 <i>Serviceability loads</i>	26
2.5 LOADING	26
2.5.1 <i>General</i>	26
2.5.2 <i>Dead and imposed loading</i>	26
2.5.3 <i>Wind loading</i>	26
2.5.4 <i>Loads from earth and water pressure</i>	27
2.5.5 <i>Load effects from differential settlement of foundations</i>	27
2.5.6 <i>Load effects from temperature change</i>	27
2.5.7 <i>Loads from cranes</i>	27
2.5.8 <i>Notional horizontal forces</i>	28
2.5.9 <i>Exceptional loads and loads on key elements</i>	29

2.5.10	Loads during construction.....	29
2.5.11	Loads on temporary works in construction	29
3	MATERIALS.....	30
3.1	STRUCTURAL STEEL	30
3.1.1	General	30
3.1.2	Design strength for normal strength steels and high strength steels	31
3.1.3	Design strength for ultra high strength steels	37
3.1.4	Uncertified steel	37
3.1.5	Through thickness properties	37
3.1.6	Other properties	37
3.2	PREVENTION OF BRITTLE FRACTURE.....	37
3.2.1	Procedure	38
3.2.2	Determination of maximum permissible values of element thickness	39
3.3	BOLTS	40
3.3.1	Normal bolts.....	40
3.3.2	High strength friction grip or preloaded bolts	40
3.4	WELDING CONSUMABLES.....	40
3.5	STEEL CASTINGS AND FORGINGS	40
3.6	MATERIALS FOR GROUTING OF BASEPLATES	40
3.7	MATERIALS FOR COMPOSITE CONSTRUCTION	40
3.7.1	Concrete	40
3.7.2	Reinforcement.....	40
3.7.3	Profiled steel sheets.....	41
3.7.4	Shear studs.....	41
3.8	COLD-FORMED STEEL MATERIAL PROPERTIES.....	41
3.8.1	Mechanical properties.....	41
4	LOAD FACTORS AND MATERIAL FACTORS.....	44
4.1	PARTIAL SAFETY FACTORS.....	44
4.2	MATERIAL FACTORS.....	44
4.2.1	Steel plates and sections	44
4.2.2	Bolts	45
4.2.3	Reinforcement and concrete in composite design.....	45
4.2.4	Grout for base plates and wall plates	45
4.3	LOAD FACTORS AND COMBINATIONS	45
4.3.1	Load combinations for normal ultimate limit state.....	45
4.3.2	Load combinations for overhead traveling cranes.....	46
4.3.3	Load combinations for building assessment.....	46
4.3.4	Load combinations for temporary works in construction	46
4.3.5	Load combinations for exceptional events.....	46
4.3.6	Summary of partial load factors	47
4.3.7	Load combinations for serviceability limit states	47
5	SERVICEABILITY LIMIT STATES	48
5.1	GENERAL.....	48
5.2	DEFLECTION	48
5.3	WIND INDUCED VIBRATION.....	49
5.3.1	Wind sensitive buildings and structures.....	49
5.3.2	Serviceability limit state.....	49
5.3.3	Dynamic structural characteristics	49
5.3.4	Serviceability criteria for tall buildings.....	49
5.3.5	Serviceability criteria for communication and broadcasting towers	50
5.3.6	Reduction of wind induced dynamic response	50
5.4	HUMAN INDUCED FLOOR VIBRATION	50
5.5	DURABILITY	51
5.5.1	General	51
5.5.2	Types of protection against corrosion	51
5.5.3	Corrosion from residual stresses	53

6	DESIGN METHODS AND ANALYSIS	54
6.1	METHODS OF ANALYSIS	54
6.2	ANALYSIS MODELS AND ASSUMPTIONS	55
6.3	FRAME CLASSIFICATION	55
6.3.1	<i>General</i>	55
6.3.2	<i>Elastic critical load factor</i>	55
6.3.3	<i>Non-sway frames</i>	56
6.3.4	<i>Sway frames</i>	56
6.3.5	<i>Sway ultra-sensitive frames</i>	56
6.4	IMPERFECTIONS	56
6.4.1	<i>General</i>	56
6.4.2	<i>Frame imperfections</i>	57
6.4.3	<i>Member imperfections</i>	57
6.4.4	<i>Elastic critical mode</i>	58
6.5	SIMPLE DESIGN	58
6.6	FIRST-ORDER LINEAR ELASTIC ANALYSIS (FIRST-ORDER INDIRECT ANALYSIS)	58
6.6.1	<i>General</i>	58
6.6.2	<i>Moment amplification for sway frames</i>	59
6.6.3	<i>Effective length for sway and non-sway frames</i>	59
6.6.4	<i>Maximum slenderness ratio</i>	61
6.7	SECOND-ORDER P-Δ-ONLY ELASTIC ANALYSIS (SECOND-ORDER INDIRECT ANALYSIS)	61
6.7.1	<i>General</i>	61
6.7.2	<i>Method of analysis</i>	61
6.7.3	<i>Applications and limitations</i>	61
6.8	SECOND-ORDER P-Δ-δ ELASTIC ANALYSIS (SECOND-ORDER DIRECT ANALYSIS)	62
6.8.1	<i>General</i>	62
6.8.2	<i>Method of analysis</i>	62
6.8.3	<i>Applications and limitations</i>	62
6.9	ADVANCED ANALYSIS	63
6.9.1	<i>General</i>	63
6.9.2	<i>Method of analysis</i>	63
6.9.3	<i>Applications and limitations</i>	63
6.10	BRACING MEMBERS	63
6.11	CONNECTION CLASSIFICATION IN ANALYSIS	64
6.11.1	<i>Pinned connections</i>	64
6.11.2	<i>Rigid connections</i>	64
6.11.3	<i>Semi-rigid connections</i>	64
7	SECTION CLASSIFICATION	65
7.1	GENERAL	65
7.2	CLASSIFICATION	66
7.3	STRESS RATIOS FOR CLASSIFICATION	70
7.4	FLANGES OF COMPOUND I- OR H-SECTIONS	71
7.5	EFFECTIVE PLASTIC MODULUS	72
7.5.1	<i>General</i>	72
7.5.2	<i>I- or H-sections with equal flanges</i>	72
7.5.3	<i>Rectangular hollow sections</i>	72
7.5.4	<i>Circular hollow sections</i>	73
7.6	EFFECTIVE WIDTH METHOD FOR SLENDER CROSS-SECTIONS	73
7.7	EFFECTIVE STRESS METHOD FOR SLENDER CROSS-SECTIONS	73
7.8	SHIFT OF THE CENTROID OF THE EFFECTIVE CROSS-SECTION	74
8	DESIGN OF STRUCTURAL MEMBERS	76
8.1	GENERAL	76
8.2	RESTRAINED BEAMS	76

8.2.1	Shear capacity	76
8.2.2	Moment capacity	77
8.2.3	Beams with web openings	78
8.2.4	Castellated beams	79
8.3	LATERAL-TORSIONAL BUCKLING OF BEAMS	80
8.3.1	Intermediate and end lateral restraints	80
8.3.2	Torsional restraint.....	81
8.3.3	Normal and destabilizing loads	81
8.3.4	Effective length for lateral-torsional buckling	81
8.3.5	Moment resistance to lateral-torsional buckling.....	83
8.4	PLATE GIRDERS	92
8.4.1	Design strength.....	92
8.4.2	Minimum web thickness for serviceability.....	92
8.4.3	Minimum web thickness to avoid compression flange buckling	92
8.4.4	Moment capacity of restrained girders.....	92
8.4.5	Effects of axial force.....	93
8.4.6	Shear buckling resistance.....	93
8.4.7	Intermediate transverse web stiffeners	93
8.4.8	End anchorage.....	120
8.4.9	Panels with openings	120
8.4.10	Web capacity and stiffeners design	120
8.4.11	Other types of stiffeners.....	123
8.4.12	Connections between web stiffeners and webs.....	123
8.4.13	Connections between web stiffeners and flanges	123
8.5	BUCKLING RESISTANCE MOMENT FOR SINGLE ANGLE MEMBERS.....	124
8.6	TENSION MEMBERS.....	124
8.6.1	Tension capacity	124
8.6.2	Members with eccentric connections	124
8.6.3	Single and double angle, channel and T-sections	124
8.6.4	Double angle, channel and T-sections with intermediate connections	125
8.7	COMPRESSION MEMBERS.....	125
8.7.1	Segment length.....	125
8.7.2	Effective length in general.....	125
8.7.3	Restraints.....	126
8.7.4	Slenderness	126
8.7.5	Compression resistance	126
8.7.6	Compressive strength.....	127
8.7.7	Eccentric connections.....	152
8.7.8	Simple construction.....	152
8.7.9	Effective length of sections in triangulated structures and trusses.....	152
8.8	TENSION MEMBERS UNDER COMBINED AXIAL FORCE AND MOMENTS.....	153
8.9	COMPRESSION MEMBERS UNDER COMBINED AXIAL FORCE AND MOMENTS.....	154
8.9.1	Cross-section capacity.....	154
8.9.2	Member buckling resistance	154
8.9.3	Member buckling resistance – (Alternative to 8.9.2)	157
8.10	TORSIONAL AND FLEXURAL-TORSIONAL BUCKLING OF COMPRESSION MEMBERS.....	161
8.11	PORTAL FRAMES.....	161
8.11.1	General	161
8.11.2	Elastic design.....	161
8.11.3	Plastic design.....	161
8.11.4	In-plane stability	161
8.11.5	Out-of-plane stability	164
8.12	LACED AND BATTENED STRUTS	168
8.12.1	Laced struts	168
8.12.2	Battened struts.....	168
Appendix 8.1	170
Appendix 8.2	171
Appendix 8.3	172

Appendix 8.4	173
9 CONNECTIONS.....	174
9.1 GENERAL.....	174
9.2 WELDED CONNECTIONS	175
9.2.1 Through-thickness tension.....	175
9.2.2 Types of welds	175
9.2.3 Weldability and electrodes.....	175
9.2.4 Welded connections to unstiffened flanges	175
9.2.5 Strength of welds	176
9.3 BOLTED CONNECTIONS	183
9.3.1 Bolt spacing	183
9.3.2 End and edge distances	183
9.3.3 Hole dimensions	184
9.3.4 Sectional area of connected parts	184
9.3.5 Block shear	186
9.3.6 Design strength of bolts under shear and bearing.....	186
9.3.7 Design strength of bolts in tension.....	190
9.3.8 Combined shear and tension.....	191
9.3.9 Bolts combined with welds.....	191
9.3.10 Pin connections.....	191
9.3.11 Connections for hollow sections of lattice girders.....	193
9.4 BASEPLATE AND ANCHOR CONSTRUCTION	193
9.4.1 Column base plates	193
9.4.2 Anchor bolts for base plates, wall plates and hangers	194
9.5 STEEL CASTINGS AND FORGINGS	196
10 COMPOSITE CONSTRUCTION	197
10.1 MATERIALS.....	197
10.1.1 Structural steel.....	197
10.1.2 Concrete.....	197
10.1.3 Reinforcement	198
10.1.4 Shear connectors	198
10.1.5 Profiled steel sheets	198
10.2 COMPOSITE BEAMS.....	199
10.2.1 General.....	199
10.2.2 Analysis of internal forces and moments.....	201
10.2.3 Establishment of composite cross-sections	203
10.2.4 Classification of composite cross-sections.....	204
10.2.5 Section capacities and properties of composite cross-sections.....	206
10.2.6 Ultimate limit state design.....	209
10.2.7 Serviceability limit state design	211
10.3 SHEAR CONNECTION	215
10.3.1 General.....	215
10.3.2 Design resistance of shear connectors	215
10.3.3 Provision of shear connectors	218
10.3.4 Detailing of shear connectors.....	220
10.3.5 Transverse reinforcement.....	221
10.4 COMPOSITE SLABS WITH PROFILED STEEL SHEET	225
10.4.1 General.....	225
10.4.2 Form of construction.....	225
10.4.3 Limit state design.....	226
10.4.4 Design of profiled steel sheets in construction stage	228
10.4.5 Design of composite slabs in composite stage	230
10.4.6 Detailing provisions	237
10.4.7 Constructional details	239
10.5 COMPOSITE COLUMNS	241
10.5.1 General.....	241
10.5.2 General method of design	242

10.5.3	<i>Simplified method of design</i>	243
10.5.4	<i>Shear connection and load introduction</i>	254
10.5.5	<i>Detailing provisions</i>	257
11	DESIGN OF COLD-FORMED STEEL OPEN SECTIONS, SHEET PROFILES, HOLLOW SECTIONS AND SHEET PILE SECTIONS	259
11.1	GENERAL DESIGN OF OPEN SECTIONS AND SHEET PROFILES	259
11.2	MATERIAL PROPERTIES	260
11.2.1	<i>Physical properties</i>	260
11.2.2	<i>Mechanical properties</i>	260
11.3	SECTION PROPERTIES	261
11.3.1	<i>Gross section properties</i>	261
11.3.2	<i>Effective section properties under tension</i>	262
11.3.3	<i>Effective section properties under compression and bending</i>	262
11.3.4	<i>Local buckling</i>	262
11.3.5	<i>Flange curling</i>	268
11.4	MEMBERS UNDER LATERAL LOADS	269
11.4.1	<i>General</i>	269
11.4.2	<i>Moment capacity</i>	269
11.4.3	<i>Shear capacity</i>	270
11.4.4	<i>Combined bending and shear</i>	271
11.4.5	<i>Web crushing capacity</i>	271
11.4.6	<i>Combined bending and web crushing</i>	275
11.4.7	<i>Lateral buckling</i>	276
11.4.8	<i>Calculation of deflection</i>	279
11.4.9	<i>Effects of torsion</i>	280
11.5	MEMBERS UNDER AXIAL LOADS	280
11.5.1	<i>Members under tension</i>	280
11.5.2	<i>Members under compression</i>	282
11.5.3	<i>Flexural buckling</i>	282
11.5.4	<i>Flexural-torsional buckling</i>	285
11.5.5	<i>Combined compression and bending</i>	286
11.6	CONNECTIONS	287
11.6.1	<i>General recommendations</i>	287
11.6.2	<i>Fastenings with bolts</i>	287
11.6.3	<i>Fastenings with screws and blind rivets</i>	289
11.6.4	<i>Interconnections in compound members</i>	290
11.6.5	<i>Bolted moment connections of compound members</i>	292
11.7	DESIGN FOR HOLLOW SECTIONS	294
11.7.1	<i>General design for hollow sections</i>	294
11.7.2	<i>Material Properties</i>	294
11.7.3	<i>Mechanical properties</i>	294
11.7.4	<i>Control of external corner profile</i>	294
11.7.5	<i>Welding at cold-formed zones</i>	295
11.7.6	<i>Cold formed section properties under loading</i>	295
11.7.7	<i>Calculation of deflection</i>	295
11.7.8	<i>Connections</i>	295
11.8	DESIGN FOR COLD-FORMED SHEET PILE SECTIONS	296
11.8.1	<i>General design for sheet pile sections</i>	296
11.8.2	<i>Material properties</i>	296
11.8.3	<i>Mechanical properties</i>	296
11.8.4	<i>Minimum inside radii for cold-formed sheet piles</i>	296
11.8.5	<i>Welding at cold-formed zones of cold-formed sheet piles</i>	297
11.8.6	<i>Cold-formed section properties under loading</i>	297
11.8.7	<i>Calculation of deflection</i>	297
12	FIRE RESISTANT DESIGN	298
12.1	DESIGN PRINCIPLES	298
12.1.1	<i>Basic requirements of fire resistance for a structure</i>	298

12.1.2	<i>Fire exposure</i>	298
12.1.3	<i>Fire limit states</i>	299
12.1.4	<i>Physical and mechanical properties at elevated temperatures</i>	299
12.1.5	<i>Material factors and load factors</i>	302
12.2	FIRE RESISTANCE DERIVED FROM STANDARD FIRE TESTS	303
12.2.1	<i>Fire resistances of structural members</i>	303
12.2.2	<i>Failure criteria for standard fire tests</i>	303
12.3	FIRE RESISTANCE DERIVED FROM LIMITING TEMPERATURE METHOD	304
12.4	Fire Resistance Derived from Performance-Based Design Methods	305
12.4.1	<i>Basis of analysis</i>	305
12.4.2	<i>Thermal response</i>	305
12.4.3	<i>Mechanical response</i>	305
12.4.4	<i>Validation of performance-based design methods</i>	306
12.4.5	<i>Simplified calculation methods</i>	306
12.5	Performance Requirements	306
13	PERFORMANCE-BASED DESIGN GUIDANCE FOR PARTICULAR TYPES OF STRUCTURES, INCLUDING GUIDANCE ON GENERAL MAINTENANCE OF STEEL STRUCTURES	307
13.1	HIGH-RISE BUILDINGS	307
13.1.1	<i>Structural systems for high-rise buildings</i>	307
13.1.2	<i>Stability issues for high-rise buildings</i>	307
13.1.3	<i>Considerations for particular details</i>	307
13.1.4	<i>Considerations for design against extreme events</i>	308
13.1.5	<i>Wind engineering for high-rise buildings</i>	308
13.2	GUIDANCE ON DESIGN OF TRANSMISSION TOWERS, MASTS AND CHIMNEYS	309
13.2.1	<i>Structural systems for transmission towers, masts and chimneys</i>	309
13.2.2	<i>Overall stability of towers, masts and chimneys</i>	309
13.2.3	<i>Particular details</i>	310
13.2.4	<i>Considerations for design against extreme events</i>	310
13.2.5	<i>Serviceability issues</i>	310
13.2.6	<i>Design issues for steel chimneys</i>	310
13.2.7	<i>Construction and corrosion protection of steel chimneys</i>	311
13.2.8	<i>Wind-excited vibrations of circular chimneys</i>	311
13.3	GLASS AND FAÇADE SUPPORTING STRUCTURES	312
13.3.1	<i>General</i>	312
13.3.2	<i>Deflection limit</i>	312
13.3.3	<i>Requirements</i>	312
13.3.4	<i>Loadings and actions</i>	313
13.3.5	<i>Tensioning structural systems</i>	313
13.4	TEMPORARY WORKS IN CONSTRUCTION	314
13.4.1	<i>Design philosophy</i>	314
13.4.2	<i>Second-order effects</i>	315
13.4.3	<i>Out-of-plumbness</i>	315
13.4.4	<i>Fitness tolerance</i>	315
13.4.5	<i>Member imperfections</i>	315
13.4.6	<i>Support settlements and flexible supports</i>	315
13.4.7	<i>Over-turning</i>	315
13.4.8	<i>Tolerance and clearance</i>	316
13.4.9	<i>New and used systems</i>	316
13.4.10	<i>Module testing</i>	316
13.5	LONG SPAN STRUCTURES	317
13.5.1	<i>Systems for long span structures</i>	317
13.5.2	<i>Overall stability of long span structures</i>	317
13.5.3	<i>Particular details</i>	317
13.5.4	<i>Considerations for design against extreme events</i>	317
13.5.5	<i>Serviceability issues</i>	317
13.6	FOOTBRIDGES	318
13.6.1	<i>Design philosophy</i>	318

13.6.2	Loads.....	318
13.6.3	Design for strength, deflection and fatigue.....	318
13.6.4	Vibration.....	320
13.6.5	Bearing design for footbridges	321
13.7	DESIGN LOADS FROM OVERHEAD RUNWAY CRANES, TOWER AND DERRICK CRANES AND MOBILE CRANES	321
13.7.1	Types and classifications of static cranes	321
13.7.2	Design issues for crane support structures.....	321
13.7.3	Loading from cranes.....	321
13.8	GUIDANCE ON MAINTENANCE OF STEEL STRUCTURES	323
13.8.1	General.....	323
13.8.2	Consideration of maintenance in the original design	323
13.8.3	Maintenance of existing structures.....	324
13.8.4	Health and safety issues on maintenance	324
14	FABRICATION AND ERECTION.....	325
14.1	DIMENSIONS AND TOLERANCES OF SECTIONS	325
14.2	WORKMANSHIP – GENERAL.....	325
14.2.1	Identification	325
14.2.2	Handling	325
14.2.3	Cutting	325
14.2.4	Shaping and forming	325
14.2.5	Holing	326
14.2.6	Assembly	327
14.2.7	Curving and straightening	327
14.2.8	Inspection	327
14.2.9	Storage	328
14.3	WORKMANSHIP – WELDING	328
14.3.1	General.....	328
14.3.2	Welder qualification	328
14.3.3	Welding procedure specifications.....	328
14.3.4	Assembly	329
14.3.5	Non-destructive testing of parent material.....	330
14.3.6	Non-destructive testing of welds (NDT).....	330
14.3.7	Shear stud welding.....	337
14.4	WORKMANSHIP – BOLTING	337
14.4.1	General.....	337
14.4.2	Ordinary bolted assemblies.....	337
14.4.3	Pre-loaded bolt assemblies	339
14.5	WORKMANSHIP – ERECTION.....	340
14.5.1	Erection method statement	340
14.5.2	Handling and storage	340
14.5.3	Damaged steelwork.....	341
14.5.4	Column base plates and slabs	341
14.5.5	Grouting.....	341
14.5.6	Stability	341
14.5.7	Alignment of part of the structure	341
14.5.8	Temperature effects.....	341
14.5.9	Site welding	341
14.5.10	Site bolting.....	341
14.6	PROTECTIVE TREATMENT	342
14.6.1	General.....	342
14.6.2	Materials.....	342
14.6.3	Surface preparation	342
14.6.4	Sprayed metal coatings	342
14.6.5	Hot-dip galvanizing.....	343
14.6.6	Paint treatments	343
14.6.7	Inspection and testing	343
15	ACCURACY OF FABRICATION AND ERECTION	344

15.1	GENERAL	344
15.2	PERMITTED DEVIATIONS IN THE CROSS SECTION OF ROLLED COMPONENTS	344
15.3	PERMITTED DEVIATIONS IN COMPONENTS AFTER FABRICATION	345
15.3.1	<i>Squareness of end not prepared for bearing</i>	345
15.3.2	<i>Squareness of ends prepared for bearing</i>	345
15.3.3	<i>Straightness of both axes or of individual webs of flanges</i>	345
15.3.4	<i>Length</i>	345
15.3.5	<i>Curved or cambered</i>	345
15.3.6	<i>Squareness at bearing</i>	345
15.4	PERMITTED DEVIATIONS FOR ELEMENTS OF FABRICATED MEMBERS	346
15.4.1	<i>Position of fittings</i>	346
15.4.2	<i>Position of holes</i>	346
15.4.3	<i>Punched holes</i>	346
15.4.4	<i>Shared or cropped edges of plates or angles</i>	346
15.4.5	<i>Flatness</i>	346
15.4.6	<i>Notches</i>	346
15.4.7	<i>Column base plates</i>	346
15.5	PERMITTED DEVIATIONS IN PLATE GIRDER SECTIONS	347
15.5.1	<i>Depth</i>	347
15.5.2	<i>Flange width</i>	347
15.5.3	<i>Squareness of section</i>	347
15.5.4	<i>Web eccentricity</i>	347
15.5.5	<i>Flanges</i>	347
15.5.6	<i>Top flange of crane girder</i>	347
15.5.7	<i>Web distortion</i>	347
15.5.8	<i>Cross section at bearings</i>	347
15.6	PERMITTED DEVIATIONS IN FABRICATED BOX SECTIONS	348
15.6.1	<i>Plate widths</i>	348
15.6.2	<i>Squareness</i>	348
15.6.3	<i>Plate distortion</i>	348
15.7	PERMITTED DEVIATIONS OF STIFFENERS	348
15.7.1	<i>Web stiffeners</i>	348
15.7.2	<i>Web stiffeners</i>	348
15.8	PERMITTED DEVIATIONS OF LATTICE COMPONENTS	349
15.8.1	<i>Panel length</i>	349
15.8.2	<i>Cumulative length of panels</i>	349
15.8.3	<i>Joint eccentricity</i>	349
15.8.4	<i>Overall cross section</i>	349
15.8.5	<i>Tubular lattice girders</i>	349
15.9	PERMITTED DEVIATIONS OF COLD FORMED SECTIONS	350
15.9.1	<i>Position of measurement</i>	350
15.9.2	<i>Thickness</i>	350
15.9.3	<i>External dimensions</i>	350
15.9.4	<i>Length</i>	350
15.9.5	<i>Angular tolerance</i>	350
15.9.6	<i>Straightness</i>	350
15.9.7	<i>Angle of twist</i>	351
15.9.8	<i>Compound members</i>	351
15.9.9	<i>Flatness</i>	351
15.10	PERMITTED DEVIATIONS FOR FOUNDATIONS, WALLS AND HOLDING DOWN BOLTS	352
15.10.1	<i>Foundation level</i>	352
15.10.2	<i>Vertical wall</i>	352
15.10.3	<i>Pre-set foundation bolt or bolt groups when prepared for adjustment</i>	352
15.10.4	<i>Pre-set foundation bolt or bolt groups when not prepared for adjustment</i>	352
15.10.5	<i>Pre-set wall bolt or bolt groups when not prepared for adjustment</i>	352
15.10.6	<i>Embedded steel anchor plate</i>	352
15.11	APPLICATION OF PERMITTED DEVIATION FOR ERECTED COMPONENTS	353
15.12	PERMITTED DEVIATIONS OF ERECTED COMPONENTS AND STRUCTURES	353

15.12.1	Position of columns at base	353
15.12.2	Overall plan dimensions	353
15.12.3	Single storey columns plumb	353
15.12.4	Multi-storey columns plumb.....	353
15.12.5	Alignment of columns at splice	354
15.12.6	Location of column splice	354
15.12.7	Gap between bearing surfaces	354
15.12.8	Alignment of adjacent perimeter columns	354
15.12.9	Beam level	354
15.12.10	Level at each end of same beam	354
15.12.11	Level of adjacent beams within a distance of 5 metres.....	354
15.12.12	Level of beams at adjacent floors.....	355
15.12.13	Beam alignment.....	355
15.12.14	Position in plan of members	355
15.12.15	Crane gantry column plumb	355
15.12.16	Crane gantries gauge of rail tracks	355
15.12.17	Joints in gantry crane rails – rail surface	355
15.12.18	Joints in gantry crane rails – rail edge.....	356
15.12.19	Profile steel floor decking	356
15.12.20	Thickness of bedding.....	356
15.12.21	Position on bearing.....	356
16	LOADING TESTS	357
16.1	GENERAL.....	357
16.1.1	Scope	357
16.1.2	Requirement for testing	357
16.1.3	Recommendations for conduct of tests	357
16.2	PROOF, STRENGTH AND FAILURE TESTS	358
16.2.1	Proof and strength tests	358
16.2.2	Failure test.....	359
16.3	TEST CONDITIONS, METHODS AND PROCEDURES	359
16.3.1	Test conditions.....	359
16.3.2	Loading and unloading	359
16.3.3	Measurements	360
16.3.4	Material properties.....	360
16.3.5	Relative strength coefficient	360
16.3.6	Quality control of load testing	360
16.3.7	Contents of test report	360
16.4	TESTING OF COMPOSITE SLABS.....	361
16.4.1	General.....	361
16.4.2	Specific tests	361
16.4.3	Parametric tests.....	364
17	GUIDANCE FOR EVALUATION AND MODIFICATION OF EXISTING STRUCTURES	367
17.1	GENERAL APPROACH	367
17.2	STRUCTURAL ASSESSMENT SURVEY	367
17.2.1	Original materials.....	367
17.2.2	Appraisal report	368
17.3	DESIGN AND ANALYSIS ISSUES.....	368
17.3.1	Structural appraisal analysis and design check	368
17.3.2	Overall stability of existing and new structure	368
17.3.3	Details for connection of new to old structure	368
17.3.4	Upgrading of original structure	368
17.3.5	Considerations for design against extreme events (fire, accident, terrorism)	369
17.3.6	Serviceability issues	369
17.4	LOAD TESTS	369

ANNEX A	REFERENCES	370
A1	ACCEPTABLE STANDARDS AND REFERENCES	370
A1.1	<i>Steel materials</i>	370
A1.2	<i>Castings and forgings</i>	373
A1.3	<i>Bolts</i>	374
A1.4	<i>Welding</i>	378
A1.5	<i>Materials for composite design</i>	382
A1.6	<i>Shear studs</i>	382
A1.7	<i>Cold-formed steel materials</i>	383
A1.8	<i>Dimensions and tolerances of sections</i>	384
A1.9	<i>Protective treatment</i>	385
A1.10	<i>Other acceptable references</i>	386
A2	INFORMATIVE REFERENCES	386
A2.1	<i>Practice Notes for Authorized Persons and Registered Structural Engineers</i>	386
A2.2	<i>The Steel Construction Institute, UK</i>	386
A2.3	<i>UK and European Standards</i>	387
A2.4	<i>Australian Standards</i>	388
A2.5	<i>General references</i>	388
ANNEX B	RELATIVE STRENGTH COEFFICIENT	389
B1	GENERAL	389
B2	PREDETERMINATION OF THE TEST LOAD FOR A STRENGTH TEST	389
B3	PROCESSING THE RESULTS OF A FAILURE TEST	389
ANNEX C	TYPICAL WELDING SYMBOLS	391
ANNEX D	NOTES ON TESTING TO ESTABLISH STEEL CLASS AND ESSENTIAL OF SOME PRODUCT STANDARDS	395
D1	TESTING TO ESTABLISH STEEL CLASS	395
D1.1	<i>Essential requirements</i>	395
D1.2	<i>Quality control of testing</i>	397
D2	ABSTRACT OF ESSENTIAL REQUIREMENTS FOR BOLTS	398

List of Figures

Figure 2.1-	Typical S-N curves for welded steel	22
Figure 2.2-	Examples of tying columns of a building	24
Figure 2.3-	Examples of general tying of a building	25
Figure 6.1-	Column effective length length, P- Δ and P- δ moments	54
Figure 6.2-	Sway and non-sway buckling modes	56
Figure 6.3-	Notional horizontal force for out-of-plumbness	57
Figure 6.4-	Restraint coefficients for sub-frame	59
Figure 6.5a-	Effective length factor (L_E/L) for sway frames	60
Figure 6.5b-	Effective length factor (L_E/L) for non-sway frames.....	60
Figure 6.6-	Connection behaviour	64
Figure 7.1-	Dimensions of compression elements	67
Figure 7.2-	Stress ratio for semi-compact web.....	70
Figure 7.3-	Dimensions of compound flanges.....	71
Figure 7.4-	Stress redistribution of singly symmetric slender cross-section subjected to compression	74
Figure 7.5-	Doubly symmetric slender cross-section subjected to compression	75
Figure 7.6-	Doubly symmetric slender cross-section subjected to bending.....	75
Figure 8.1-	Standard castellated beams	80
Figure 8.2-	Restraint at end of a cantilever to reduce its effective length	80
Figure 8.3-	Stiff bearing length	120
Figure 8.4-	Rolled I- or H-sections with welded flange plates	127
Figure 8.5-	Geometry of portal frames	162
Figure 8.6-	Example of using fly brace for column and rafter	165
Figure 8.7-	Haunch restraints.....	167
Figure 9.1-	Effective breadth of an unstiffened Tee-joint.....	176
Figure 9.2-	Geometry of fillet welds.....	176
Figure 9.3-	End return of welds	178
Figure 9.4-	Fillet welds - directional method	179
Figure 9.5-	Partial penetration butt welds	182
Figure 9.6-	Single and double sides of penetration welds	182
Figure 9.7-	Staggered holes	185
Figure 9.8-	Angles with holes in legs.....	185
Figure 9.9-	Block shear and effective shear area	186
Figure 9.10-	Lap length of a splice	188
Figure 9.11-	Prying force	190
Figure 9.12-	Pin-ended tension member.....	191
Figure 9.13-	Bending action in pinned connection	192
Figure 9.14-	Typical base plates	194
Figure 10.1-	Typical composite beams	199
Figure 10.2-	Value of L_z for continuous beams	204
Figure 10.3-	Determination of web stress ratio r	206
Figure 10.4-	Reduced section	208
Figure 10.5-	Lateral buckling of bottom flanges in continuous composite beams	211
Figure 10.6-	Breadth of concrete rib, br	217
Figure 10.7-	Minimum dimensions	221
Figure 10.8-	Transverse shear surfaces	222
Figure 10.9-	Edge beam details	224
Figure 10.10-	Typical profiled steel sheets	226
Figure 10.11-	Arrangement of construction loads	229
Figure 10.12-	Mode of failure of a composite slab	232
Figure 10.13-	Stress blocks for moment capacity	233
Figure 10.14-	Critical perimeter for shear	235
Figure 10.15-	Sheet and slab dimensions.....	238

Figure 10.16-	Bearing requirements.....	239
Figure 10.17-	Typical cross-sections of doubly symmetrical composite columns.....	241
Figure 10.18-	Interaction curves and corresponding stress distributions.....	251
Figure 10.19-	Interaction curves for compression and uni-axial bending	252
Figure 10.20-	Verification for combined compression and bi-axial bending.....	254
Figure 10.21-	Additional frictional forces in composite columns by use of headed studs.....	255
Figure 10.22-	Arrangement of stirrups	256
Figure 11.1-	Typical cold-formed steel open sections and sheet profiles	259
Figure 11.2a-	Idealized section for C and Z section.....	261
Figure 11.2b-	Idealized section for sheet profile	261
Figure 11.3-	Effective width for stiffened and unstiffened elements.....	263
Figure 11.4-	Simple lip edge stiffener.....	264
Figure 11.5-	Calculation of effective widths allowing for corner radii	265
Figure 11.6-	Stress distributions over effective portions of web.....	266
Figure 11.7-	Flange curling	268
Figure 11.8-	Determination of moment capacity	270
Figure 11.9-	Examples of cross-sections	274
Figure 11.10-	Restraint condition for lateral buckling.....	277
Figure 11.11-	Nomenclature for staggered holes with example.....	281
Figure 11.12-	Compression of singly symmetrical section.....	283
Figure 11.13-	Connection forces in back-to-back members	292
Figure 11.14-	Typical bolted moment connection	292
Figure 11.15-	Internal forces of a bolted moment connection	293
Figure 13.1-	Values of geometric imperfections: (a) & (b) out-of-plumbness, (c) member imperfection and (d) eccentricity.....	316
Figure 13.2-	Vertical deflections to be considered	319
Figure 14.1-	Combined thickness.....	331
Figure 16.1-	Test details	362
Figure 16.2-	Shear bond failure.....	366

List of Tables

Table 2.1-	Limit states	19
Table 2.2-	Summary of lateral forces to be considered	29
Table 3.1-	Strength grade summary table.....	31
Table 3.2-	Design strength p_y for steels supplied in accordance with BS EN standards (plates, hot rolled sections, hot finished and cold formed hollow sections, cold formed sections and profiled sheets)	33
Table 3.3-	Design strength p_y for steels supplied in accordance with Chinese standard GB50017 (plates, hot rolled sections, hot finished and cold formed hollow sections, cold formed sections and profiled sheets)	34
Table 3.4-	Design strength p_y for North American steel supplied to ASTM Standards (plates, hot rolled sections, hot finished and cold formed hollow sections, cold formed sections and profiled sheets)	35
Table 3.5-	Design strength p_y for steels supplied in accordance with Australian standards (plates, hot rolled sections, hot finished and cold formed hollow sections, cold formed sections and profiled sheets)	35
Table 3.6-	Design strength p_y for Japanese JIS SN Steel (rolled steel for building products) to JIS G 3136 supplied in accordance with JIS standards (plates, hot rolled sections, hot finished and cold formed hollow sections, cold formed sections and profiled sheets)	36
Table 3.7-	Maximum permissible values of element thickness t in mm.....	39
Table 3.8-	Yield and tensile strengths for steels supplied in accordance with various national standards.....	42
Table 4.1-	Material factors γ_{m1} and γ_{m2} for various classes of steels	45
Table 4.2-	Partial load factors and combinations for normal condition design	45
Table 4.3-	Partial load factors and combinations for extreme events	46
Table 4.4-	Summary of partial load factors for ultimate limit state	47
Table 5.1-	Deflection limits	48
Table 5.2-	Exposure conditions.....	51
Table 5.3-	Types of protective system and typical application guide	52
Table 6.1-	Values of member initial bow imperfection used in design	58
Table 6.2-	Stiffness of beam for effective length determination in continuous structures.....	61
Table 7.1-	Limiting width-to-thickness ratios for sections other than CHS and RHS.....	68
Table 7.2-	Limiting width-to-thickness ratios for CHS and RHS	69
Table 8.1-	Effective length of cantilever without intermediate restraints.....	82
Table 8.2-	Limiting value of L_E/r_y for RHS	83
Table 8.3a-	Bending strength p_b (N/mm ²) for rolled sections.....	85
Table 8.3b-	Bending strength p_b (N/mm ²) for welded sections	86
Table 8.3c-	Bending strength p_b (N/mm ²) for other steel source	88
Table 8.4a-	Equivalent uniform moment factor m_{LT} for lateral-torsional buckling of beams under end moments and typical loads	90
Table 8.4b-	Equivalent uniform moment factor m_{LT} for lateral-torsional buckling of beams under non-typical loads	91
Table 8.5-	Shear buckling strength q_w (N/mm ²) of a web	96
Table 8.6-	Effective length of idealized columns.....	126
Table 8.7-	Designation of buckling curves for different section types.....	128
Table 8.8-	Design strength p_c of compression members	129
Table 8.9-	Moment equivalent factor m for flexural buckling	156
Table 8.10-	Interaction factors for combined axial compression and bending	158
Table 8.11-	Interaction factors k_{ij} for members susceptible to torsional deformations	159

Table 8.12-	Equivalent uniform moment factors, C_m in Tables 8.10 and 8.11	160
Table 9.1-	Minimum leg length of a fillet weld.....	177
Table 9.2a-	Design strength of fillet welds p_w for BS-EN and American Welding Society (AWS) Standards	178
Table 9.2b-	Design strength of fillet welds p_w for GB or other Standards.....	178
Table 9.3-	Minimum end and edge distances of holes (for standard holes)	183
Table 9.4-	Nominal hole dimensions.....	184
Table 9.5-	Design shear strength of bolts	187
Table 9.6-	Design bearing strength of bolts	187
Table 9.7-	Slip factors for preloaded bolts	189
Table 9.8-	Design tension strength of bolts	190
Table 10.1-	Compressive strength and short-term elastic modulus for various concrete grades	197
Table 10.2-	Simplified moment coefficients	201
Table 10.3-	Maximum redistribution of support moments for elastic global analysis	202
Table 10.4-	Modular ratios for normal weight concrete.....	204
Table 10.5-	Limiting width to thickness ratios for flanges and webs in composite sections.....	205
Table 10.6-	Limiting width to thickness ratios for semi-compact webs	205
Table 10.7-	Characteristic resistance P_k of headed shear studs in normal weight concrete	215
Table 10.8-	Upper limit for k	217
Table 10.9-	Nominal minimum slab thickness of concrete – trapezoidal sheets	228
Table 10.10-	Nominal minimum slab thickness of concrete – re-entrant sheets	228
Table 10.11-	Maximum values on geometric ratios	243
Table 10.12-	Factors β for the determination of moments to second order theory.....	244
Table 10.13-	Buckling curves and member imperfections for composite columns.....	247
Table 10.14-	Buckling strength reduction factors of composite columns.....	248
Table 10.15-	Design shear strength τ	257
Table 10.16-	Design shear strength τ_{Rd} for complete concrete encased steel sections.....	257
Table 11.1-	Basis for calculation of section properties	261
Table 11.2a-	Shapes having single thickness webs	272
Table 11.2b-	I-beams and beams with restraint against web rotation	273
Table 11.3-	Design strength of bolts in clearance holes	288
Table 11.4-	External corner profile.....	294
Table 11.5-	Conditions for welding cold-formed areas and adjacent materials	295
Table 11.6-	Minimum inside radii for JC steel grade.....	296
Table 11.7-	Minimum inside radii for MC / NC steel grades	297
Table 12.1-	Typical physical properties of steel and concrete at elevated temperatures	300
Table 12.2a-	Strength reduction factors for hot rolled steels at elevated temperatures	300
Table 12.2b-	Strength reduction factors for cold-formed steels at elevated temperatures	300
Table 12.2c-	Strength reduction factors for normal weight concrete at elevated temperatures.....	301
Table 12.2d-	Strength reduction factors for cold worked reinforcing bars at elevated temperatures.....	301
Table 12.2e-	Strength reduction factors for hot rolled reinforcing bars at elevated temperatures.....	301
Table 12.3-	Strength reduction factors for bolts and welds at elevated temperatures.....	302
Table 12.4-	Material factors for fire limit state.....	302
Table 12.5-	Load factors for fire limit state.....	302
Table 13.1-	Recommended limiting values for vertical deflections	319
Table 13.2-	Partial safety factor for fatigue strength	320
Table 13.3-	For normal condition design but with crane load	322

Table 14.1-	Tolerances on hole diameters	326
Table 14.2a-	Requirements for submission of welding procedure specifications	328
Table 14.2b-	Illustrative hold times	331
Table 14.3a-	Scope and frequency of inspection (NDT).....	332
Table 14.3b-	Acceptance criteria for welds in steel structures.....	334
Table 14.3c-	Definition of zones and weld orientation	335
Table 14.3d-	Characteristic defects of welds in steel structures.....	336
Table 14.4-	Matching bolt, nut and washer standards for ordinary bolts	338
Table 14.5-	Recommended tightening torques and approximate bolt tensions for ISO grade 8.8 bolts (Assumes bolts oiled).....	339
Table 15.1-	Permitted deviations for the width of internal elements	350
Table 15.2-	Permitted deviations for the width of outstand elements	350
Table D1a-	Essential performance requirements for hot rolled and hot finished structural steel and cold formed steel	396
Table D1b-	Essential performance requirements for cold formed thin gauge steel	396
Table D2-	Minimum material property requirements for various high strength steels	397
Table D3-	Essential performance requirements for bolts	398
Table D4-	Various normally used bolt strengths	399

1 GENERAL

1.1 SCOPE

The Code of Practice for the Structural Use of Steel (Limit State Approach), hereinafter referred to as “the Code”, gives recommendations for the design of structural steel buildings and allied structures not specifically covered by other standards.

It does not cover all aspects of special types of steel structure such as rail or road bridges, articulated access walkways, nuclear power stations or pressure vessels. Nor does it cover structures made from fibre composites.

The Code is not intended to be used for the design of bridges, which in Hong Kong would normally be designed to the Structures Design Manual for Highways and Railways and relevant codes. However, it may be used for the design of footbridges such as those connecting buildings. In such a case, reference should also be made to the Structures Design Manual for Highways and Railways and other acceptable references.

Section 1 contains general requirements including the scope of the Code.

Section 2 describes the principles of the limit state approach used in the Code.

Section 3 covers the use of hot rolled steel sections, flats, plates, hot finished and cold formed structural hollow sections and cold formed open sections and sheet profiles conforming to acceptable international steel product standards from Australia, China, Japan, United States of America and British versions of European Union standards (i.e. European standards with British National Application Documents). These standards are listed in Annex A1. In addition to covering normally available steel with yield stresses in the range from 190 N/mm² to 460 N/mm², this section gives design recommendations on the use of high strength steel, defined as steel with yield stresses between 460 N/mm² and 690 N/mm², and uncertified steel, whereby the design strength is limited to 170 N/mm². The use of steels with yield strengths greater than 690 N/mm² is not covered in the Code.

Where other structural materials are used in association with structural steelwork, they should conform to the Hong Kong or other equivalent standards. Particular examples are, but are not limited to, Concrete, Cement Grout, Reinforcement, Stainless Steel and Aluminium.

Section 4 gives design recommendations for partial load factors in normal and extreme event load cases.

Section 5 contains particular requirements and guidance for deflection control and structural dynamics including serviceability criteria for wind induced vibration of tall buildings. The section also covers durability and protection against corrosion attack.

Recommendations for the application of “second order” methods of global analysis are provided in **Section 6**.

Design recommendations in **Sections 7, 8 and 9** cover the use of hot rolled steel sections, flats, plates, hot finished and cold formed structural hollow sections with steel grades up to yield stresses of 460 N/mm² and allow use of yield stresses between 460 N/mm² and 690 N/mm² subject to restrictions.

Section 10 covers the design of steel and concrete elements acting compositely, with concrete up to a design cube strength of 60 N/mm² and steel up to a design yield strength of 460 N/mm². The use of lightweight concrete is not covered in the Code.

Section 11 provides simplified guidance on the use of cold-formed thin gauge steel open sections and sheet profiles with a design yield strength up to 550 N/mm². The use of cold formed hollow sections and sheet pile sections are incorporated in this section.

Design recommendations for Structural Fire Engineering of steels up to yield stresses of 460 N/mm² are given in **Section 12**.

Section 13 provides performance-based design recommendations for various types of structure. These comprise high rise buildings, transmission towers, masts and chimneys, glass supporting structures, temporary works in construction, long span structures and

footbridges. This section also contains guidance on loading from cranes and on maintenance of steel structures.

Sections 14 and 15 contain detailed guidance on fabrication and erection requirements.

The procedures for loading tests given in **Section 16** are intended only for steel structures within the scope of this Code.

Design recommendations for the evaluation and modification of existing steel structures are given in **Section 17**.

Annex A contains a list of the acceptable standards and updated references to the Building Authority for use in conjunction with the Code. Other standards or data in technical references may be used in lieu of the Code only if they can achieve a performance equivalent to the acceptable standards given in **Annex A**.

Annex B contains a method of calculating the relative strength coefficient for use in assessing the results of loading tests.

Annex C contains drawings of typical welding symbols.

Annex D contains testing to establish steel classes, essential requirements of product specifications for steel materials and bolts.

1.2 DESIGN PHILOSOPHY

1.2.1 Aims of structural design

The aims of structural design are to provide a structure with the following attributes:

- a) Overall Stability against overturning, sliding, uplift or global buckling under the design loads.
- b) Strength against collapse under normal loads and imposed deformations and during construction with an acceptable level of safety.
- c) Integrity, ductility and robustness against abnormal loads from extreme events without suffering disproportionate collapse, in which alternative load paths may be established.
- d) Fire resistance.
- e) Serviceability under all normal loads and imposed deformations.
- f) Durability.
- g) Maintainability during its design working life.
- h) Buildability.
- i) Economy: The structure should fulfill the above requirements in an economic manner.

1.2.2 Design responsibility and assumptions

One appropriately qualified and experienced professional engineer, the **Responsible Engineer**, should be responsible for the design of the overall conceptual structural system including the primary vertical and lateral load paths by means of which the vertical and lateral loads are carried safely to the ground, the overall stability and the robustness and integrity to prevent disproportionate collapse. Compatibility between these systems should be ensured.

The detailed design should be carried out by qualified and competent engineers under the supervision of the Responsible Engineer.

1.2.3 **Structural system, integrity and robustness**

1.2.3.1 *Structural system*

An overall three dimensional structural system shall be designed which defines the means by which the primary vertical and lateral loads are carried safely to the ground.

1.2.3.2 *Robustness, integrity and key elements*

The overall structural system should be designed to be robust and able to resist disproportionate collapse. Structural integrity should be provided by tying all elements together horizontally and vertically. Particular elements of the structure that have a critical influence on overall strength or stability of the structures should be identified as key elements. These elements should be designed to resist abnormal forces arising from extreme events. The other elements should be designed to survive the removal of a non-key element by establishing alternative load paths.

1.2.4 **Overall stability**

Overall stability of the structure in approximately orthogonal directions shall be provided by moment resisting frame action, by bracing or by a combination of both. The bracing systems may be provided by cores. The need for diaphragm action in floors to transmit lateral forces to vertical elements shall be considered.

1.2.5 **Limit State Design**

Limit state design considers the functional limits of strength, stability and serviceability of both single structural elements and the structure as a whole. See clause 2.2.

Ultimate limit states consider the safety of the whole or part of the structure. Examples of ultimate limit states are **strength** including yielding, rupture, buckling and forming a mechanism, **stability** against overturning, sliding, uplift and overall lateral or torsional sway buckling, **fire** leading to deterioration of mechanical properties at elevated temperatures and thermal actions, **fracture** caused by brittle material behaviour or by fatigue.

Serviceability limit states correspond to limits beyond which specified in-service criteria are no longer met. Examples are **deflection**, wind-induced **vibration**, human-induced **vibration** and **durability**.

1.2.6 **Economy**

Whilst the ultimate limit state capacities and resistances given in the Code are to be regarded as limiting values, the purpose of a design should be to reach these limits in as many parts of the structure as possible, to adopt a layout such that maximum structural efficiency is attained and to rationalize the steel member sizes and details in order to obtain the optimum combination of materials and workmanship, consistent with the overall requirements of the structure.

1.2.7 **Design working life**

The Code assumes a design working life of 50 years. This is considered to be appropriate for normal buildings and other common structures. The design working life should be clearly identified in the design documentation.

Where a design working life of more than 50 years is required, particular requirements on design and on quality control of materials and construction will need special consideration and specification.

1.3 REFERENCES

Lists of acceptable standards and references for use in conjunction with the Code are given in Annex A1. Informative references in Annex A2 provide more detailed guidance on particular aspects of design. Annex D contains essentials of some standards where appropriate. The essentials are for guidance and ease of use of the Code. Compliance with the acceptable standards and references takes precedence over guidance given in the essentials.

The Code will accept materials that are hot rolled steel plates and sections, cold formed steel plates and sections, forgings, castings, bolts, shear studs, welding consumables to acceptable international steel product standards from five regions / countries. These are Australia, China, Japan, United States of America and British versions of European Union standards.

In order to provide a single consistent set of standards for steel materials and products, their workmanship and quality assurance procedures, such standards and procedures shall generally be defined in the Code or as given in the acceptable references in Annex A1.

In particular, references on welding, welding procedure specifications, welder qualification and testing of welds are based on current local practice. These references are given in Annex A1.4.

1.4 GLOSSARY OF TERMS AND DEFINITIONS

In the Code, the following general terms and definitions apply. They are organized in generic groups. Additional definitions of more specialized terms are given in relevant sections.

1.4.1 General definitions

acceptable standards

Standards and references acceptable to the Building Authority (BA) as given in Annex A

acceptable Quality Assurance system

a quality assurance system which is acceptable to the BA and which conforms to the requirements in ISO 9001 and Hong Kong Accreditation Service

BA

The Building Authority

B(C)R

The Building (Construction) Regulations under the Buildings Ordinance

building height

the height from assumed structural base level (where vertical and lateral loads are transmitted to the ground) to the floor of topmost storey of the structure (i.e. excluding architectural features)

Code

Code of Practice for the Structural Use of Steel 2011

dead load

characteristic dead load G_k : - any permanent structural or non-structural loads that remain throughout the service life of a structure as stated in the Building (Construction) Regulations

imposed load

characteristic imposed load Q_k : - the applied load, with the exception of dead and wind loads, likely to arise during its service life in structure as given in the Building (Construction) Regulations

wind load

characteristic wind load W_k : - the applied load as calculated in accordance with The Code of Practice on Wind Effects

pattern load

loads arranged to give the most severe effect on a particular element

factored load

characteristic or specified load multiplied by the relevant partial factor

dynamic load

part of an imposed load resulting from motion

design strength

the notional yield strength of the material used in design, obtained by applying partial factors to the specified characteristic material strength

capacity

limit of force or moment that can be resisted without failure due to yielding or rupture

CS2

Hong Kong Construction Standard 2

empirical method

simplified method of design justified by experience or by tests

GEO technical guidance documents

Geotechnical Manual, Geoguides, Geospecs, Publications, Reports and Technical Guidance Notes published by the Geotechnical Engineering Office of Civil Engineering and Development Department of the Hong Kong SAR Government

HKAS

Hong Kong Accreditation Service

HKCC

Code of Practice for Structural Use of Concrete

HKPCC

Code of Practice for Precast Concrete Construction

HKWC

Code of Practice on Wind Effects in Hong Kong

HOKLAS

Hong Kong Laboratory Accreditation Scheme

PNAP

Practice Notes for Authorized Persons, Registered Structural Engineers and Registered Geotechnical Engineers as issued from time to time by the Building Authority

1.4.2 Structural element definitions**beam**

a member predominantly subject to bending

cantilever

a beam that is fixed at one end and free to deflect at the other

column

a vertical member predominantly carrying axial force and possibly moments

mega column

very large column, typically used for outrigger or externally braced tube in high rise structures

strut

member carrying predominantly axial compressive force

foundation

part of a structure that distributes load directly to the ground

portal frame

a single storey frame with rigid moment-resisting joints

sub-frame

part of a larger frame

segment

a portion of the length of a member, between adjacent points that are laterally restrained

transverse

direction perpendicular to the stronger of the rectangular axes of the member

torsional restraint

restraint that prevents rotation of a member about its longitudinal axis

1.4.3 Structural behaviour definitions

buckling resistance

limit of force or moment that a member can withstand without buckling

effective length for a beam

length between adjacent restraints against lateral-torsional buckling, multiplied by a factor that allows for the effect of the actual restraint conditions compared to a simple beam with torsional end restraint

effective length for a compression member

length between adjacent lateral restraints against buckling about a given axis, multiplied by a factor that allows for the effect of the actual restraint conditions compared to pinned ends

elastic analysis

structural analysis that assumes no redistribution of moments in a continuous member or frame due to plastic hinge rotation

elastic critical load

load at which perfect element or structure becomes elastically unstable

global imperfection

geometric out-of-plumbness of structural system

global stability

stability of overall structure against buckling, overturning, uplift and sliding

instability

inability to carry further load due to vanishing stiffness

lateral restraint for a beam

restraint that prevents lateral movement of the compression flange

lateral restraint for a compression member

restraint that prevents lateral movement of the member in a given plane

local stability

stability of element or part of element against buckling

member imperfection

inherent out-of-straightness of structural member

plastic analysis

structural analysis that allows for redistribution of moments in a continuous member or frame due to plastic hinge rotation

plastic load factor

the ratio by which each of the factored loads would have to be increased to produce a plastic hinge mechanism

plastic moment

moment capacity allowing for redistribution of stress within a cross-section

second order analysis

analysis of structures involving the tracing of the equilibrium or the load versus deflection path up to the formation of first plastic hinge with consideration of initial member imperfections

slenderness

the effective length divided by the radius of gyration

stability

resistance to failure by buckling or loss of static equilibrium

1.4.4 Material behaviour definitions**brittle fracture**

brittle failure of steel at low temperature

ductility

ability of a material to undergo plastic deformations

fatigue

damage to a structural member caused by repeated application of stresses that are insufficient to cause failure by a single application

strength

resistance to failure by yielding or buckling

1.4.5 Section type definitions**built-up**

constructed by interconnecting more than one rolled section to form a single member

compact cross-section

a cross-section that can develop its plastic moment capacity, but in which local buckling prevents rotation at constant moment

compound section

sections, or plates and sections, interconnected to form a single member

H-section

section with a central web and two flanges, that has an overall depth not greater than 1.2 times its overall width

hybrid section

section with a web or webs of lower strength grade than that of the flanges

I-section

section with a central web and two flanges, that has an overall depth greater than 1.2 times its overall width

plastic cross-section

a cross-section that can develop a plastic hinge with sufficient rotation capacity to allow redistribution of bending moments within a continuous member or frame

semi-compact cross-section

a cross-section that can develop its elastic capacity in compression or bending, but in which local buckling prevents development of its plastic moment capacity

slender cross-section

a cross-section in which local buckling prevents development of its elastic capacity in compression and/or bending

welded section

cross-section fabricated from plates by welding

1.4.6 Connection definitions

connection

location where a member is fixed to a supporting member or other support, including the bolts, welds and other material used to transfer loads

edge distance

distance from the centre of a bolt hole to the nearest edge of an element, measured perpendicular to the direction in which the bolt bears

end distance

distance from the centre of a bolt hole to the edge of an element, measured parallel to the direction in which the bolt bears

friction grip connection

a bolted connection that relies on friction to transmit shear between components

joint

element of a structure that connects members together and enables forces and moments to be transmitted between them

notched end

connected end of a member with one or both flanges cut away locally

preloaded bolt

bolt tightened to a specified initial tension, sometimes called High Strength Friction Grip or HSFG bolt

rotation capacity

the angle through which a joint can rotate without failing

rotational stiffness

the moment required to produce unit rotation in a joint

slip resistance

limit of shear that can be applied before slip occurs in a friction grip connection

1.5 MAJOR SYMBOLS

A	Cross-sectional area of the beam
A_c	Cross-sectional area of the concrete section of the column or Net sectional area of the connected leg
A_{cv}	Mean cross-sectional area, per unit length of the beam of the concrete shear surface under consideration
A_e	Effective net area of a section or a sheet profile (for tension or compression)
A_{eff}	Effective cross-sectional area (for tension or compression)
A_g	Gross cross-sectional area
A_n	Net area
A_{net}	Effective net area of a section or a sheet profile
A_p	Cross-sectional area of the profiled steel sheeting
A_s	Shear area of a bolt
A_{sv}	Cross-sectional area per unit length of the beam of the combined top and bottom reinforcement crossing the shear surface
A_t	Tensile stress area of a bolt
A_u	Gross sectional area of the unconnected leg or legs
A_v	Shear area of a member
$A_{v,eff}$	Effective shear area
$A_{v,net}$	Net shear area after deducting bolt holes
A_l	Loaded area under the gusset plate

B	Width or breadth of section
B_c	Width of the compression flange
B_e	Total effective breadth of the concrete flange
B_f	Width of the flange for flange curling
B_s	Width of the composite slab
B_t	Width of the tension flange
C	Distance from the end of the section to the load or the reaction
C_w	Warping constant for the cross-section
D	Depth of section or Diameter of section or Diameter of hole
D_p	Overall depth of the profiled steel sheet
D_s	Depth of concrete flange
E	Modulus of elasticity
E_{cm}	Short-term elastic modulus of the normal weight concrete
$(EI)_e$	Effective flexural stiffness
F	Local concentrated load or reaction between the points of interconnection under consideration
F_L	Longitudinal shear parallel to axis of the weld
F_T	Resultant transverse force perpendicular to axis of the weld
F_N	Notional horizontal force
F_V	Factored dead plus live loads on and above the floor considered
F_w	Concentrated force
F_a	End anchorage force per shear connector or Compression axial force
F_b	Beam longitudinal shear force per shear connector
F_c	Axial compression
F_n	Longitudinal compressive force in the concrete slab at the point of maximum negative moment
F_p	Longitudinal compressive force in the concrete slab at the point of maximum positive moment
F_t	Applied tensile load
F_{tot}	Total applied tension in bolt
F_{nom}	Nominal tension capacity of the bolt
G	Shear modulus
G_k	Characteristic dead load
H	Warping constant of section
I	Second moment of area of the structural steel cross-section about the critical axis
I_{CA}	Second moment of area of the composite slab about its centroidal axis
I_{CS}	Second moment of area for the cracked section
I_{GS}	Second moment of area for the gross section
I_c	Second moment of area of the un-cracked concrete section
I_e	Second moment of area of the effective cross section
I_g	Second moment of area for the gross section
I_{min}	Minimum value of second moment of area of an edge stiffener about an axis through the mid-thickness of the element to be stiffened

I_n	Second moment of area for the cracked section value under negative moments
I_p	Second moment of area for the cracked section value under positive moments
I_s	Second moment of area of the reinforcement
I_{ser}	Second moment of area of the profiled sheets at serviceability limit state
I_x	Second moment of area about the major axis
I_{xg}	Second moment of area of the gross section
$I_{x,r,h}$	Second moment of area of the effective section under hogging moment due to serviceability load
$I_{x,r,s}$	Second moment of area of the effective section under sagging moment due to serviceability load
I_y	Second moment of area about the minor axis
J	St. Venant's torsion constant
K	Buckling coefficient
L	Span between end supports or Length
L_E	Effective length
L_j	Distance between the centres of two end bolts
L_p	Effective span of the profiled steel sheets
L_s	Effective span of the composite slab
L_v	Shear span
L_z	Effective span
M	Bending moment
M_E	Elastic lateral buckling resistance moment
M_Y	Elastic yield moment of the section
M_b	Buckling moment resistance
M_c	Moment capacity
M_{co}	Plastic moment capacity of the composite cross-section with partial shear connection
M_{cr}	Critical bending moment
M_{cv}	Reduced plastic moment capacity of the composite cross-section under high shear force
M_{cx}	Elastic moment capacity about the major principal x-axis
M_{cy}	Elastic moment capacity about the minor principal y-axis
M_f	Plastic moment capacity of that part of the section remaining after deduction of the shear area A_v
M_o	Maximum moment in the simply supported beam
M_{cp}	Moment capacity of a doubly symmetric composite cross-section
$M_{cp,P}$	Moment capacity of composite cross-section taking account the axial force
M_s	Moment capacity of steel section
M_x	Maximum design moment amplified for the P- Δ - δ effect about the major x-axis
M_y	Maximum design moment amplified for the P- Δ - δ effect about the minor y-axis
M_1, M_2	Moments at the adjacent supports
\overline{M}_x	Maximum first-order linear design moment about the major x-axis

\overline{M}_y	Maximum first-order linear design moment about the minor y-axis
\overline{M}_{LT}	Maximum design moment about the major x-axis governing M_b
N	Number of shear connectors attached to the end of each span of sheets per unit length of supporting beam
N_b	Length of stiff bearing
N_i	Total number of shear connectors between any such intermediate point and the adjacent support
N_n	Number of shear connectors required to develop the negative moment capacity
N_p	Number of shear connectors required to develop the positive moment capacity
P	Design compressive normal force in the composite column or Either P_p or P_n for shear connectors resisting positive or negative moments respectively
P_E	Minimum elastic buckling load
P_{Ex}	Elastic flexural buckling load for a column about the x axis
P_G	Part of this normal force that is permanent
P_L	Permissible capacity per unit length of weld in the longitudinal direction
P_T	Permissible capacity per unit length of weld in the transverse direction or Torsional buckling load of a column
P_{TF}	Torsional flexural buckling load of a column
P_a	End anchorage capacity per shear connector
P_b	Capacity per shear connector for composite beam design
P_{bb}	Bearing capacity of a bolt
P_{bg}	Friction grip bearing capacity
P_{bs}	Bearing capacity of connected parts
P_{bw}	Bearing capacity of unstiffened webs
P_c	Compressive buckling resistance
P_{cs}	Compressive capacity of a member
P_{cx}	Compression resistance under sway mode and about the x-axis
P_{cy}	Compression resistance under sway mode and about the y-axis
P_{cp}	Compression capacity of a composite cross-section
$P_{cp,k}$	Characteristic value of the compression capacity
$P_{cp,cr}$	Critical buckling load for the relevant axis and corresponding to the effective flexural stiffness
P_k	Characteristic resistance of the shear connector
P_n	Resistance of shear connectors against longitudinal shear for negative moments
P_o	Minimum proof loads of bolts
P_p	Resistance of shear connectors against longitudinal shear for positive moments
P_s	Shear capacity of bolts or Stiffener capacity
P_{sL}	Slip resistance provided by a preloaded bolt
P_t	Tension capacity of bolts
P_w	Web crushing capacity of a single web
P_x	Buckling resistance of unstiffened webs

\bar{P}_c	Smaller of the axial force resistance of the column about x- and y-axis under non-sway mode and determined from a second-order analysis or taking member length as the effective length
Q_k	Characteristic imposed load
Q_{ult}	Ultimate design loads
R_c	Resistance of concrete flange
$R_{e,min}$	Specified yield strength of profiled steel sheets
R_{eH}	Upper yield strength
$R_{p,0.2}$	0.2% proof stress
$R_{t,0.5}$	Stress at 0.5% total elongation
R_m	Minimum tensile strength
R_q	Resistance of shear connection
R_r	Resistance of the reinforcement
R_s	Resistance of steel beam
R_v	Resistance of the clear web depth
R_{ult}	Ultimate design resistance
S	Plastic modulus or Fatigue strength of the joint
S_B	Fatigue strength of the same joint using basic design curve
S_v	Plastic modulus of shear area
S_{eff}	Effective plastic modulus
S_{ult}	Ultimate design load effects
S_x	Plastic modulus about the major axis
S_y	Plastic modulus about the minor axis
S_p, S_{ps}, S_{pc}	Plastic section moduli for the steel section, the reinforcement and the concrete of the composite cross-section respectively
S_{pn}, S_{psn}, S_{pcn}	Plastic section moduli of the corresponding components within the region of $2 h_n$ from the middle line of the composite cross-section
T	Flange thickness
T_C	Thickness of connected flange
U_b	Specified minimum tensile strength of bolts
U_e	Minimum tensile strength of the electrode
U_s	Specified minimum tensile strength of the parent metal
V	Applied shear force
V_c	Shear capacity of a member
V_{cr}	Critical shear buckling resistance of a web
V_{crit}	Strouhal critical wind velocity
V_p	Punching shear capacity of a composite slab
V_s	Shear-bond capacity of composite slab
V_v	Vertical shear capacity of composite slab
V_w	Shear buckling resistance of a web
\bar{V}_c	Total longitudinal shear capacity per unit width of slab
\bar{V}_s	Shear bond capacity per unit width
W	Total factored load
W_{ser}	Serviceability loads
Y_{sa}	Average yield strength

Y_f	Specified minimum yield strength of bolts
Y_s	Yield strength
Z	Elastic modulus
Z_c	Elastic modulus of the gross cross-section with respect to the compression flange
Z_{eff}	Effective section modulus
Z_r	Elastic modulus of the section after deduction for the notched material
Z_x	Section modulus about the major axis
Z_y	Section modulus about the minor axis
a	Distance between centres of holes or Spacing of transverse stiffeners or Effective throat size of weld
a_e	Effective area of element for tension
b	Flat width of the compression flange or Outstand
b_a	Mean width of a trough of an open profile
b_b	Minimum width of a trough of a re-entrant profile
b_e	Effective breadth of concrete flange or Effective width of a flat element
b_{eu}	Effective width of a flat unstiffened element
$b_{e,1}$	Portion of the effective width adjacent to the more compressed edge
$b_{e,2}$	Portion of the effective width adjacent to the less compressed edge
$b_{e,3}$	Portion of the effective width adjacent to the tension edge
$b_{e,ser}$	Effective width for a stiffened or an unstiffened flat flange element
$b_{e,1,ser}$	Portion of the effective width adjacent to the more compressed edge
$b_{e,2,ser}$	Portion of the effective width adjacent to the less compressed edge
$b_{e,3,ser}$	Portion of the effective width adjacent to the tension edge
b_d	Developed width of the stiffened element
b_{fc}	Width of the flange for flange curling
b_r	Breadth of the concrete rib
b_t	Portion of the web under tension
c_n	Nominal value of concrete cover
$c_{n,min}$	Minimum concrete cover
d	Diameter of headed shear studs or Diameter of a bolt or Depth of web
d_e	Distance from the centre of a bolt to the end of the connected element in the direction of the bolt force
d_n	Depth of the neutral axis from the middle line of the cross-section
d_p	Diameter of the perforation
d_s	Effective depth of slab to the centroid of profiled steel sheets
d_w	Web depth or sloping distance between the intersection points of a web and the flanges
e	Edge or end distance
e_s	Distance between the neutral axis of the gross cross-section and that of the effective cross-section

e_{sc}	Distance from the shear centre to the centroid measured along the x axis
f_a	Average stress in the flange
f_c	Applied compressive stress
f_{cd}	Design strengths of the concrete
f_{cu}	Cube compressive strength of concrete
$f_{c,1}$	Larger compressive edge stress
$f_{c,2}$	Smaller compressive edge stress
$f_{c,1,ser}$	Larger compressive edge stress due to serviceability loading
$f_{c,2,ser}$	Smaller compressive edge stress due to serviceability loading
f_{sd}	Design strengths of steel reinforcement
f_{ser}	Compressive stress in the effective element under serviceability loading
f_u	Ultimate strength of stud material before cold-drawn
f_v	Shear stress
f_y	Characteristic strength of steel reinforcement
g	Gauge length
g_k	Specified dead load per unit area of the floor or roof
h	Depth of the column section or Overall height of headed shear studs or Storey height
k	Shape correction factor
k_r	Empirical parameter
k_{sc}	Degree of shear connection
m	Equivalent uniform moment factor
m_r	Empirical parameter
m_x, m_y	Equivalent uniform moment factor for flexural buckling about x- and y-axis
m_{LT}	Equivalent moment factor for lateral-flexural buckling
ρ_b	Bending strength (lateral-torsional buckling)
ρ_{bb}	Bearing strength of a bolt
ρ_{bs}	Bearing strength of connected parts
ρ_c	Compressive strength
ρ_{cr}	Local buckling strength of the element
ρ_{ed}	Compressive strength for edge loading
$\rho_{r,cr}$	Elastic critical buckling strength
ρ_s	Shear strength of bolts
ρ_t	Tension strength of a bolt
ρ_v	Average shear strength
ρ_w	Design strength of a fillet weld
ρ_y	Design strength of the structural steel section
ρ_{yf}	Design strength of the flange
ρ_{yp}	Design strength of the pin
ρ_{yr}	Design strength reduced for slender sections
ρ_{ys}	Design strength of stiffener
ρ_{yw}	Design strength of the web
g_k	Specified imposed floor or roof load per unit area
q_w	Shear buckling strength of a web

r	Ratio of the mean longitudinal stress in the web to the design strength <i>or</i> Internal radius of corner
r_l	Radius of gyration of the compound section about the axis parallel to the webs based on nominal geometric properties
r_{cy}	Minimum radius of gyration of an individual section
r_o	Polar radius of gyration about the shear centre <i>or</i> Limiting radius of effective corners
r_x	Radius of gyration about the major axis
r_y	Radius of gyration about the minor axis
s	Longitudinal spacing between adjacent interconnections <i>or</i> Distance between centres of bolts normal to the line of force <i>or</i> Leg length of a fillet weld
s_p	Staggered pitch
s_r	Semi-perimeter of the stiffener
s_t	Transverse spacing centre-to-centre of the studs <i>or</i> Mean transverse spacing of the ties
t	Web thickness
t_B	Maximum thickness relevant to the basic curve
t_c	Stem of connected structural member
t_e	Effective thickness in the perforated zones
t_f	Column flange thickness
t_p	Thickness of the profiled steel sheet <i>or</i> Thickness of a connected part
t_w	Column web thickness
t_3	Thickness of the member in contact with the screw head or the preformed rivet head
t_4	Thickness of the member remote from the screw head or the preformed rivet head
w	Load intensity on the beam acting on a bearing length of $s/2$ each side of the interconnections under consideration
u	Buckling parameter of a cross-section
v	Total longitudinal shear force per unit length <i>or</i> Slenderness factor for a beam
v_c	Design concrete shear stress
v_p	Contribution of the profiled steel sheeting in resisting transverse shear force
v_r	Effective transverse shear resistance of profiled steel sheeting
v_1	Value of v_r for ribs perpendicular to the span
v_2	Value of v_r for ribs parallel to the span
x	Torsional index of a cross-section
x_c	Depth of concrete in compression at mid-span
y	Distance from the flange to the neutral axis
z	Lever arm
α_e	Effective modular ratio
α_L	Modular ratio for long term loading
α_s	Modular ratio for short term loading
α_{TF}	Torsional flexural buckling parameter
β	Equivalent moment factor

	<i>or</i> Ratio of the smaller end moment to the larger end moment M in the unbraced length of a section
γ_a	Partial safety factor of steel section
γ_c	Partial safety factor of concrete
γ_f	Load factor
γ_{m1}	Partial material factor for minimum yield strength of steel material
γ_{m2}	Partial material factor for minimum tensile strength of steel material
γ_s	Partial safety factor of steel reinforcement
δ	Steel contribution ratio
δ_N	Notional horizontal deflection of the upper storey relative to the lower storey due to the notional horizontal force
δ_c	Deflection of a continuous beam at mid-span <i>or</i> Deflection of a composite beam with full shear connection
δ_s	Deflection of the steel beam acting alone
δ_o	Deflection of a simply supported beam for the same loading
ϵ	$(275/\rho_y)^{0.5}$
α	Perry coefficient <i>or</i> Coefficient of linear thermal expansion
α_L	Modular ratio for long term loading
α_s	Modular ratio for short term loading
λ	Relative slenderness
λ_{cr}	Elastic critical load factor
λ_{eff}	Effective slenderness ratio
λ_{LO}	Limiting equivalent slenderness (lateral-torsional buckling)
λ_{LT}	Equivalent slenderness (lateral-torsional buckling)
λ_w	Web slenderness
λ_o	Limiting slenderness (axial compression)
$\bar{\lambda}$	Relative slenderness for the plane of bending being considered
μ	Moment resistance ratio obtained from the interaction curve
μ_d	Reduction factor for moment resistance in the presence of axial force
ρ_L	Proportion of the total loading which is long term
φ_t	Creep coefficient
χ	Reduction factor for the relevant buckling mode
χ_{pm}	Axial resistance ratio due to the concrete
χ_d	Design axial resistance ratio
Δ	Deflection for the given loading system
Δ_c	Deflection corresponding to M_c calculated using the reduced cross-section
Δ_{cr}	Deflection of the beam corresponding to M_{cr} calculated using the full cross-section
ν	Poisson's ratio
τ	Design shear strength
Ω	Arching ratio

Diagrams of typical welding symbols are given in Annex C.

2 LIMIT STATE DESIGN PHILOSOPHY

2.1 GENERAL

2.1.1 Introduction

Structures should be designed using the methods given in the clauses 2.1.2 to 2.1.6. In applying a particular method, the design of the joints should fulfil the assumptions made in that method without adversely affecting any other part of the structure.

2.1.2 Simple design

The distribution of forces may be determined assuming that members intersecting at a joint are pin connected. Joints should be assumed not to develop moments adversely affecting either the members or the structure as a whole. The necessary flexibility in the connections, other than the bolts, may result in some non-elastic deformation of the materials.

A separate structural system, e.g. bracing, is required to provide lateral restraint in-plane and out-of-plane, to provide sway stability and to resist horizontal forces, see clauses 2.1.3 and 6.3.

2.1.3 Continuous design

Elastic or plastic analysis may be used. In elastic analysis, the joints should have sufficient rotational stiffness to justify analysis based on full continuity. The joints should also be capable of resisting the forces and moments resulting from the analysis.

In plastic analysis, the joints should have sufficient moment capacity to justify analysis assuming plastic hinges in the members. They should also have sufficient rotational stiffness for in-plane stability.

Stability should be properly considered in all the analyses.

For steel with yield strengths greater than 460 N/mm² but less than or equal to 690 N/mm², the global elastic analysis shall be adopted to design structural members while the cross section and the member resistances are determined in accordance with the cross-section classifications of the members.

2.1.4 Semi-continuous design

Semi-continuous design may be used where the joints have some degree of strength and stiffness which is insufficient to develop full continuity. Elastic or plastic analysis may be used. The moment capacity, rotational stiffness and rotation capacity of the joints shall be based on experimental evidence or advanced elasto-plastic analysis calibrated against tests. This may allow some limited plasticity, provided that the capacity of the bolts or welds is not the failure criterion. On this basis, the design should satisfy the strength, stiffness and in-plane stability requirements of all parts of the structure when partial continuity at the joints is taken into account in determining the moments and forces in the members.

2.1.5 Design justification by tests

In cases where design of a structure or element by calculation in accordance with the methods in clauses 2.1.2 to 2.1.4 is not practicable or is inappropriate the design, in terms of strength, stability, stiffness and deformation capacity, they may be confirmed by appropriate loading tests carried out in accordance with section 16.

2.1.6 Performance-based design

The Code may accept new and alternative methods of design. A performance-based approach to design may be adopted by the Responsible Engineer subject to providing adequate design justification acceptable to the BA that it meets the requirements of the

aims of design given in clause 1.2.1. The design may be substantiated by tests if necessary.

2.1.7 Calculation accuracy

In structural design, values of applied loads and properties of materials are not known exactly and this lack of precision is recognized in the partial factor approach. Therefore, in justification calculations or when assessing test results, the observed or calculated result of a test or analysis should be rounded off to the same number of significant figures as in the relevant value recommended in the Code.

2.1.8 Foundation design

The design of foundations should be in accordance with the current Hong Kong Code of Practice on Foundations, recognized geotechnical engineering principles and GEO guidance documents. Foundations should safely accommodate all the forces imposed on them. Attention should be given to the method of connecting the steel superstructure to the foundations and to the anchoring of any holding-down bolts as recommended in section 9.

Forces and moments acting on foundations should be clearly specified and especially as to whether the loads are factored or unfactored and, if factored, the relevant partial load factors for each load in each combination should be stated.

2.2 LIMIT STATE PHILOSOPHY

Limit state design considers the functional limits of strength, stability and serviceability of both single structural elements and the structure as a whole. This contrasts with allowable stress design which considers permissible upper limits of stress in the cross-sections of single members. Limit state design methods may accord more logically with a performance-based design approach.

Limit State Design is based on the requirement that the 'Resistance' of the structure (R) should exceed the 'Load Effects' (L) for all potential modes of failure, including allowance for uncertainties in load effects and variability in resistance and material properties.

$$\text{i.e. } R > L \quad (2.1)$$

The load effects, L, shall be determined by normal structural analysis methods for axial, bending, shear or torsion etc. in structural members and components, multiplied by a partial load factor (γ_f) to give an upper bound estimate for load effects. Resistance effects, R, shall be determined by normal strength of materials, geometry of member and material properties. The material yield strength shall be divided by a partial material factor (γ_{m1}) to give a lower bound estimate for material properties. See section 4 for information on partial factors.

Structures should be designed by considering the limit states beyond which they would become unfit for their intended use. Appropriate partial factors should be applied to provide adequate degrees of reliability for ultimate and serviceability limit states. Ultimate limit states concern the safety of the whole or part of the structure whereas serviceability limit states correspond to limits beyond which specified service criteria are no longer met.

The overall level of safety in any design has to cover the variability of material strength, member dimensions and model variability (γ_{m1}), and loading and variations of structural behaviour from that expected (γ_f).

In the Code, the partial material factor has been incorporated in the recommended design strengths for structural steel, bolts and welds.

The values assigned to the load factor (γ_f) depend on the type of load and the load combination. The specified characteristic loads are multiplied by the partial load factor to check the strength and stability of a structure, see section 4.

Examples of limit states relevant to steel structures are given in Table 2.1. In design, the limit states relevant to that structure or part should be considered.

Table 2.1 - Limit states

Ultimate limit states (ULS)	Serviceability limit states (SLS)
Strength (including general yielding, rupture, buckling and forming a mechanism)	Deflection
Stability against overturning, sliding, uplift and sway stability	Human induced vibration
Fire resistance	Wind induced vibration
Brittle fracture and fracture caused by fatigue	Durability

Note:- For cold-formed steel, excessive local deformation is to be assessed under ultimate limit state.

2.3 ULTIMATE LIMIT STATES (ULS)

Ultimate limit states consider the strength and stability of structures and structural members against failure.

For satisfactory design of an element at ultimate limit states, the design resistance or capacity of the element or section must be greater than or equal to the ultimate design load effects. The design resistance is obtained by reducing the characteristic ultimate strength of the material by a partial material factor. The factored design loads are obtained by multiplying the characteristic loads by partial load factors as mentioned in section 4 and the design load effects are obtained by appropriate calculation from the design loads.

2.3.1 Limit state of strength

When checking the strength of a structure, or of any part of it, the specified loads should be multiplied by the relevant partial factors γ_f given in Tables 4.2 and 4.3 of section 4. The factored loads should be applied in the most unfavourable realistic combination for the effect or part under consideration. The principal combinations of loads which should be taken into account are (1) dead load and imposed load, (2) dead load and lateral load effects and (3) dead load, imposed load and lateral load effects.

In each load combination, a γ_f factor of 1.0 should be applied to beneficial dead load which counteracts the effects of other loads, including dead loads restraining sliding, overturning or uplift.

The load carrying capacity of each member and connection, as determined by the relevant provisions of this Code, should be such that the factored loads would not cause failure.

2.3.2 Stability limit states

2.3.2.1 *General*

Static equilibrium, resistance to horizontal forces and sway stiffness should be checked. The factored loads should be applied in the most unfavourable realistic combination for the part or effect under consideration.

2.3.2.2 *Static equilibrium*

The factored loads, considered separately or in combination, should not cause the structure, or any part of it (including the foundations), to slide, overturn or lift off its seating. The combination of dead, imposed and lateral loads should be such as to have the most severe effect on the stability limit state under consideration. Account should be taken of variations in dead load which may occur during construction or other temporary conditions.

The design shall also comply with the Building (Construction) Regulations for overall stability against overturning, uplift, and sliding on the basis of working loads.

2.3.2.3 *Resistance to horizontal forces*

All structures, including portions between expansion joints, should have adequate resistance to horizontal forces in order to provide a practical level of robustness against the effects of incidental loading.

Resistance to horizontal forces should be provided using one or more of the following lateral load resisting systems: triangulated bracing; moment-resisting joints; cantilevered columns; shear walls; properly designed staircase enclosing walls, service and lift cores or similar vertical elements. Reversal of load direction should be considered in the design of these systems.

The cladding, floors and roof should have adequate strength and be properly fixed to the structural framework so as to provide diaphragm action and to transmit all horizontal forces to the lateral load resisting elements (collector points).

Where resistance to horizontal forces is provided by construction other than the steel frame, the steelwork design documents should clearly indicate the need for such construction and state the forces acting on it, see clause 1.2.

2.3.2.4 *Sway stiffness and resistance to overall lateral or torsional buckling*

All structures should have sufficient sway stiffness so that the vertical loads acting with the lateral displacements of the structure do not induce excessive secondary forces or moments in the members or connections. This requirement shall apply separately to each part of a structure between expansion joints.

Where second order (or “P- Δ ”) effects are significant, they should be explicitly allowed for in the design of the lateral load resisting parts of the structural system. The system should provide sufficient stiffness to limit sway deformation in any horizontal direction and also to limit twisting of the structure on plan (i.e. to prevent global torsional instability).

When “P- Δ ” effects are not significant, the structure may be defined as “non sway” and should still be checked for adequate resistance to notional horizontal forces as defined in clause 2.5.8.

Where moment resisting joints are used to provide sway stiffness, their flexibility should be considered in the analysis of the system. The stiffening effect of masonry infill wall panels or profiled steel sheeting, if present, may be taken into account in the analysis and design. Clause 6.3 describes detailed requirements for the classification of frames.

Member buckling (or “P- δ ”) should always be considered.

2.3.3 **Fatigue**

Fatigue need not be considered unless a structure or an element is subjected to numerous fluctuations of stress. Stress changes due to normal fluctuations in wind loading need not be considered. When designing for fatigue, a partial load factor, γ_f of 1.0 should be used.

The principle of fatigue design is given below, further guidance on calculating fatigue resistance and workmanship where fatigue is critical may be found in references given in Annex A1.10. Where fatigue is critical, the workmanship clauses in sections 14 and 15 do not fully cover such cases and all design details should be precisely defined and the required quality of workmanship should be clearly specified.

Situations where fatigue resistance needs to be considered include the following:

- Where there are wind-induced vibrations due to aerodynamic instability. Normal fluctuations in wind loading need not be considered.
- Structural members that support heavy vibratory plant or machinery.
- Members that support cranes as defined in clause 13.7.
- Bridge structures, which will normally be designed to a bridge design code.

Further attention should be paid to the following conditions when considering the fatigue assessment:

- Corrosion/immersion in water will cause a reduction of fatigue life compared to corresponding behaviour in air.
- Very high stress ranges can give rise to low fatigue life.
- The fatigue life will be reduced at regions of stress concentrations; dependent on their geometry welded joints that may have low inherent fatigue life.

- Fatigue life is reduced for some types of thick welded joints compared to thinner joints.
- Fatigue can be caused by repeated fluctuations in thermal stress due to temperature changes. Normal ambient temperature changes will not normally be a problem of fatigue in building structures.

2.3.3.1 Principles of fatigue design

If a component or structure is subjected to repeated stress cycles, it may fail at stresses below the tensile strength and often below the yield strength of the material. The processes leading to this failure are termed 'fatigue'.

Fatigue failure occurs by the slow progressive growth of cracks under the action of repeated fluctuating stresses. The cracks grow incrementally with each cycle of stress range (S). Cracks initiate at the worst stress concentration region and grow in a direction perpendicular to the maximum fluctuation in principal stresses. Final failure occurs when the crack has grown to a size that either the remaining cross section fails by yielding/plastic collapse or the crack has reached a critical size for fracture. Thus the damage done during the fatigue process is cumulative and not recoverable.

Clauses 2.3.3.2 to 2.3.3.4 below describe the basic design philosophy for fatigue tolerant design.

2.3.3.2 S-N Relationships

Most fatigue design rules are presented as a series of S-N curves for particular construction details where N is the available design life expressed as number of cycles of a repeated stress range S. The stress range is the difference between maximum and minimum stress levels. The basic S-N design curves for particular details, e.g. different geometries of welded or bolted connection, are based on experimental laboratory tests on samples of the same geometry and are usually presented to give a specific probability of failure (e.g. mean minus two standard deviations). Figure 2.1 illustrates schematic S-N curves for fatigue cracks growing in a transverse butt weld and from the toe of a transverse fillet weld on a steel plate.

In general, the S-N curve for a particular material and geometry is affected by the mean stress (average of minimum and maximum stresses) and the stress ratio (ratio of minimum to maximum stress). However, in welded joints, the presence of high welding residual stresses means that the mean stress and stress ratio are always high. The basic S-N design curves for welded joints assume that high residual stresses are present and no adjustment should be made for mean stress or stress ratio due to the applied loading.

A classification system links descriptions of the construction detail with the appropriate basic S-N design curve. The classification is dependant upon the joint type, geometry and direction of loading and it relates to a particular location and mode of cracking.

The basic S-N design curves for parent steels are to some extent dependent on the strength of the material, at least as represented by tests on small smooth laboratory specimens. For welded details, however, the fatigue strengths of as-welded components show no increase in available design stress range at the same life for higher strength steels compared to lower strength steels. Fatigue strengths of some types of welded details are reduced by an increase in thickness of the joint and a correction should be applied as follows:

$$S = S_B \left(\frac{t_B}{t} \right)^{1/4} \quad (2.2)$$

where

- S is the fatigue strength of the joint under consideration, of thickness t,
 S_B is the fatigue strength of the same joint using the basic design curve, derived for thickness t_B, usually taken as 22 mm.
 t is the greater of 16 mm or the actual thickness of the member or bolt;
 t_B is the maximum thickness relevant to the basic S-N design curve.

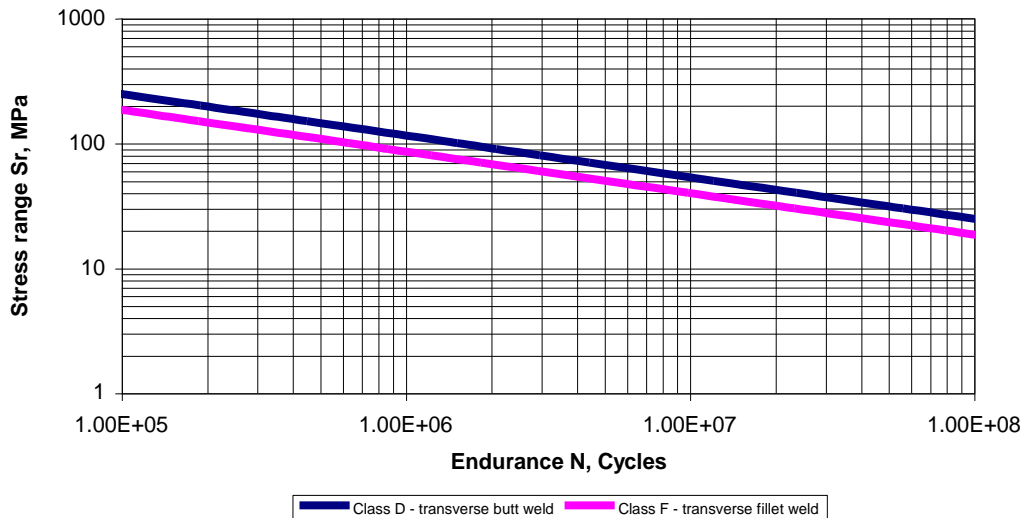

Figure 2.1 - Typical S-N curves for welded steel

The basic S-N design curves are established by constant amplitude test data and are based upon two standard deviations below the means line assuming a log normal distribution, with a normal probability of failure of 2.3%.

2.3.3.3 *Design approaches*

There are two basic approaches to fatigue design:

- Damage tolerant design, and
- Safe life design.

The inherent scatter in fatigue performance and the likelihood of structures being used beyond the intended design life raises the possibility of in-service fatigue cracking. The intent of damage-tolerant (robustness) design is to ensure that should fatigue cracking occur in service, the remaining structure can sustain the maximum working load without failure until the damage is detected.

In situations where regular inspection is not possible, or is otherwise impractical, a safe life design approach is considered appropriate. This is achieved in practice by ensuring that the calculated life is many times greater than the required service life.

2.3.3.4 *Fatigue assessment procedure*

A structural element may contain several fatigue crack initiation sites. The regions of the structure subjected to the highest stress fluctuations and/or containing the severest stress concentrations would normally be checked first. The basic procedure can be summarized as follows:

- a) Select the required design working life of the structure, e.g. for a building designed to the Code the design working life is 50 years and for road/bridge this is normally taken as 120 years.
- b) Estimate the loading expected in the life of the structure.
- c) Estimate the resulting stress history at the detail under consideration.
- d) Reduce the i th stress history to an equivalent number of cycles n_i of different stress ranges S_{ri} using a cycle counting technique such as the rainflow or reservoir cycle counting methods. See Annex A1.10 for acceptable references.
- e) Rank the cycles in descending order of stress range to form a stress spectrum.
- f) Classify each detail in order to identify the appropriate S-N curve.
- g) Modify the basic S-N design curve as appropriate to allow for variable such as material thickness, corrosion or weld improvement methods.
- h) For each stress range of the spectrum S_{ri} determined in (d) and (e) above, determine the available number of cycles N_i from the basic S-N design curve for the detail concerned. Determine the fatigue damage at this stress range as the ratio of the number of cycles applied at this stress range, n_i , to the number of

cycles available, N_i . Miner's Law states that the sum of the ratios n_i/N_i for all stress ranges reaches unity for failure. For design purposes, the requirement based on the Miner's summation is therefore as follows:

$$\sum \left(\frac{n_i}{N_i} \right) \leq 1 \quad (2.3)$$

- i) If the Miner's summation is unsatisfactory, modify the peak stress range (and hence all other stress ranges) or the joint classification so as to give a satisfactory value which is equal to or less than 1.0.

2.3.4 Structural integrity and robustness

2.3.4.1 *General*

To provide structural integrity and robustness and to minimise the risk of localized damage causing progressive collapse, buildings should satisfy the following:

- (a) Provide tension continuity tying in both vertically and horizontally.
- (b) Ability to resist to a minimum notional horizontal load.
- (c) Ability to withstand removal of a vertical element by establishing alternative load paths to limit the extent of damage or collapse. Substantial permanent deformation of members and their connections is acceptable when considering removal of elements.
- (d) Design of key elements.

Each part of a building between expansion joints should be treated as a separate building.

2.3.4.2 *Principles of tension continuity tying of buildings*

The structure of buildings should be effectively tied together at each principal floor level. Every column should be effectively held in position by means of horizontal ties in two directions, approximately at right angles, at each principal floor level supported by that column. Horizontal ties should also be provided at roof level, except where the steelwork only supports lightweight cladding weighing not more than 0.7 kN/m² and only carries wind and imposed roof loads.

Continuous lines of ties should be arranged as close as practicable to the edges of the floor or roof and to each column line, see Figure 2.2. At re-entrant corners the tie members nearest to the edge should be anchored into the steel framework as indicated in Figure 2.2. All horizontal ties and their end connections should be robust and ductile.

The horizontal ties may be structural steel members (including those also used for other purposes); or steel bar reinforcement anchored to the steel frame and embedded in concrete; or steel mesh reinforcement in a composite slab with profiled steel sheeting acting compositely with steel beams. The profiled steel sheets should be directly connected to the beams by the shear connectors, see section 10.

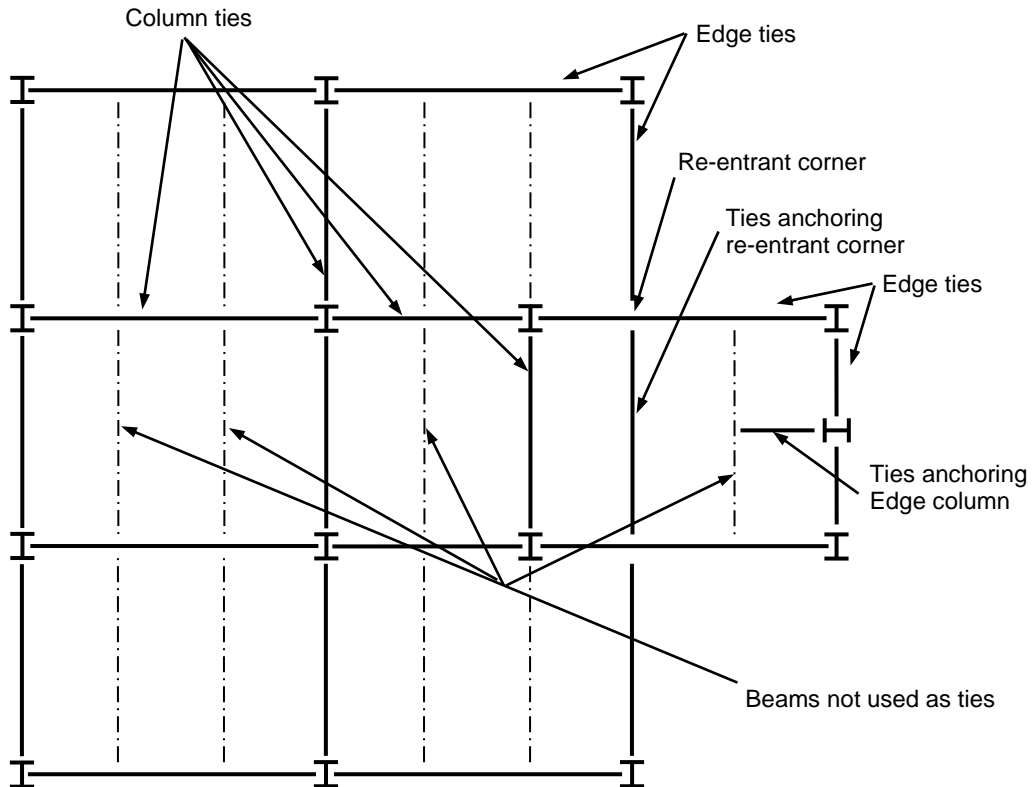

Figure 2.2 - Examples of tying columns of a building

2.3.4.3 Avoidance of disproportionate collapse

Steel-framed buildings designed to the Code may be assumed not to be susceptible to disproportionate collapse provided that the following conditions are met.

- a) **General tying.** Horizontal ties generally, as described in clause 2.3.4.2, should be arranged in continuous lines wherever practicable, and distributed throughout each floor and roof level in two directions approximately at right angles, see Figure 2.3.

Steel members acting as horizontal ties, and their end connections, should be capable of resisting a factored tensile load not less than 75kN, which need not be considered as additive to other loads. Horizontal ties that consist of steel reinforcement should be designed as recommended in the Code of Practice for Structural Use of Concrete. The tie forces should be calculated as follows:

$$\text{for internal ties: } 0.5 (1.4G_k + 1.6Q_k) s_t L \text{ but not less than } 75 \text{ kN;} \quad (2.4)$$

$$\text{for edge ties: } 0.25 (1.4G_k + 1.6Q_k) s_t L \text{ but not less than } 75 \text{ kN.} \quad (2.5)$$

where:

G_k is the specified dead load per unit area of the floor or roof;

L is the span of the tie;

Q_k is the specified imposed floor or roof load per unit area;

s_t is the mean transverse spacing of the ties adjacent to that being checked.

This may be assumed to be satisfied if, in the absence of other loading, the member and its end connections are capable of resisting a tensile force equal to its end reaction under factored loads, or the larger end reaction if they are unequal, but not less than 75 kN.

- b) **Tying of edge columns.** The horizontal ties anchoring the columns nearest to the edges of a floor or roof should be capable of resisting a factored tensile load, acting perpendicular to the edge, equal to the greater of the tie force as calculated in (a) above, 75 kN or 1% of the maximum factored dead and imposed load in the column immediately above or below that level.

High-rise buildings with outrigger systems or external truss systems often have very large perimeter columns or mega columns. Lateral stability and tying in of such columns requires special consideration as the restraint forces can be large and is referred to clause 13.1.

- c) **Continuity of columns.** All columns should be carried through at each beam-to-column connection unless the steel frame is fully continuous in at least one direction. All column splices should be capable of resisting a tensile force equal to the largest factored vertical reaction, from dead and imposed load or from dead, wind and imposed load, applied to the column at a single floor level located between that column splice and the next column splice below.
- d) **Resistance to horizontal forces.** Braced bays or other systems for resisting horizontal forces as recommended in clause 2.3.2.3 should be distributed throughout the building such that, in each of the two directions approximately at right angle, no substantial portion of the building is connected at only one point to a system resisting the horizontal forces.
- e) **Precast floor units.** Where precast concrete or other heavy floor or roof units are used, they should be properly anchored in the direction of their span, either to each other over a support or directly to their supports as recommended in the Code of Practice for Precast Concrete Construction.

If any of the first three conditions a) to c) is not met, the building should be checked, taking each storey in turn, to ensure that disproportionate collapse would not be initiated by the hypothetical removal, one at a time, of each column. If condition d) is not met, a check should be made in each storey in turn to ensure that disproportionate collapse would not be initiated by the hypothetical removal, one at a time, of each element of the systems providing resistance to horizontal forces. The portion of the building at risk of collapse should not exceed 15% of the floor or roof area or 70 m² (whichever is less) at the relevant level and at one immediately adjoining floor or roof level, either above or below it. If the hypothetical removal of a column, or of an element of a system providing resistance to horizontal forces, would risk the collapse of a greater area, that column or element should be designed as a key element, as recommended in clause 2.5.9.

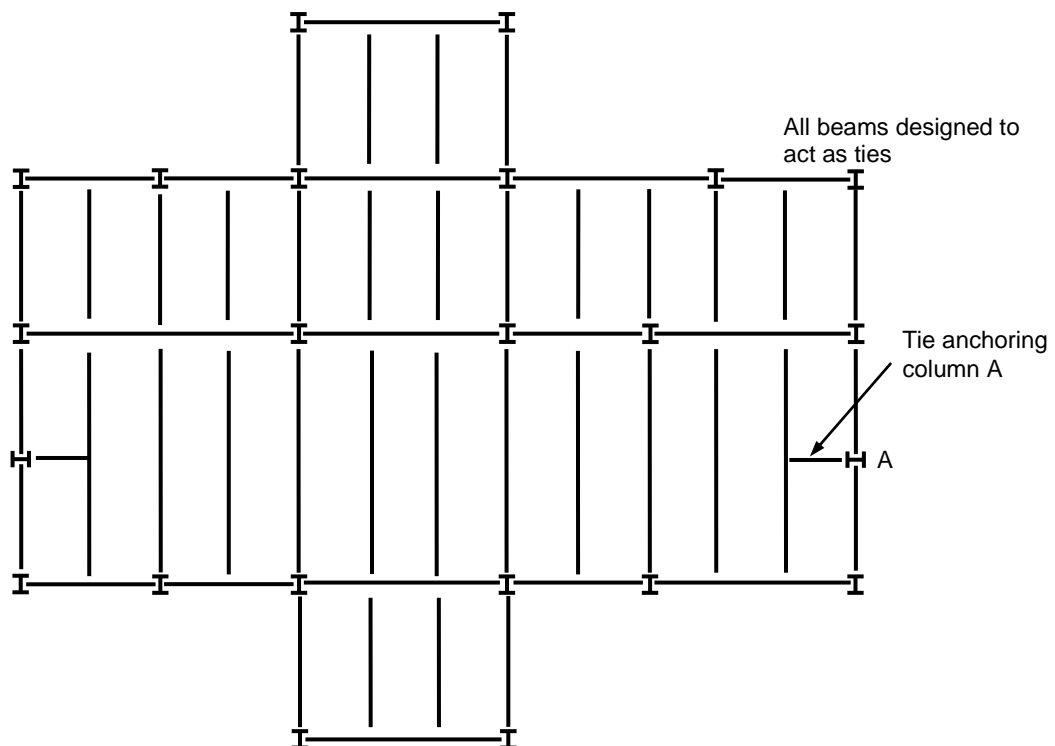

Figure 2.3 - Examples of general tying of a building

2.3.5 Brittle fracture

Brittle fracture can occur in welded steel structures subjected to tensile stresses at low temperatures. In situations where fracture sensitive connection details, inappropriate fabrication conditions or low toughness weld materials, etc, are used, brittle fracture can also occur at normal temperatures. The problem is tackled by specifying steels and welded joints with appropriate grades of fracture toughness, usually implemented in practice by specifying grades of notch ductility in the Charpy test. Higher notch ductility grades are required for thicker steels and joints. Guidance on selection of appropriate grades of notch ductility is given in clause 3.2.

2.4 SERVICEABILITY LIMIT STATES (SLS)

Serviceability limit states consider service requirements for a structure or structural element under normally applied loads. Examples are deflection, human induced vibration, wind induced vibration and durability. They are described in section 5.

For satisfactory design of an element at serviceability limit states, the serviceability design resistance must be greater than or equal to the serviceability design load effects. Typically value of load factors for serviceability calculations is 1.0.

2.4.1 Serviceability loads

Normally the serviceability loads should be taken as the specified characteristic loads, i.e. unfactored.

Exceptional snow load, for cold regions, caused by local drifting on roofs, should not be included in the imposed load when checking serviceability.

In the case of combined wind and imposed loads, only 80% of the full characteristic values need be considered when checking serviceability. In the case of combined horizontal crane loads and wind load, only the greater effect need be considered when checking serviceability.

In calculating most probable deflections for composite elements, it may be necessary to consider creep effects. In such a case, it is necessary to estimate the proportion of live load which is permanent and the proportion which is transitory. For normal domestic and office use, 25% of the imposed load should be considered permanent and 75% considered transitory. For filing and storage, 75% of the imposed load should be considered permanent and for plant floors, the full imposed load should be used.

2.5 LOADING

2.5.1 General

All relevant loads should be considered separately and in such realistic combinations as to give the most critical effects on the elements being designed and the structure as a whole. The magnitude and frequency of fluctuating loads should also be considered.

Loading conditions during erection should be carefully considered. Settlement of supports should be considered where necessary, see clause 2.5.5.

2.5.2 Dead and imposed loading

Refer to the Building (Construction) Regulations for characteristic dead and imposed loads.

For design in countries or regions other than Hong Kong, loads can be determined in accordance with local or national provisions.

2.5.3 Wind loading

Refer to the current Code of Practice on Wind Effects in Hong Kong for characteristic wind loads.

For design in countries or regions other than Hong Kong, wind loads should be determined in accordance with the relevant local or national provisions.

The minimum unfactored wind load should not be less than 1.0% of unfactored dead load in the appropriate load combinations 2 and 3 defined in clause 4.3. This load shall be applied at each floor and calculated from the weight of that floor and associated vertical structure.

For the design of internal structures such as temporary seating in a concert hall, the design unfactored lateral load shall be the greater of 1% of unfactored dead plus imposed loads acting on the floors supporting the internal structures or that obtained from a lateral pressure of 0.5 kN/m² multiplied by the appropriate load factor. This pressure should be applied to the enclosing elevation of the structure.

If the specified loads from overhead travelling cranes already include significant horizontal loads, it will not be necessary to include vertical crane loads when calculating the minimum wind load.

2.5.4 Loads from earth and water pressure

Nominal earth and ground-water loads shall be determined in accordance with actual geotechnical conditions and relevant Hong Kong GEO guidance documents.

For design in countries or regions other than Hong Kong, nominal earth and ground water loads shall be determined in accordance with the relevant national or local standards.

2.5.5 Load effects from differential settlement of foundations

In cases where the designer considers the effect of differential settlement of foundations is significant either to an ultimate limit state or to a serviceability limit state, they shall be considered in the design of the structure. The most probable differential settlements may be calculated using appropriate geotechnical methods.

2.5.6 Load effects from temperature change

Where, in the design and erection of a structure, it is necessary to take into account of changes in temperature, it may be assumed that in Hong Kong, the average temperature varies from +0.1°C to +40.0°C. The actual range, however, depends on the location, type and purpose of the structure and special consideration may be necessary for structures in other conditions, and in locations outside Hong Kong subjected to different temperature ranges. For some structures such as pre-tensioned rod and cable structural systems, structural stability and designed pre-tension force very much depend on the assumed temperature change and special attention should be paid on design of this structural form, see clause 13.3. Clause 13.3.4.3 provides more detailed guidance for temperatures of elements exposed to sunlight.

2.5.7 Loads from cranes

2.5.7.1 Loads from overhead traveling cranes

The vertical and horizontal dynamic loads and impact effects from overhead travelling cranes should be determined in accordance with clause 13.7 and in considering the limits specified by the crane manufacturer.

Wind loads on outdoor overhead travelling cranes should be obtained from the current HKWC or other appropriate regional wind code. Reference should be made to clause 13.7.1 for cranes under working conditions.

The partial load factors given in Table 13.3 for vertical loads from overhead travelling cranes should be applied to the dynamic vertical wheel loads, i.e. the static vertical wheel loads increased by the appropriate allowance for dynamic effects.

Where a structure or member is subject to loads from two or more cranes, the crane loads should be taken as the maximum vertical and horizontal loads acting simultaneously where this is reasonably possible.

2.5.7.2 *Loads from tower, derrick and mobile cranes*

Where it is required to check the permanent structure for loads imposed from a tower, derrick or mobile crane, the imposed loads should be established from all combinations in consultation with the crane supplier and the building contractor. These combinations shall include loads in service and abnormal loads during adverse wind conditions, e.g. typhoon. Prevention for uplift resistance shall be provided. This data should include loads arising from an envelope of all possible load positions in plan, slew and azimuth angles.

2.5.8 **Notional horizontal forces**

All practical structures contain imperfections such as lack of verticality and straightness of members. To take into account of this, the lateral load resisting system of all structures should be capable of resisting notional horizontal forces with a minimum of 0.5% of the factored dead and imposed loads applied at the same level as the vertical loads. A minimum notional lateral pressure of 0.5 kN/m² shall be used if this gives a higher lateral load than 0.5% of factored dead and imposed load. This pressure should be applied to the enclosing elevation of the structure. No further partial load factor need be applied.

For certain temporary works in construction and sway ultra-sensitive structures, such as internal platform floors, scaffolding, false work and grandstands, a larger minimum horizontal force shall be used. The magnitude of this force shall be the greater of 1.0% of factored dead and live loads applied at the same level or a notional lateral pressure of 1.0kN/m² on the enclosing elevation of the structure.

The notional horizontal forces should be assumed to act in any one direction at a time and should be applied at each roof and floor level or their equivalent. They should be taken as acting simultaneously with the factored vertical dead and imposed loads in load combination 1, see section 4.

The notional horizontal forces need not be applied when considering overturning, pattern loads, in combination with other applied horizontal loads or with temperature effects. They need not be taken to contribute to the net reactions at the foundations.

If the specified loads from overhead travelling cranes already include significant horizontal loads, the vertical crane loads need not be included when calculating notional horizontal forces.

Reference should be made to the Code of Practice for Demolition of Buildings for the magnitude of notional horizontal force for supporting structures used in demolition works.

As an alternative to considering notional horizontal forces, the initial imperfections of a structure may be explicitly considered in a non-linear "P-Δ" analysis as described in clause 6.4.

The following table summarises the lateral forces to be considered in design for the principle combinations of load given in clause 4.3.

Table 2.2 - Summary of lateral forces to be considered

Description of load	Principal load combination	Value to be used, larger value of
Notional horizontal force for normal structures	Load combination 1	0.5% of factored dead plus live load or 0.5kN/m ² notional horizontal pressure. The value used need not be factored further.
Notional horizontal force for temporary works in construction (excluding hoarding structures) and sway ultra-sensitive structures	Load combination 1	1.0% of factored dead plus live load or a minimum notional lateral pressure of 1.0 kN/m ² . The value used need not be factored further.
Lateral loads from wind	Load combinations 2 and 3	Actual wind load, 1.0% of unfactored dead load, or for internal structures a lateral pressure of 0.5kN/m ² . The load used should be multiplied by the appropriate factor for that combination.
Lateral loads from soil and water	Load combinations 2 and 3	Actual values as calculated. The load used should be multiplied by the appropriate factor for that combination.

Note: Refer to the Code of Practice for Demolition of Buildings for appropriate notional horizontal forces for structures under demolition.

2.5.9 Exceptional loads and loads on key elements

Exceptional load cases can arise either from an exceptional load such as an impact from a vehicle (ship, lorry, aeroplane) or explosion, or from consideration of the remaining structure after removal of a key element.

In a building that is required to be designed to avoid disproportionate collapse, a member that is recommended in clause 2.3.4.3 to be designed as a key element should be designed to resist exceptional loading as specified here. Any other steel member or other structural component that provides lateral restraint vital to the stability of a key element should itself also be designed as a key element for the same exceptional loading. The loading should be applied to the member from all horizontal and vertical directions, in one direction at a time, together with the reactions from other building components attached to the member that are subject to the same loading, but limited to the maximum reactions that could reasonably be transmitted, considering the breaking resistances of such components and their connections.

Key elements and connections should be designed to resist an explosion pressure of 34 kN/m² or the impact force from a vehicle if considered necessary and possible. Normal nominal design impact forces from vehicles shall be as specified in the current Building (Construction) Regulations.

Table 4.3 contains the load factors and combinations with normal loads to be used in these situations and takes into account of the reduced probability of other loads acting in combination with the exceptional event.

2.5.10 Loads during construction

Loads which arise during construction shall be considered in the design.

2.5.11 Loads on temporary works in construction

The most adverse loading situation arising from the intended construction works should be considered in the design.

3 MATERIALS

3.1 STRUCTURAL STEEL

3.1.1 General

This clause covers the design of structures fabricated from normal strength structural steels with a design strength not exceeding 460 N/mm² from one of the following classes:

Class 1: Steel complying with one of the reference material standards in Annex A1.1 and basic requirements given in clause 3.1.2 and produced from a manufacturer with an acceptable Quality Assurance system.

Class 2: Steel which has not been manufactured to one of the reference material standards in Annex A1.1 but is produced from a manufacturer with an acceptable Quality Assurance system. Such steel shall be tested to show that it complies with one of the reference material standards in Annex A1.1 before being used. Requirements on the sampling rate for testing are given in Annex D1.

Class 3: Uncertified steel; steel not covered by Class 1, Class 2. Tensile tests shall be carried out on such steel to show that it fulfils the intended design purpose before being used. Requirements on the sampling rate for testing are given in Annex D1. Restrictions and limited applications are imposed on the use of this material, see clause 3.1.4.

Hot rolled steels and cold-formed structural hollow sections are covered in clause 3.1 and cold formed steel open sections and profiled sheets are covered in clause 3.8.

Class 1H: High strength steels with yield strengths greater than 460 N/mm² but less than or equal to 690 N/mm² and complying with one of the reference material standards in Annex A1.1. Basic requirements for the steel and producer are given in clause 3.1.2 and high strength steels shall be produced from a manufacturer with an acceptable Quality Assurance system.

Class UH: Ultra high strength steels with yield strengths greater than 690 N/mm² are not covered by the Code. Subject to the approval of the Building Authority, they may be used in bolted tension applications in the form of proprietary high strength tie rods or bars, or in other applications. In these cases, the Responsible Engineer shall provide a full justification and ensure that all requirements are met in the submission of this material to the Building Authority.

The Code covers both elastic and plastic analysis and design. Plastic analysis and design is not permitted for uncertified steels or for steels with yield strength greater than 690 N/mm².

High strength steels may give advantages for certain ultimate limit states such as compression resistances in heavily loaded columns and moment resistances in long span beams, but with limited improvement in very slender columns undergoing primarily elastic buckling. Pre-cambering may be adopted to reduce beam deflections under dead and imposed loads. Their use does not improve the performance for fatigue and serviceability limit states.

For a particular project, it is good practice to use steel from one source of supply.

Table 3.1 - Strength grade summary table

Strength Grade	Class	Acceptable Quality Assurance system	Compliance with reference material Standard	Additional test Required	Remarks
$Y_s \leq 460$	1	Y	Y	N	Normal use
	2	Y	N	Y	Can be used subject to satisfactory tests
	3	N	-	Y	Restricted use with limited applications
$460 < Y_s \leq 690$	1H	Y	Y	N	Normal use

Note: Reference standards refer to acceptable standards adopted in Australia, China, Japan, United States of America and British versions of European Union Standards. For sampling rate of testing frequency, refer to Annex D1.

3.1.2 Design strength for normal strength steels and high strength steels

The design strength, p_y , for steel is given by:

$$p_y = \frac{Y_s}{\gamma_{m1}} \text{ but not greater than } \frac{U_s}{\gamma_{m2}}$$

where

Y_s the yield strength is defined as:

- the upper yield strength, R_{eH} , the stress at the initiation of yielding for steel materials with clearly defined yield point; or
- if the yield point cannot be clearly defined, then the 0.2% proof stress, $R_{p0.2}$, or the stress at 0.5% total elongation, $R_{t0.5}$ for steel materials whichever is smaller.
- In case of dispute, the 0.2% proof stress, $R_{p0.2}$, shall be adopted.

U_s is the minimum tensile strength, R_m .

γ_{m1} , γ_{m2} are the material factors given in Table 4.1. These material factors are minimum values and the design strengths should not be greater than those given in the respective material standards.

For the more commonly used grades and thicknesses of Class 1 steels supplied in accordance with European BS EN, Chinese GBJ, American ASTM, Australian AS and Japanese JIS standards for hot rolled steel, the value of design strength p_y is given in Tables 3.2 to 3.6 respectively. Alternatively, the design strength p_y may be obtained from the formula above using values of minimum yield strength and minimum tensile strength given in the relevant steel product standard, see Annex A1.1. (The design strengths should not be greater than those given in the respective material standards.)

The Code requires that steel product manufacturers produce sections to their stated nominal sizes within their specified +/- tolerances such that average section sizes and properties are at least the nominal values. The Responsible Engineer shall ensure that any steel used complies with this or he shall take into account of any adverse variation in his design.

The essentials of the basic requirements for normal strength steels are:

- Strength:**

The design strength shall be the minimum factored yield strength Y_z/γ_{m1} but not greater than the minimum tensile strength U_s/γ_{m2} where γ_{m1} and γ_{m2} are given in Table 4.1.

Resistance to brittle fracture:

The minimum average Charpy V-notch impact test energy at the required design temperature shall be in accordance with clause 3.2 of the Code in order to provide sufficient notch toughness.

- **Ductility:**

The elongation on a gauge length of $5.65\sqrt{S_0}$ where S_0 is the cross sectional area of the section, should be as follows:

For Classes 1 and 2 steel, the elongation at fracture is not to be less than 15%;

For Class 1H steel, the elongation at fracture is not to be less than 10%; and

The strain at the tensile strength should not be greater than 15 times the strain at the yield strength.

- **Weldability:**

The chemical composition and maximum carbon equivalent value for Classes 1, 2 and 1H steel shall conform to the respective reference materials standard in Annex A1.1.

The minimum requirements on the chemical composition of the materials for Class 3 steel when welding is involved are as follows:

- a) The maximum carbon equivalent value shall not exceed 0.48% on ladle analysis and the carbon content shall not exceed 0.24%;
- b) For general applications, the maximum sulphur content shall not exceed 0.03% and the maximum phosphorus content shall not exceed 0.03%; and
- c) When through thickness quality (Z quality) steel is specified, the sulphur content shall not exceed 0.01%.

The chemical compositions of various grades of steel shall also conform to the requirements stipulated in the national material standards to which where they are manufactured.

For cold-formed thin gauge steel open sections and sheet profiles as stipulated in clauses 11.1 to 11.6, only the basic requirements on strength and ductility are applicable as given in clauses 3.8.1.1 and 3.8.1.2. Typical design strengths for cold-formed thin gauge steel open sections and sheet profiles are given in clause 3.8.1.1.

For cold-formed steel hollow sections as stipulated in clause 11.7, the basic requirements on strength and ductility are applicable as given in this clause. For cold-formed steel pile sections as stipulated in clause 11.8, the basic requirements on strength and ductility are also applicable as given in this clause.

Table 3.2 - Design strength p_y for steels supplied in accordance with BS EN standards (plates, hot rolled sections, hot finished and cold formed hollow sections, cold formed sections and profiled sheets)

Steel grade	Thickness less than or equal to (mm)	Design strength p_y (N/mm ²)
S235	16	235
	40	225
	63	215
	80	215
	100	215
	150	205
S275	16	275
	40	265
	63	255
	80	245
	100	235
	150	225
S355	16	355
	40	345
	63	335
	80	325
	100	315
	150	295
S450	16	450
	40	430
	63	410
	80	390
	100	380
S460	16	460
	40	440
	63	430
	80	410
	100	400
S550	50	550
	100	530
	150	490
S690	50	690
	100	650
	150	630

Note that the thickness of the thickest element of the cross section should be used for strength classification of rolled sections.

Table 3.3 - Design strength p_y for steels supplied in accordance with Chinese standard GB50017 (plates, hot rolled sections, hot finished and cold formed hollow sections, cold formed sections and profiled sheets)

a) Q235 ~ Q460 steel

Steel grade	Thickness less than or equal to (mm)	Design strength p_y (N/mm ²)
Q235	16	215
	40	205
	100	200
Q345/Q355	16	305
	40	295
	63	290
	80	280
	100	270
Q390	16	345
	40	330
	63	310
	100	295
Q420	16	375
	40	355
	63	320
	100	305
Q460	16	410
	40	390
	63	355
	100	340

b) Q550 ~ Q690 steel

Steel grade	Thickness less than or equal to (mm)	Design strength p_y (N/mm ²)
Q550	16	520
	40	500
	63	475
	80	455
	100	445
Q690	16	630
	40	615
	63	605
	80	585

Table 3.4 - Design strength p_y for North American steel supplied to ASTM Standards (plates, hot rolled sections, hot finished and cold formed hollow sections, cold formed sections and profiled sheets)

Steel grade	Thickness less than or equal to (mm)	Design strength p_y (N/mm ²)
ASTM A36	200	250
	>200	220
ASTM A 572 Grade 50	All	345
ASTM A500 Grade B	All above 4.6 mm, Circular Hollow Sections	290
	All above 4.6 mm, Rectangular Hollow Sections	315
ASTM A992 Grade 50	All, Hot Rolled Shapes	345
ASTM A913 Grade 50	All, Quenched & Self Tempered	345
ASTM A913 Grade 60	All, Quenched & Self Tempered	415
ASTM A913 Grade 65	All, Quenched & Self Tempered	450

Note that a wide range of steel are available to American standards, see also references in Annex A1.1. This Table contains a summary range of strengths for easy reference. Refer to the particular ASTM material standard for that particular steel for its design strength value.

Table 3.5 - Design strength p_y for steels supplied in accordance with Australian standards (plates, hot rolled sections, hot finished and cold formed hollow sections, cold formed sections and profiled sheets)

Steel grade	Design strength range, dependant on thickness p_y (N/mm ²)
200	200
250	230 – 250
300	280 – 300
350	320 – 350
400	380 – 400
450	420 – 450

Note that a wide range of steel are available to Australian standards, see references in Annex A1.1. Plates, rolled sections and hollow sections are typically available with designated grades from 200 to 450 and with yield strengths from 200 N/mm² to 450 N/mm². This Table contains a summary range of strengths for easy reference. Refer to the particular Australian material standard for that particular steel for its design strength value.

Table 3.6 - Design strength p_y for Japanese JIS SN Steel (rolled steel for building products) to JIS G 3136 supplied in accordance with JIS standards (plates, hot rolled sections, hot finished and cold formed hollow sections, cold formed sections and profiled sheets)

Steel grade	Thickness less than or equal to (mm)	Design strength p_y (N/mm ²)
SN400A	16	235
	40	235
	100	215
SN400B	16	235
	40	235
	100	215
SN400C	16	235
	40	235
	100	235
SN490B	16	325
	40	325
	100	295
SN490C	16	325
	40	325
	100	295

Note that a wide range of steel are available to Japanese standards, see also references in Annex A1.1. This Table contains a summary range of strengths from the most recent SN range to JIS G 3136. Refer to the particular JIS material standard for that particular steel for its design strength value. Note that JIS G 3136 gives an upper limit to the steel yield strength which is applicable for seismic design.

3.1.3 Design strength for ultra high strength steels

For ultra high strength steels with a design strength greater than 690 N/mm² produced in accordance with the basic requirements in Annex D1.1, the design strength p_y may be taken as Y_s/γ_{m1} but not greater than U_s/γ_{m2} , where Y_s and U_s are respectively the minimum yield strength (R_{eH}) and minimum tensile strength (R_m) specified in the relevant reference material standard or derived by the manufacturer using an acceptable Quality Assurance system, while γ_{m1} and γ_{m2} are the material factors according to manufacturer's recommendations.

These materials typically obtain their strength through a quenching and tempering heat-treatment or a thermo-mechanically controlled process. There are additional restraints on fabrication and design, particularly with welding, because heat may affect the strength of the parent steel.

3.1.4 Uncertified steel

If Class 3 uncertified steel is used, it shall be free from surface imperfections and shall comply with all geometric tolerance specifications and shall be used only where the particular physical properties of the steel and its weldability will not affect the strength and serviceability of the structure. The design strength, p_y , shall be taken as 170 N/mm², subject to verification by testing as described in Annex D1.

The steel shall not be used in the primary structural elements of multi-storey buildings or in the primary structure of single storey buildings with long spans. Primary structural element is defined as main beams spanning directly onto columns, any beams over 6 m span, columns supporting a floor area of more than 25 m² or elements of lateral load resisting structural systems.

The steel shall only be used with elastic design methods for analysis and section capacity. The steel shall not be welded unless adequate tests on mechanical properties, chemical composition and hardness have demonstrated its suitability, see clause 3.1.2 and Annex D1.

3.1.5 Through thickness properties

The essential requirement is an adequate deformation capacity perpendicular to the plate surface to provide ductility and toughness against fracture under tension

The design strengths given in most material specifications refer to the longitudinal and transverse directions. Where there are through thickness tensile stresses greater than 90% of the design strength, through thickness properties as defined in acceptable references in Annex A1.1 should be specified to ensure structural adequacy. For thick T butt welds or for heavy double fillet welded joints, consideration should be given to specifying steel with guaranteed through thickness tensile properties to reduce the risk of lamellar tearing (see also clause 9.2.1).

The essential requirement is an adequate deformation capacity perpendicular to the surface to provide ductility and toughness against fracture.

3.1.6 Other properties

In carrying out the analysis, the following properties of steel may be used:

Modulus of elasticity	$E = 205,000 \text{ N/mm}^2$
Shear modulus	$G = E/[2(1+\nu)]$
Poisson's ratio	$\nu = 0.3$
Coefficient of linear thermal expansion	$\alpha = 14 \times 10^{-6}/^\circ\text{C}$
Density	7850 kg/m^3

3.2 PREVENTION OF BRITTLE FRACTURE

Brittle fracture should be avoided by ensuring fabrication is free from significant defects and by using a steel quality with adequate notch toughness as quantified by the Charpy

impact properties. The factors to be considered include the minimum service temperature, the thickness, the steel grade, the type of detail, the stress level and the strain rate.

The welding consumables and welding procedures should also be chosen to ensure the Charpy impact test properties in the weld metal and the heat affected zone of the joint that are equivalent to, or better than the minimum specified for the parent material, see clause 3.4 and clause 14.3.

In Hong Kong the minimum service temperature T_{min} in the steel should normally be taken as 0.1°C for external steelwork. For locations subject to exceptionally low temperatures, such as cold storage or structures to be constructed in other countries, T_{min} should be taken as the minimum temperature expected to occur in the steel within the design working life.

The guidance given in this section should be used for the selection of material for new construction. It is not intended to cover the assessment of materials in service. The rules should be used to select a suitable grade of steel from the steel products as listed in Annex A1.

The rules are applicable to tension elements, welded and fatigue stressed elements in which some portion of the stress cycle is tensile. Fracture toughness need not be specified for elements only in compression.

The rules shall be applied to the properties of materials specified for the toughness quality in the relevant steel product standard. Material of a less onerous grade shall not be used even though test results show compliance with the specific grade.

3.2.1 Procedure

3.2.1.1 The steel grade should be selected after taking account of:

- a) Steel material properties:
 - Yield strength depending on the material thickness $p_y(t)$
 - Toughness quality expressed in terms of T and J_{min}
where T is the temperature under Charpy impact test; and
 J_{min} is the guaranteed value of Charpy impact energy
- b) Member characteristics:
 - Member shape and detail
 - Element thickness (t)
- c) Design situations:
 - Design value of minimum service temperature, T_{min}
 - Maximum stress σ derived from the design condition described in clause 3.2.1.3 below
 - For cold-formed steel sections with significant transverse bending, for example, cold-formed circular and rectangular hollow sections, the minimum service temperature should be reduced by 5°C.

3.2.1.2 The permitted thickness of steel elements against brittle fracture should be obtained from clause 3.2.2 and Table 3.7.

3.2.1.3 The maximum stress σ derived of each structural element or connection should be determined by elastic analysis after considering various load combination including temperature effect under serviceability limit states in accordance with clause 4.3.7.

3.2.1.4 The maximum stress σ is determined using an elastic analysis under serviceability limit states.

3.2.2 Determination of maximum permissible values of element thickness

Table 3.7 gives the maximum permissible values of element thickness in terms of three stress levels expressed as proportions of the nominal yield strength:

- a) $\sigma = 0.75p_y(t)$ [N/mm²]
- b) $\sigma = 0.50p_y(t)$ [N/mm²]
- c) $\sigma = 0.25p_y(t)$ [N/mm²]

where $p_y(t)$ may be determined either from

$$p_y(t) = p_y - 0.25t \text{ [N/mm}^2\text{]}$$

where t is the thickness of the plate in mm or taken as

R_{eH} -values from the relevant steel material specifications or standards.

The tabulated values are given in terms of a choice of seven reference temperatures: +10, 0, -10, -20, -30, -40 and -50°C.

Table 3.7 Maximum permissible values of element thickness t in mm

Steel grade	Sub-grade		Delivery condition	Charpy impact energy		Minimum service temperature T_{min} [°C]																				
	EN	GBJ, ASTM, JIS, AS, NZ		at T [°C]	J_{min}	$\sigma = 0,75 p_y(t)$							$\sigma = 0,50 p_y(t)$							$\sigma = 0,25 p_y(t)$						
						10	0	-10	-20	-30	-40	-50	10	0	-10	-20	-30	-40	-50	10	0	-10	-20	-30	-40	-50
235	JR	B	As-rolled	20	27	60	50	40	35	30	25	20	90	75	65	55	45	40	35	135	115	100	85	75	65	60
	J0	C		0	27	90	75	60	50	40	35	30	125	105	90	75	65	55	45	175	155	135	115	100	85	75
	J2	D		-20	27	125	105	90	75	60	50	40	170	145	125	105	90	75	65	200	200	175	155	135	115	100
275	JR	B	As-rolled	20	27	55	45	35	30	25	20	15	80	70	55	50	40	35	30	125	110	95	80	70	60	55
	J0	C		0	27	75	65	55	45	35	30	25	115	95	80	70	55	50	40	165	145	125	110	95	80	70
	J2	D		-20	27	110	95	75	65	55	45	35	155	130	115	95	80	70	55	200	190	165	145	125	110	95
	M,N	B,C	TMCP / Normalized	-20	40	135	110	95	75	65	55	45	180	155	130	115	95	80	70	200	200	190	165	145	125	110
ML,NL	C,D	-50		27	185	160	135	110	95	75	65	200	200	180	155	130	115	95	230	200	200	200	190	165	145	
345, 350, 355	JR	B	As-rolled	20	27	40	35	25	20	15	10	65	55	45	40	30	25	25	110	95	80	70	60	55	45	
	J0	C		0	27	60	50	40	35	25	20	15	95	80	65	55	45	40	30	150	130	110	95	80	70	60
	J2	D		-20	27	90	75	60	50	40	35	25	135	110	95	80	65	55	45	200	175	150	130	110	95	80
	K2,M,N	B,C	TMCP / Normalized	-20	40	110	90	75	60	50	40	35	155	135	110	95	80	65	55	200	200	175	150	130	110	95
ML,NL	C,D	-50		27	155	130	110	90	75	60	50	200	180	155	135	110	95	80	210	200	200	200	175	150	130	
420	M,N	B,C	TMCP / Normalized	-20	40	95	80	65	55	45	35	30	140	120	100	85	70	60	50	200	185	160	140	120	100	85
	ML,NL	C,D		-50	27	135	115	95	80	65	55	45	190	165	140	120	100	85	70	200	200	200	185	160	140	120
460	Q	B,C	QT	-20	30	70	60	50	40	30	25	20	110	95	75	65	55	45	35	175	155	130	115	95	80	70
	M,N	B,C	TMCP	-20	40	90	70	60	50	40	30	25	130	110	95	75	65	55	45	200	175	155	130	115	95	80
	QL	C,D	QT	-40	30	105	90	70	60	50	40	30	155	130	110	95	75	65	55	200	200	175	155	130	115	95
	ML,NL	C,D	TMCP	-50	27	125	105	90	70	60	50	40	180	155	130	110	95	75	65	200	200	200	175	155	130	115
	QL1	D,E	QT	-60	30	150	125	105	90	70	60	50	200	180	155	130	110	95	75	215	200	200	200	175	155	130
550	Q	B,C	QT	0	40	50	40	30	25	20	15	10	80	65	55	45	35	30	25	140	120	100	85	75	60	50
	Q	B,C		-20	30	60	50	40	30	25	20	15	95	80	65	55	45	35	30	165	140	120	100	85	75	60
	QL	C,D		-20	40	75	60	50	40	30	25	20	115	95	80	65	55	45	35	185	160	140	120	100	85	75
	QL	C,D		-40	30	90	75	60	50	40	30	25	135	115	95	80	65	55	45	200	185	160	140	120	100	85
	QL1	D,E		-40	40	110	90	75	60	50	40	30	160	135	115	95	80	65	55	200	200	185	160	140	120	100
	QL1	D,E		-60	30	130	110	90	75	60	50	40	185	160	135	115	95	80	65	200	200	200	185	160	140	120
690	Q	B,C	QT	0	40	40	30	25	20	15	10	10	65	55	45	35	30	20	20	120	100	85	75	60	50	45
	Q	B,C		-20	30	50	40	30	25	20	15	10	80	65	55	45	35	30	20	140	120	100	85	75	60	50
	QL	C,D		-20	40	60	50	40	30	25	20	15	95	80	65	55	45	35	30	165	140	120	100	85	75	60
	QL	C,D		-40	30	75	60	50	40	30	25	20	115	95	80	65	55	45	35	190	165	140	120	100	85	75
	QL1	D,E		-40	40	90	75	60	50	40	30	25	135	115	95	80	65	55	45	200	190	165	140	120	100	85
	QL1	D,E		-60	30	110	90	75	60	50	40	30	160	135	115	95	80	65	55	200	200	190	165	140	120	100

Notes:

- Linear interpolation can be used in applying Table 3.7. Most applications require σ values between $0.75 p_y(t)$ and $0.5 p_y(t)$, and hence, $\sigma = 0.25 p_y(t)$ is given for interpolation purposes. Extrapolations between the extreme values are not valid.
- Table 3.7 has been derived from guarantee values of Charpy impact energy in the direction of the rolling of the product.
- Table 3.7 is also applicable for steel products supplied to other steel material specifications listed in Annex A1.1 with similar steel grades, i.e. having the same or similar minimum guaranteed values of Charpy impact energy.
- TMCP denotes the manufacturing process of thermo-mechanically controlled process corresponding to BS EN 10025-4.
- QT denotes the manufacturing process of quenching and tempering process corresponding to BS EN 10025-6.

3.3 BOLTS

3.3.1 Normal bolts

Bolts, nuts and washers shall comply with the requirements of the acceptable standards and references given in Annex A1.3.

Bolts with an ultimate tensile strength exceeding 1200 N/mm² should not be used unless test results demonstrate their acceptability in a particular design application.

3.3.2 High strength friction grip or preloaded bolts

High strength friction grip bolts, nuts and washers shall comply with the requirements of the reference standards given in Annex A1.3.

Requirements for the design of high strength friction grip bolted connections including tightening procedures are given in clause 9.3.

3.4 WELDING CONSUMABLES

All welding consumables shall conform to the requirements of the reference standards given in Annex A1.4. For steel with design strength not exceeding 690 N/mm² the specified yield strength, ultimate tensile strength, elongation at failure and Charpy impact value of the welding consumables shall be equal to or better than the corresponding values specified for the grade of steel being welded. The most onerous grade shall govern if dissimilar grades are welded together. For ultra-high strength steel, the welding consumables may, if necessary to produce a suitable joint, be of a lower strength; the elongation to failure and Charpy impact value should still match those of the parent material. In that case, the design strength of the weld must be based on the weld material.

3.5 STEEL CASTINGS AND FORGINGS

All steel castings and forgings shall comply with the requirements of the acceptable standards and references given in Annex A1.2.

3.6 MATERIALS FOR GROUTING OF BASEPLATES

Grout around foundation bolts and under column base plates should be one of the following forms:

Either a fluid Portland cement based grout comprising Portland cement and fine natural aggregate mixed in the ratio 1:1 by volume. The minimum amount of water is to be added to provide a viscosity suitable for the voids to be filled without bleeding or segregation of the fresh grout mix. The grout should be poured under a suitable head and tamped or vibrated to remove air pockets.

Or a proprietary non-shrink or resin based grout that does not contain high alumina cement.

3.7 MATERIALS FOR COMPOSITE CONSTRUCTION

Design for composite construction is covered in section 10. Materials used in composite construction other than steel are as follows:

3.7.1 Concrete

Concrete materials shall be in accordance with HKCC.

3.7.2 Reinforcement

Steel reinforcing bars and mesh materials shall be in accordance with HKCC.

3.7.3 Profiled steel sheets

Profiled steel sheets shall be in accordance with the requirements of the reference standards given in section 11.

3.7.4 Shear studs

Shear studs for composite construction shall be in accordance with the requirements of the reference standards given in Annex A1.6.

3.8 COLD-FORMED STEEL MATERIAL PROPERTIES

The material properties for cold formed steel open sections and sheet profiles as used in clauses 11.1 to 11.6 are given below. Acceptable references are given in Annex A1.7.

3.8.1 Mechanical properties

Both the yield strength (and hence the tensile strength) and the ductility of steel strips shall comply with the following:

3.8.1.1 Strength of steel

The design strength, p_y , is given by:

$$\begin{aligned} p_y &= \frac{Y_s}{\gamma_{m1}} \leq \frac{U_s}{\gamma_{m2}} && \text{when } Y_s < 460 \text{ N/mm}^2 \text{ for all steel thicknesses} \\ &= \frac{Y_s}{\gamma_{m1}} \leq \frac{U_s}{\gamma_{m2}} && \text{when } Y_s \geq 460 \text{ N/mm}^2 \text{ and } t > 1.0 \text{ mm} \\ &= \frac{Y_s}{\gamma_{m1}} \leq \frac{1.12 U_s}{\gamma_{m2}} && \text{when } Y_s \geq 460 \text{ N/mm}^2 \text{ and } t \leq 1.0 \text{ mm} \end{aligned} \quad (3.5)$$

where

Y_s is the yield strength, R_{eH}

which is defined as the stress at the initiation of yielding for steel materials with clearly defined yield point; or

0.2% proof stress, $R_{p0.2}$, or the stress at 0.5% total elongation, $R_{t0.5}$ for steel materials with no clearly defined yield point, whichever is smaller. In case of dispute, 0.2% proof stress, $R_{p0.2}$, shall be adopted.

U_s is the minimum tensile strength, R_m .

γ_{m1} , γ_{m2} are the material factors given in Table 4.1.

Table 3.8 summaries the yield and the tensile strengths of common cold-formed steel strips. The design strength, p_y , may be increased in Class 1 and Class 2 steel due to cold forming as given in clause 11.2.2.1.

For steel conforming to acceptable reference standards, the values of R_{eH} , $R_{p0.2}$, $R_{t0.5}$ and R_m should normally be taken as specified in the relevant product standard for the steel sheet or strip used for the formed sections.

3.8.1.2 Ductility requirements

In general, the total elongation shall be not less than 10% for a 50 mm gauge length or 7% for a 200 mm gauge length standard specimen tested in accordance with CS2.

Alternatively, the following criteria on local and uniform elongation may be adopted:

- (i) Local elongation in a 13 mm gauge length across the fracture should not be less than 20%.
- (ii) Uniform elongation outside the fracture should not be less than 3%.

In this case, the use of steel materials should be limited to members under lateral loads primarily, such as decking, sheeting and purlins. Moreover, no increase in design strength due to cold forming should be allowed.

3.8.1.3 *High strength steel strips with limited ductility*

For high strength S550 steel strips that failed to comply with the ductility requirements listed in clause 3.8.1.2, the use of steel materials should be limited to members under lateral loads primarily, and the design yield strength should be reduced as follows:

$$p_y = 0.90 Y_s \text{ or } 495 \text{ N/mm}^2 \quad (\text{whichever is lesser}) \quad \text{when } t \leq 1.0 \text{ mm}$$

$$= 0.75 Y_s \text{ or } 450 \text{ N/mm}^2 \quad (\text{whichever is lesser}) \quad \text{when } t \leq 0.6 \text{ mm}$$

Moreover, no increase in design strength due to cold forming should be allowed.

Table 3.8 - Yield and tensile strengths for steels supplied in accordance with various national standards

Type of steel	Grade	Yield strength Y_s (N/mm ²)	Tensile strength U_s (N/mm ²)
British standard: BS EN 10025 Hot rolled steel sheet of structural quality	S235	235	360
	S275	275	430
	S355	355	510
British standard: BS EN 10147 Continuous hot dip zinc coated carbon steel sheet of structural quality	S220 G	220	300
	S250 G	250	330
	S280 G	280	360
	S320 G	320	390
	S350 G	350	420
British standard: BS EN 10149-2 & 3 High yield strength steels for cold forming	S315 MC	315	390
	S355 MC	355	430
	S420 MC	420	480
	S260 NC	260	370
	S315 NC	315	430
	S355 NC	355	470
	S420 NC	420	530
British standard: BS EN 10268 Cold-rolled steel flat products with high yield strength for cold forming – Technical delivery conditions	34/20	200	340
	37/23	230	370
	43/25	250	430
	50/35	350	500
	40/30	300	400
	43/35	350	430
	40F30	300	400
	43F35	350	430
Australia standard: AS 1397 Steel sheet and strip	G250	250	320
	G300	300	340
	G350	350	420
	G450	450	480
	G500	500	520
	G550	550	550
Chinese standard: GB 50018 Technical code of cold-formed thin-wall steel structures	Q235	205	-
	Q345	300	-

Table 3.8 - Yield and tensile strengths for steels supplied in accordance with various national standards (continued)

Type of steel	Grade	Yield strength Y _s (N/mm ²)	Tensile strength U _s (N/mm ²)
Japanese standard: JIS G 3302 Hot-Dip Zinc-Coated Steel Sheets and Coils	SGC340	245	340
	SGC400	295	400
	SGC440	335	440
	SGC490	365	490
	SGC570	560	570
Japanese standard: JIS G 3312 Prepainted Hot-Dip Zinc- Coated Steel Sheets and Coils	CGC340	245	340
	CGC400	295	400
	CGC440	335	440
	CGC490	365	490
	CGC570	560	570
Japanese standard: JIS G 3321 Hot-Dip 55 % Aluminium-Zinc Alloy-Coated Steel Sheets and Coils	SGLCC	205	270
	SGLC400	295	400
	SGLC440	335	440
	SGLC490	365	490
	SGLC570	560	570
Japanese standard: JIS G 3322 Prepainted Hot-Dip 55 % Aluminium-Zinc Alloy-Coated Steel Sheets and Coils	CGLCC	205	270
	CGLC400	295	400
	CGLC440	335	440
	CGLC490	365	490
	CGLC570	560	570
American standard: ASTM A308(M) Standard Specification for Steel Sheet, Terne (Lead-Tin Alloy) Coated by the Hot-Dip Process	Grade 170	170	290
	Grade 205	205	310
	Grade 230	230	330
	Grade 275	275	360
	Grade 550	550	565
American standard: ASTM A653(M) Standard Specification for Steel Sheet, Zinc-Coated (Galvanized) or Zinc-Iron Alloy-Coated (Galvannealed) by the Hot-Dip Process	Grade 230	230	310
	Grade 255	255	360
	Grade 275	275	380
	Grade 340	340	450
	Grade 550	550	570
American standard: ASTM A792(M) Standard Specification for Steel Sheet, 55 % Aluminium-Zinc Alloy-Coated by the Hot-Dip Process	Grade 230	230	310
	Grade 255	255	360
	Grade 275	275	380
	Grade 340	340	450
	Grade 550	550	570

4 LOAD FACTORS AND MATERIAL FACTORS

4.1 PARTIAL SAFETY FACTORS

In limit state design, both cross section capacity and member resistance should be checked against material yielding and structural instability respectively, and various load and material partial safety factors are incorporated for different modes of failure and limit states.

Ultimate design loads or factored loads Q_{ult} are obtained by multiplying characteristic loads Q_{char} by a partial load factor γ_f :

$$Q_{ult} = \gamma_f Q_{char}$$

Design load effects S_{ult} , for example bending moments, are obtained from design loads by the appropriate design calculation:

$$S_{ult} = f(\text{effects of } Q_{ult})$$

The partial load factor γ_f allows for variation of loads from their characteristic (i.e. assumed working) values, for the reduced probability that various loads acting together will reach their characteristic values and for inaccuracies in calculation and variations in structural behaviour.

Ultimate design resistance R_{ult} is calculated from dividing characteristic or specified material strengths by a partial material factor γ_{m1} to allow for manufacturing tolerances and variations of material strengths from their characteristic values.

$$R_{ult} = f(Y_s/\gamma_{m1} \text{ but } \leq U_s/\gamma_{m2})$$

For satisfactory design of an element at ultimate limit states, the design resistance R_{ult} must be greater than or equal to the design load effects S_{ult} :

$$R_{ult} > S_{ult}$$

For satisfactory design of an element at serviceability limit states, the same rationale applies with changed values for the load factors, typically values of load factors for serviceability calculations are 1.0. The material factor on properties such as Young's modulus is 1.0.

4.2 MATERIAL FACTORS

4.2.1 Steel plates and sections

For strength design of normal strength **Class 1** steel plates, sections and weldable castings supplied in accordance with the essential requirements or reference standards given in Annex A1.1 of the Code, the recommended minimum partial material factor γ_{m1} shall be 1.0.

Normal strength **Class 2** steel from a known source which does not comply with the specification requirements in Annex A1.1 of the Code shall be tested and if found to comply should also be used with a material factor γ_{m1} of 1.1

Strength design of **Class 3** steel plates, sections and weldable castings from an unknown source shall comply with clause 3.1.4. Such materials shall only be used for minor structural elements where the consequences of failure are limited.

For high strength **Class 1H** steel plates and sections with a yield stress greater than 460 N/mm² but less than or equal to 690 N/mm² and complying with one of the reference material standards in Annex A1.1, the partial material factors are given in Table 4.1.

For ultra high strength **Class UH** steel plates and sections with a yield stress greater than 690 N/mm² and complying with one of the reference material standards in Annex 1.1, the partial material factor should refer to manufacturer's recommendations.

Table 4.1 - Material factors γ_{m1} and γ_{m2} for various classes of steels

Class	$Y_s \leq 460 \text{ N/mm}^2$		$460 < Y_s \leq 690 \text{ N/mm}^2$	
	γ_{m1}	γ_{m2}	γ_{m1}	γ_{m2}
1	1.0	1.1	-	-
2	1.1	1.2	-	-
3	*	*	-	-
1H	-	-	1.0	1.05

Notes: These factors for γ_{m1} and γ_{m2} are minimum values to be used and the design strength for particular steel shall not be greater than that of the relevant national material standard as given in clauses 3.1.2. & 3.1.3 or reference published data.

* For Class 3 steel p_y is limited to 170 N/mm² and ultimate tensile strength to 300 N/mm²

4.2.2 Bolts

Design strengths for bolts, which implicitly include partial materials factors in different design situations, are given in clause 9.3.

4.2.3 Reinforcement and concrete in composite design

For strength design of composite sections, the partial materials factors for reinforcing steel and concrete shall comply with clause 2.4.3 of the HKCC.

4.2.4 Grout for base plates and wall plates

Material factors for cement grout for base plate connections, for steel plate to concrete wall connections and for grouting in holding down bolts and anchors shall comply with clause 4.2.3 above, i.e. the ultimate design values for bearing, bond and shear stresses for grout should be the same as for concrete of equivalent cube strength f_{cu} .

4.3 LOAD FACTORS AND COMBINATIONS

The various types of load to which a structure may be subjected are given in clause 2.5. The following principal combinations of loads should be taken into account:

Load combination 1: Dead load, imposed load (and notional horizontal forces)

Load combination 2: Dead load and lateral load

Load combination 3: Dead load, imposed load and lateral load

4.3.1 Load combinations for normal ultimate limit state

The load factors and combinations given in Table 4.2 apply to strength and stability for normal design situations.

Table 4.2 - Partial load factors and combinations for normal condition design

Load combination (including earth, water and temperature loading where present)	Load Type						
	Dead		Imposed		Earth and water	Wind	Temperature
	G_k		Q_k		S_n	W_k	T_k
	Adverse	Beneficial	Adverse	Beneficial			
1. dead and imposed	1.4	1.0	1.6	0	1.4	-	1.2
2. dead and lateral	1.4	1.0	-	-	1.4	1.4	1.2
3. dead, lateral and imposed	1.2	1.0	1.2	0	1.2	1.2	1.2

Where the action of earth or water loads can act beneficially, the partial load factor should not exceed 1.0. (The value of the partial load factor γ_f should be taken such that $\gamma_f \times$ the design earth or water load equals the actual earth or water loads)

Where differential settlement is required to be considered, a partial load factor of 1.4 shall be used in combinations 1 and 2 and a partial load factor of 1.2 shall be used in combination 3.

Where collision loads are required to be considered as part of normal design, they shall be treated as imposed loads with the appropriate safety factor.

4.3.2 Load combinations for overhead traveling cranes

Overhead traveling cranes exert vertical and horizontal loads which should be considered with other loads. Details of load factors and loads arising from overhead cranes are given in clause 13.7.

4.3.3 Load combinations for building assessment

Refer to section 17 of the Code. The values of partial load factor given in Table 4.2 shall be used unless lower values can be justified. The minimum value of any load factor acting adversely should be 1.2.

4.3.4 Load combinations for temporary works in construction

The values in Table 4.2 should be used if it is considered that the consequence of failure of a particular element are not serious enough to warrant a higher load factor. In no circumstances should any adverse load factor be less than 1.2. This includes load factors for wind loads.

4.3.5 Load combinations for exceptional events

Exceptional load cases can arise either from an exceptional load such as a vehicle collision or explosion or from consideration of the remaining structure after removal of a key element.

Table 4.3 contains the load factors to be used in these situations and take account of the probability of other loads acting in combination with the exceptional event.

For fire resistant design, separate partial factors should be applied, see clause 12.1.5.

Table 4.3 - Partial load factors and combinations for extreme events

Load combination (including earth, water loading where present)	Load Type						
	Dead		Imposed		Earth and water	Wind	Extreme Event
	G_k		Q_k		S_n	W_k	A_k
	Adverse	Beneficial	Adverse	Beneficial			
1. dead, imposed and extreme event	1.05	1.0	0.35	0	1.05	-	1.0
2. dead, lateral and extreme event	1.05	1.0	-	-	1.05	0.35	1.0
3. dead, lateral, imposed and extreme event	1.05	1.0	0.35	0	1.05	0.35	1.0

Where the action of earth or water loads can act beneficially, the partial load factor should not exceed 1.0. (The value of the partial load factor γ_f should be taken such that $\gamma_f \times$ the design earth or water load equals the actual earth or water load). Where differential settlement or temperature effects are required to be considered, a partial load factor of 1.05 shall be used in combinations 1, 2 and 3.

For buildings used for storage or industrial purposes or where the imposed loads are permanent, the adverse partial load factors for imposed load for extreme events shall be taken as 1.0.

4.3.6 Summary of partial load factors

The following Table 4.4 summarises the various partial load factors used in the preceding sections.

Table 4.4 - Summary of partial load factors for ultimate limit state

Type of load and load combination	Factor γ_f
Dead load, except as the following.	1.4
Dead load acting together with lateral load and imposed load combined.	1.2
Dead load acting together with crane loads and imposed load combined.	1.2
Dead load acting together with crane loads and lateral load combined.	1.2
Dead load acting together with extreme event load.	1.05
Dead load whenever it counteracts the effects of other normal loads.	1.0
Dead load when it counteracts extreme event load.	1.0
Dead load when restraining sliding, overturning or uplift.	1.0
Imposed load except as the following.	1.6
Imposed load acting together with wind load.	1.2
Imposed load acting together with extreme event load.	0.35
Wind load.	1.4
Extreme event load.	1.0
Wind load acting together with imposed load.	1.2
Storage tanks, including contents.	1.4
Storage tanks, empty, when restraining sliding, overturning or uplift.	1.0
Earth and ground water load, nominal values.	1.4
Earth and ground water load, acting beneficially.	≤ 1.0
Exceptional snow load, for cold regions, caused by local drifting on roofs.	1.05
Forces caused by temperature change.	1.2
Forces caused by differential settlement.	1.4
Forces caused by differential settlement together with imposed and wind loads.	1.2
Vertical crane loads.	1.6
Vertical crane loads acting together with horizontal crane loads.	1.4
Horizontal crane loads from surge or crabbing, see clause 13.7.	1.6
Horizontal crane loads acting together with vertical crane loads.	1.4
Vertical crane loads acting together with imposed load.	1.4
Horizontal crane loads acting together with imposed load.	1.2
Imposed load acting together with vertical crane loads.	1.4
Imposed load acting together with horizontal crane loads.	1.2
Crane loads acting together with wind load.	1.2
Wind load acting together with crane loads.	1.2
Vertical crane loads acting beneficially to counteract other loads.	1.0

Notes: (a) "Wind" load includes minimum lateral load of 1.0% of dead load.

(b) Extreme event loads are treated as ultimate loads.

4.3.7 Load combinations for serviceability limit states

For the serviceability limit state it is generally sufficient to use a load factor of 1.0 for dead, live and wind loads, i.e. to use the working or characteristic values of the loads.

A load factor of 1.0 should also be used when it is necessary to consider other effects causing movement such as differential settlement and temperature change.

5 SERVICEABILITY LIMIT STATES

5.1 GENERAL

A structure shall be designed and constructed to meet relevant serviceability criteria in clauses 5.2 to 5.4. The checking should be based on the most adverse realistic combination and arrangement of serviceability loads and the structure is assumed to behave elastically.

5.2 DEFLECTION

The deflections or deformations from all load types should not impair the strength or effective functioning of a structure, supporting elements or its components, nor cause damage to the finishes. For typical structures, the deflection limits in Table 5.1 are recommended. Precamber in an unloaded structural member may be used to reduce the calculated deflection of that member under the loading conditions.

Table 5.1 - Deflection limits

a) Deflection of profiled steel sheeting	
Vertical deflection during construction when the effects of ponding are not taken into account	Span/180 (but ≤ 20 mm)
Vertical deflection during construction when the effects of ponding are taken into account	Span/130 (but ≤ 30 mm)
Vertical deflection of roof cladding under dead and wind load	Span/90 (but ≤ 30 mm)
Lateral deflection of wall cladding under wind load	Span/120 (but ≤ 30 mm)
b) Vertical deflection of composite slab	
Due to imposed load	Span/350 (but ≤ 20 mm)
Due to the total load plus due to prop removal (if any) less due to self-weight of the slab	Span/250
c) Vertical deflection of beams due to imposed load	
Cantilevers	Length/180
Beams carrying plaster or other brittle finish	Span/360
Other beams (except purlins and sheeting rails)	Span/200
Purlins and sheeting rails	To suit cladding
d) Horizontal deflection of columns due to imposed load and wind load	
Horizontal drift at topmost storey of buildings	Height/500
Horizontal drift at top of a single storey portal not supporting human	To suit cladding
Relative inter-storey drift	Storey height/400
Columns in portal frame buildings	To suit cladding
Columns supporting crane runways	To suit crane runway
e) Crane girders	
Vertical deflection due to static vertical wheel loads from overhead traveling cranes	Span/600
Horizontal deflection (calculated on the top flange properties alone) due to horizontal crane loads	Span/500
f) Trusses	
Typical trusses not carrying brittle panels	Span/200

Note:

Exceedance of the above limit is not acceptable unless a full justification is provided.

Precamber deflection can be deduced in the deflection calculation.

Ponding should nevertheless be avoided in all cases.

Long span structures should be checked against vibration.

5.3 WIND INDUCED VIBRATION

Vibration of a structure should be limited to avoid discomfort to users and damage to contents. For special structures, including long-span bridges, large stadium roofs and chimneys, wind tunnel model tests are recommended for their wind resistant design to meet serviceability limits.

5.3.1 Wind sensitive buildings and structures

A design procedure which incorporates dynamic analysis in addition to static analysis shall be undertaken for wind sensitive buildings and structures. Structures with low natural frequency or large height-to-least dimension ratio should receive special checking. Reference should be made to the Code of Practice on Wind Effects in Hong Kong.

For slender, flexible and lightly damped tall buildings and structures, those with a long afterbody or complex geometry, and those with an eccentricity between mass and stiffness centres, aeroelastic instabilities such as lock-in, galloping and flutter may cause large amplitude crosswind responses. Specialist advice and wind tunnel model test are recommended for their wind resistant design to meet serviceability limits.

5.3.2 Serviceability limit state

The serviceability limit states on vibration, deflection and acceleration should be checked to ensure serviceable condition for the structure.

5.3.3 Dynamic structural characteristics

5.3.3.1 *Natural frequencies*

Structural analysis programmes should be used to determine the natural frequencies of vibration of buildings and structures to mitigate excessive horizontal and vertical vibration. Empirical formulae can also be used for approximated vibration analysis of typical and regular buildings.

5.3.3.2 *Structural damping*

The structural damping value for steel buildings and structures is amplitude dependent and varies greatly depending on the type of structure and the structural layout. When structural damping is required to enhance serviceability limit state, published data on damping ratio for various types of structures may be used with justification. Clauses below cover common structural forms while special structures should be referred to specialist literature.

5.3.4 Serviceability criteria for tall buildings

Generally the maximum wind load and deflection occurs along an axis in the along-wind direction although the cross-wind response may dominate in the case of certain tall and slender structures. For such tall and slender structures (typically with an aspect ratio of 5:1 or greater), occupant discomfort due to building motion may be an issue during severe typhoons. Torsional effects and eccentricity between centres of building mass and stiffness can affect building response to wind.

Excessive deflection may cause cracking of masonry, partitions and other interior finishes and building façade. Whilst the maximum lateral deflection shall not exceed the values given in Table 5.1, (Topmost storey deflection limited to Height / 500 and inter storey drift limited to Storey height / 400) the design and detailing of cladding, curtain walling, partitions and finishes should take into account the effects of deflection, inter storey drift and movement.

Alternatively, a dynamic serviceability analysis and design may be carried out to justify compliance with serviceability limit for tall buildings. In such a case:

- a) It should be recognised that excessive deflection may cause cracking of masonry, partitions and other interior finishes and the design and detailing of cladding, curtain walling, partitions and finishes should take into account the effects of deflection, inter-storey drift and movement.

- b) A dynamic analysis to study building motion, frequency of vibration and acceleration should be carried out. Acceptable levels of occupant comfort will be considered to have been achieved in compliance with the Code if the following building acceleration limits during the worst 10 consecutive minutes of an extreme wind event with a return period of 10 years are met:

Type of Use of Building	Peak acceleration (milli-g)
Residential	15
Office building, Hotel	25

The **10-year** return period of **10-minute** wind speed may be determined from suitable analysis of Hong Kong wind climate data, numerical typhoon modelling or derived from the wind speed used for strength design.

It should be noted that for some buildings, a higher degree of occupant comfort may be desirable. The above only represents an acceptable minimum standard for most buildings. Local researchers and published standards, e.g. ISO 6897 indicates that peak acceleration as comfort criteria is frequency dependent.

- c) Occupant tolerance of motion is influenced by many factors including experience, expectation, frequency of building motion, frequency of exposure, and visual and audio cues. As an alternative to the above guidelines in (b) performance based assessments may be carried out to justify the design. Such a performance-based approach would normally include comprehensive wind tunnel testing.

Excessive acceleration under wind loads should always be avoided. Limiting deflection at the topmost storey of a building to $H / 500$ under the design wind load specified in the HKWC will usually provide an acceptable environment for occupants in most typical buildings without the need for a dynamic analysis. However, the Responsible Engineer should always consider each building on its merits.

For other types of structures, specialist advice should be sought.

5.3.5 Serviceability criteria for communication and broadcasting towers

Communication and broadcasting services demand minimal disruption to transmission. The serviceability limits for communication and broadcasting towers are selected to meet the performance specifications of antennae and other transmission devices to be mounted on those towers. Excessive vibration of towers should be avoided. For design, reference should be made to specialist literature.

5.3.6 Reduction of wind induced dynamic response

If the calculated deflection or acceleration exceeds the serviceability limits, mitigation methods including but not limited to (a) increasing mass (i.e. frequency dependent mitigation method), (b) increasing stiffness, (c) increasing damping and (d) altering the aerodynamic shape may be used. Specialist advice should be sought when changing mass, stiffness, damping and/or aerodynamic shape is needed for reducing wind-induced response.

5.4 HUMAN INDUCED FLOOR VIBRATION

When the deflection limit for beams and floors are exceeded, it may be necessary to check the vibration of the members for human comfort. For light weight and long span structures as well as vibration suspected occupancies (such as dancing hall, aerobics, and factory, etc.), where excessive vibration is anticipated, floor vibration assessment may be necessary. Reference should be made to relevant Code of Practices and specialist literature as given in Annex A2.5.

5.5 DURABILITY

5.5.1 General

Steelwork can be subjected to many different degrees of environmental exposure. This section provides general guidance for steelwork in building and some other structures subjected to more commonly occurring exposure conditions.

The following factors should be taken into account in design of protective systems for steelwork in order to ensure the durability of the structure under conditions relevant both to its intended use and to its design working life.

- a) The environment of the structure, whether bimetallic corrosion is possible and the degree of exposure of the structure.
- b) Accessibility of structure for inspection and maintenance, (i.e. easy, difficult or impossible). Access, safety and the shape of the members and structural detailing are relevant.
- c) The relationship of the corrosion protection and fire protection systems.

The purpose of this section is to provide general guidance on corrosion protection. It is not an attempt to prescribe particular solutions in detail. Detailed guidance on corrosion protection can be found in specialist literature.

Refer to clause 13.8 for guidance on maintenance.

5.5.1.1 *Typical exposure conditions*

Typical examples of commonly occurring exposure conditions are given below.

Table 5.2 - Exposure conditions

Exposure Class	Type of Exposure	Examples
1	Non corrosive	Steelwork in an internal controlled (i.e. dry) environment. Steel piles driven into undisturbed and non-corrosive ground.
2	Mild (typically internal)	Steelwork in an internal humid environment.
3	Moderate (internal or external)	Steelwork built into perimeter cladding. External steelwork in a dry climate.
4	Severe	External steelwork exposed to rain and humidity. Internal steelwork over a swimming pool, kitchen or water tank.
5	Extreme	External steelwork in a marine environment. Steel piles driven into corrosive ground. Steelwork exposed to salt water.

5.5.1.2 *Maintenance regime*

The degree of maintenance to be carried out to the protective system depends not only on the client's requirements for initial cost versus ongoing maintenance cost but also on the accessibility of the steelwork for carrying out the maintenance.

Three classes for accessibility of maintenance are defined here:

Class A: Good access i.e. easily accessible and / or will be regularly maintained.

Class B: Poor access i.e. difficult to access and will be infrequently maintained.

Class C: Extremely difficult or impossible access for maintenance.

5.5.2 Types of protection against corrosion

Systems for various levels of corrosion protection are described in this section. A guide to

their applicability is given in Table 5.3 below. All relevant information including the proposed maintenance regime shall be considered before selecting an appropriate system. Refer to clause 14.6 for protective treatment workmanship.

Table 5.3 - Types of protective system and typical application guide

Type of protection system	Exposure class	Minimum recommended class for accessibility of maintenance
None, i.e. bare steel,	1	Not applicable
Use of paint systems as protective coatings.	2, 3, 4	B
Paint and cementitious or sprayed fibre fire protection	1, 2	B
Encasement in concrete. (also provides structural composite action)	1, 2, 3, 4, possibly 5	C
Use of galvanized or metal sprayed protective coatings.	3, 4	C
Use of a corrosion resistant alloy e.g. stainless steel or weathering steel	3, 4, 5	C
Use of a sacrificial corrosion allowance	4, 5	C
Use of Cathodic Protection (CP)	5	B

5.5.2.1 Galvanizing

Hot dip galvanizing should comply with the requirements of the applicable standards and be at least 85 microns thick.

The high temperature of the galvanizing process can lead to distortions as locked-in stresses are relieved.

Bolts of ISO Grade 10.9 or higher grade or equivalent should not be galvanized, but should be sheradized and coated with zinc-rich or appropriate protective paint.

Hollow sections should be vented if they are to be galvanized.

Some high strength steels with yield strength greater than 460 N/mm² may be sensitive to cracking during galvanization and therefore special care should be taken. Hence, suitable venting should be provided while special dipping procedures shall be executed in order to alleviate the risk of cracking and distortion.

BS EN ISO 14713-2 has provided further guidance, including information on the influence of various factors, including steel chemical composition, on the coating formation.

5.5.2.2 Concrete casing

Concrete casing shall be reinforced with wrapping fabric e.g. D49 as a minimum. Cover shall be as required for fire protection but should not be less than 50 mm for practical reasons of compaction. Small sized aggregate may be required.

If the casing is required to act compositely with the steel to transfer significant shear stresses (over 0.1 N/mm²), then the steel shall be blast cleaned to remove mill scale before casing.

5.5.2.3 Paint systems

A suitable paint system should be selected using one of the references given or manufacturer's guidance. Regular maintenance of paint protection systems shall be carried out.

5.5.2.4 Minimum thickness of permanent steelworks without special protection against corrosion

Steel plates and rolled sections used in an external environment exposed to the weather i.e. exposure classes 3, 4 and 5, shall not be less than 8 mm thick. Steel used in an internal

environment, i.e. exposure classes 1 and 2, shall not be less than 6 mm thick. (Except packing plates which may be thinner.)

Sealed hollow sections in exposure classes 3, 4 and 5 shall not be less than 4 mm thick and for exposure classes 1 and 2 shall not be less than 3 mm thick.

These minimum thicknesses may not apply to particular proprietary products and in such a case, the Responsible Engineer shall provide justification that the corrosion resistance of the product is suitable for its application. Under all circumstances, the minimum thickness for all structural members shall not be less than 3 mm.

Cold formed steel protected by a factory applied barrier against corrosion shall not be less than 0.5 mm thick.

5.5.2.5 *Sacrificial corrosion allowances for steel*

Where other forms of protection are not practical, a sacrificial corrosion allowance may be made for steelwork in exposure classes 4 and 5. In such cases, the sacrificial allowance for corrosion shall be made in addition to the minimum thickness obtained from calculations for structural strength and stability.

The sacrificial thickness shall be determined from the particular corrosion regime and required life of the structural element under consideration. As a guide, an allowance of 0.25 mm to 0.5 mm per year may be considered.

5.5.3 Corrosion from residual stresses

Corrosion normally occurs severely at locations where there are significant residual stresses inherent in the steel during fabrication (cold working) and welding, for example from cambering, curving and straightening. Corrosion protection by painting or galvanizing, adoption of sacrificial thickness philosophy or other effective measures can be taken to improve the corrosion resistance of the material.

To relieve residual stresses, post-weld heat treatment with 600°C to 650°C of heat applied to a region between 150 mm to 300 mm around the subject location may be considered when applicable.

6 DESIGN METHODS AND ANALYSIS

6.1 METHODS OF ANALYSIS

Second-order effects should be included in an analysis unless they can be proven to be insignificant. The $P-\Delta$ and the $P-\delta$ effects should be considered either in the analysis or in the design stage depending upon analysis method used.

The internal forces and moments acting on a structure may be calculated by one of the following analysis methods:

- (1) Simple design, lateral forces taken by linked rigid structure and beams are assumed simply supported on columns (see clause 6.5);
- (2) First-order linear elastic analysis, using the original and undeformed geometry of the structure (see clause 6.6);
- (3) Second-order elastic $P-\Delta$ -only analysis, allowing for the effects of deformation of the structure (see clause 6.7);
- (4) Second-order elastic $P-\Delta-\delta$ analysis, allowing for the effects of deformation of the structure and the bowing deflection of members (see clause 6.8); and
- (5) Advanced analysis allowing for the effect of deformation of the structure and members and material yielding (see clause 6.9).

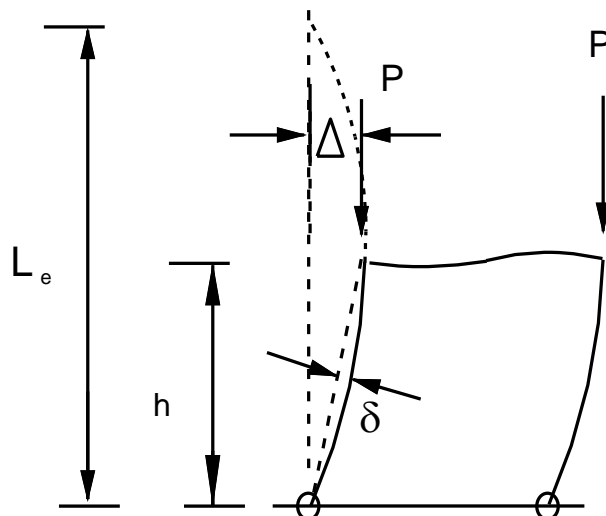

Figure 6.1 - Column effective length, $P-\Delta$ and $P-\delta$ moments

Both the $P-\Delta$ and $P-\delta$ effects with allowance for their initial imperfections must be allowed for either in the global analysis or in the design stage using clause 8.9.2.

The resistance of a structure is limited to the first plastic hinge for Class 1 plastic and Class 2 compact sections or to first yield for Class 3 semi-compact and Class 4 slender sections in methods (1) to (4), but to the elastic-plastic collapse load for method (5). Methods (3) and (4) are based on the large deflection analysis without and with allowance for member bow. Moment or force re-distribution due to material yielding is not allowed. Only Class 1 plastic and Class 2 compact sections can be used in method (5) with only Class 1 plastic section used for members possessing plastic hinges.

Static equilibrium, resistance to notional horizontal forces and sway stiffness should be checked using relevant and the most unfavourable and realistic load factors and combinations of load cases.

Superposition of moments and forces are allowed only in simple design and first-order linear elastic analysis methods.

Local member buckling effects due to flexural-torsional, torsional, and local plate buckling should be checked separately on a member basis, unless these effects have already been accounted for in the analysis or demonstrated to be negligible.

6.2 ANALYSIS MODELS AND ASSUMPTIONS

A suitable analysis model and consistent assumptions should be used to simulate the actual structural behaviour. The design of members and connections should accord with the analysis assumptions and not adversely affect the structural adequacy of other parts of the structure. All structures should be designed to have an adequate level of robustness against the effects of applied loadings and notional horizontal forces. Further, they should have sufficient sway stiffness and member stiffness to avoid the vertical loads producing excessive second-order P- Δ and P- δ effects. When this P- Δ effect is significant, it should be allowed for in column buckling strength, connection and beam design. The second-order P- δ effect should be considered for compression members.

The effective length of sloping members, inclined roofs and rafters under large axial forces may involve snap-through buckling and ambiguity in classifying the member as a beam or a column in effective length determination using charts. In such cases, the effective length cannot be determined by simple charts and second-order analysis or advanced analysis shall be used.

Ground-structure interaction can be considered by assuming the nominally rigid ground support to have stiffness equal to the column stiffness or to be pinned in other cases unless an assessment shows a more appropriate value of ground stiffness can be used.

6.3 FRAME CLASSIFICATION

6.3.1 General

Sway stiffness of a frame affects its buckling strength. The elastic critical load factor λ_{cr} determined in clause 6.3.2 can be used to classify a frame as sway, non-sway and sway ultra-sensitive frame for the following purposes.

- (1) Measure of sway stability for frame classification in this section and
- (2) Determination of moment amplification in clause 6.6.2

Frame classification can be carried out by calculating the elastic critical load factor λ_{cr} which can be obtained either by the eigenvalue analysis for general structures or the deflection method for geometrically regular and rectangular frame as described in clause 6.3.2.

6.3.2 Elastic critical load factor

6.3.2.1 General

Elastic critical load factor λ_{cr} can be obtained by the eigenvalue analysis or by the deflection method below. λ_{cr} of a frame is defined as the ratio by which the factored loads would have to be increased to cause elastic instability. Member imperfection is not required for frame classification.

6.3.2.2 Deflection method

For sway buckling mode of a geometrically regular and rectangular frame subjected to gravitational loads or gravitational loads plus horizontal load (e.g. wind), the elastic critical load factor λ_{cr} for a sway frame as shown in Figure 6.2 may be calculated as the smallest value for every storey with drift determined from the first-order linear analysis as,

$$\lambda_{cr} = \frac{F_N}{F_V} \frac{h}{\delta_N} \quad (6.1)$$

where F_V is the factored Dead plus Live loads on the floor considered;
 F_N is the notional horizontal force taken typically as 0.5% of F_V for building frames;
 h is the storey height; and
 δ_N is the notional horizontal deflection of the upper storey relative to the lower storey due to the notional horizontal force F_N .

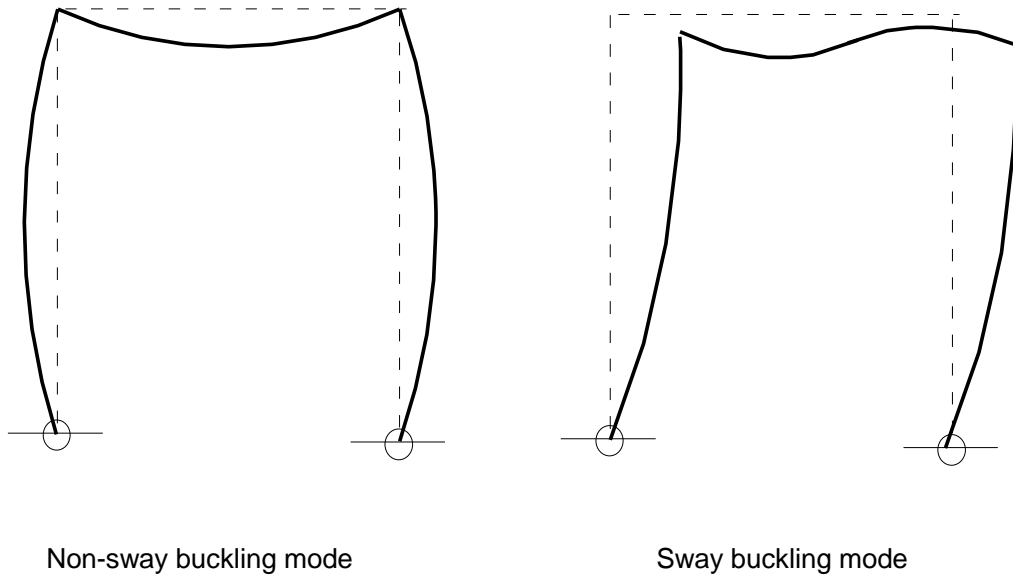

Figure 6.2 Sway and Non-sway buckling modes

For non-rectilinear frame, the elastic critical load factor λ_{cr} can be obtained by the eigenvalue analysis. For single portal frame, the designer should refer to clause 8.11.

6.3.3 Non-sway frames

Except for advanced analysis, a frame is classified as non-sway and the P- Δ effect can be ignored when

$$\lambda_{cr} \geq 10 \tag{6.2}$$

For advanced analysis, a frame is classified as non-sway and the P- Δ effect can be ignored when

$$\lambda_{cr} \geq 15 \tag{6.3}$$

6.3.4 Sway frames

Except for advanced analysis, a frame is classified as sway when

$$10 > \lambda_{cr} \geq 5 \tag{6.4}$$

For advanced analysis, a frame is classified as sway when

$$15 > \lambda_{cr} \geq 5 \tag{6.5}$$

6.3.5 Sway ultra-sensitive frames

A frame is classified as sway ultra-sensitive when

$$\lambda_{cr} < 5 \tag{6.6}$$

Only second order P- Δ - δ or advanced analysis can be used for sway ultra-sensitive frames.

6.4 IMPERFECTIONS

6.4.1 General

In an analysis for members in compression or frames with members in compression, suitable allowance should be made for imperfections either in the analysis stage or in the design stage. Imperfections are due to geometrical and material effects and should be simulated by using suitable and equivalent geometrical imperfections.

Appropriate equivalent geometric imperfections may be used with suitable amplitudes and modes reflecting the combined effects of all types of imperfections.

The effects of imperfections shall be taken into account when considering the following:

- 1) Frame analysis
- 2) Member design
- 3) Bracing members

6.4.2 Frame imperfections

The effects of imperfections for typical structures shall be incorporated in frame analysis using an equivalent geometric imperfection in Equation 6.7 as an alternative to the notional horizontal force in clause 2.5.8,

$$\Delta = h / 200 \quad (6.7)$$

where

h is the storey height;

Δ is the initial deformation shown in Figure 6.1.

The shape of imperfection may be determined using the notional horizontal force in clause 2.5.8 or elastic critical mode in clause 6.4.4.

For regular multi-floor building frames, the shape may be simply taken as an inclined straight line.

These initial sway imperfections should be applied in all unfavourable horizontal directions, but need only be considered in one direction at a time.

For temporary works such as scaffolding, initial deformation should be taken as $\Delta = h / 100$. For demolition works, initial deformation equivalent to notional force specified in Code of Practice for Demolition of Buildings should be used.

The simulation of out-of-plumbness with notional horizontal force is indicated in Figure 6.3.

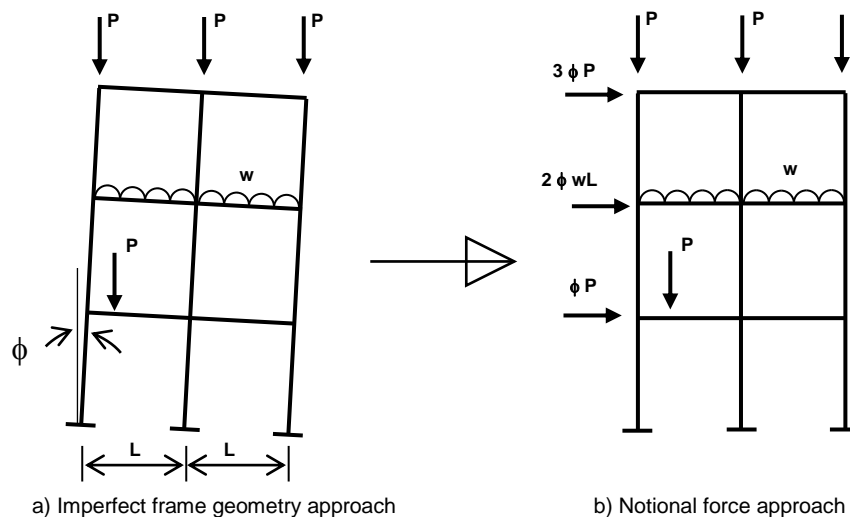

Figure 6.3 - Notional horizontal force for out-of-plumbness

6.4.3 Member imperfections

For a compression member, the equivalent initial bow imperfection specified in Table 6.1 may be used in second order analysis of the member.

Alternatively, the effects of imperfections can be considered in member design when using the effective length method and the moment amplification method in clause 8.9.2.

Table 6.1 - Values of member initial bow imperfection used in design

Buckling curves referenced in Table 8.7	$\frac{e_0}{L}$ to be used in Second-order P- Δ - δ elastic analysis
a ₀	1/550
a	1/500
b	1/400
c	1/300
d	1/200

In Table 6.1, e_0 is the amplitude of the initial bow imperfection. Variation of the initial bow imperfection v_0 along the member length is given by,

$$v_0 = e_0 \sin \frac{\pi x}{L} \quad (6.8)$$

L is the member length,

x is the distance along the member.

6.4.4 Elastic critical mode

For non-rectilinear frames whereby the method of notional horizontal force in clause 2.5.8 is inapplicable, the elastic buckling mode can be used to simulate the global imperfections. The amplitude of such global imperfection can be taken as building height / 200 for permanent structures or height / 100 for temporary structures. When the second order analysis is determined for use in structural analysis, the structure should be checked for stability and buckling strength using first global elastic buckling mode. Local elastic buckling mode of secondary member should not be used in place of the global elastic buckling mode.

6.5 SIMPLE DESIGN

Sway is prevented by connections and ties to a relatively rigid frame. Simple design can only be used when λ_{cr} of the frame system is not less than 10. The connections between members and columns are assumed to be pinned and the moment developed will not adversely affect the structural adequacy and robustness of the members or the structure. Sufficient connection flexibility should be designed and detailed. Sway stability should be provided by structures with adequate stiffness and strength to resist the lateral wind or notional horizontal force. Realistic assumption for eccentricity of reaction should be made in design. A minimum eccentricity of 100 mm between beam reaction and the face of column or the centre of stiff bearing length should be assumed.

6.6 FIRST-ORDER LINEAR ELASTIC ANALYSIS (FIRST-ORDER INDIRECT ANALYSIS)

6.6.1 General

P- Δ and P- δ effects should be checked in the member design by the moment amplification and the effective length methods. The first order linear elastic analysis method can only be used in rectilinear non-sway frames whereby the elastic critical load factor $\lambda_{cr} \geq 10$ and for rectilinear sway frames with $\lambda_{cr} \geq 5$. For the calculation of elastic critical load factor λ_{cr} , Equation 6.1 should only be used for rectilinear frames subjected to gravitational loads or gravitational loads plus horizontal loads (e.g. wind). For design of beam-columns, clause 8.9.2 should be referred to.

The indirect analysis referred in clauses 6.6 and 6.7 carries out an analysis without full consideration of geometric imperfections and a separate individual member design is necessary for a safe design.

6.6.2 Moment amplification for sway frames

The bending moment due to horizontal load is amplified by the following factor.

$$\frac{\lambda_{cr}}{\lambda_{cr} - 1} \quad (6.9)$$

where

λ_{cr} is the elastic critical load factor determined in clause 6.3.2.

Connections and connecting members should be designed using the amplified bending moment allowing for first-order and second-order P-Δ moments.

The P-Δ effect and moment amplification can be ignored for member and connection design when λ_{cr} is not less than 10.

6.6.3 Effective length for sway and non-sway frames

The effective length of a sub-frame in a continuous frame shown in Figure 6.4 can be determined using the distribution factors, k_1 and k_2 , at the column ends as,

$$k = \frac{\text{Total stiffness of the columns at the joint}}{\text{Total stiffness of all the members at the joint}} \quad (6.10)$$

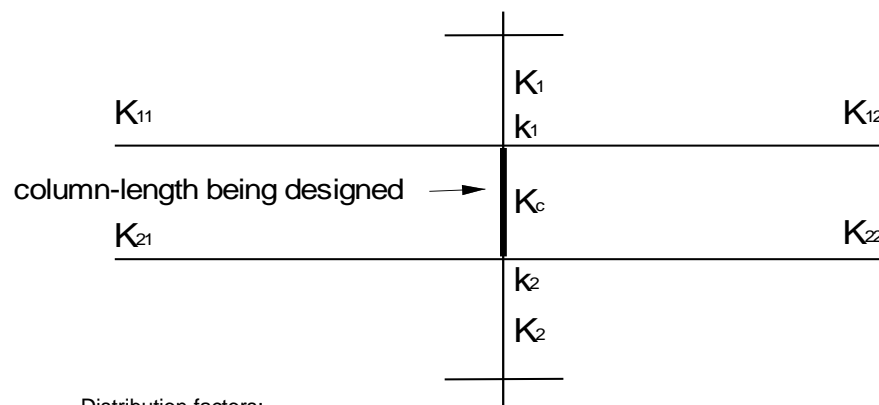

Distribution factors:

$$k_1 = \frac{K_c + K_1}{K_c + K_1 + K_{11} + K_{12}}$$

$$k_2 = \frac{K_c + K_2}{K_c + K_2 + K_{21} + K_{22}}$$

where

K_1 and K_2 are the values of K_c for the adjacent column lengths;

K_{11} , K_{12} , K_{21} and K_{22} are the values of K_b for the adjacent beams;

K_b , stiffness beam, should be taken as zero for the beam not to exist.

Figure 6.4 - Restraint coefficients for sub-frame

The effective length factor can be determined from Figures 6.5a and 6.5b using k_1 and k_2 determined from equation 6.10.

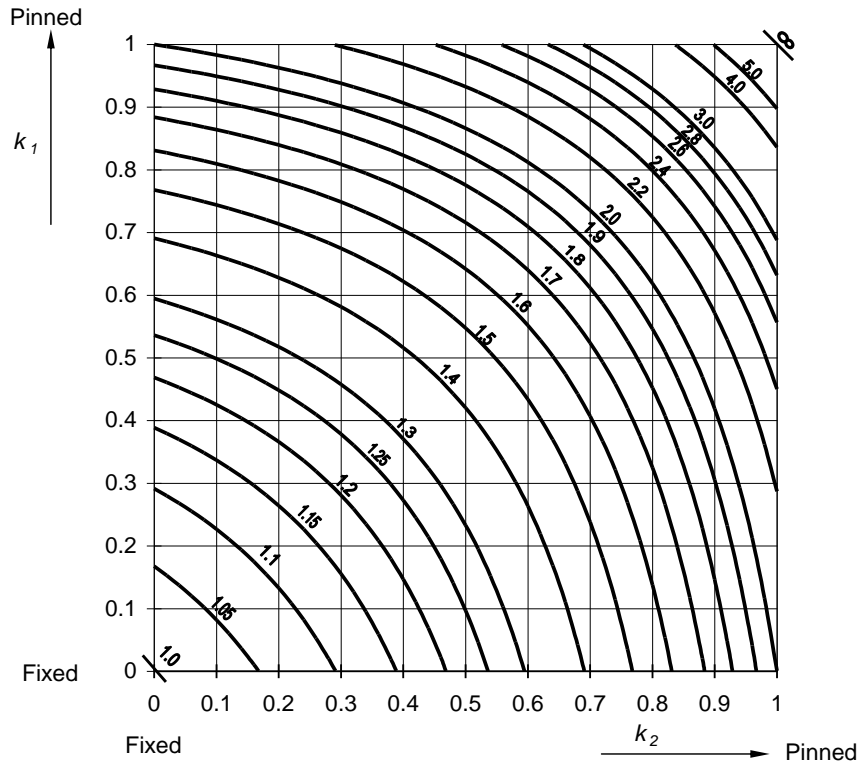

Figure 6.5a - Effective length factor (L_E/L) for sway frames

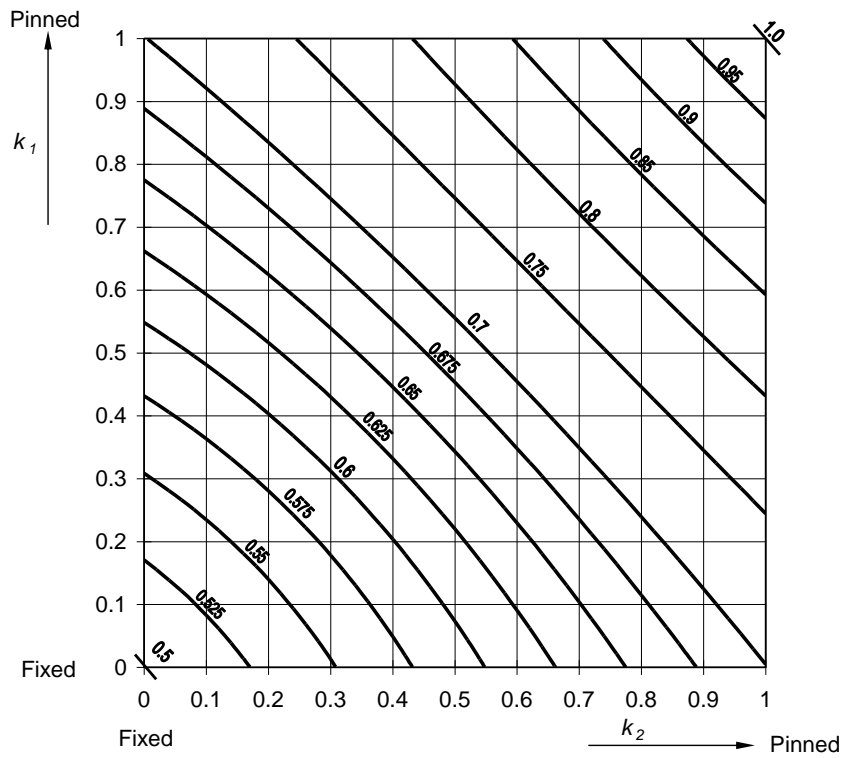

Figure 6.5b - Effective length factor (L_E/L) for non-sway frames

The stiffness of the beams should be taken from Table 6.2 with consideration of the following effects.

- When the moment at one end of the column exceeds 90% of its reduced moment capacity under the axial force, the value of k is taken as unity.
- When the axial force in restraining beams is significant, the stiffness reduction should be considered.
- When beams are linked to the joint by semi-rigid connections, the beam stiffness should be revised as,

$$k'_b = \frac{k_b k_{sp}}{k_b + k_{sp}} \quad (6.11)$$

where

k'_b and k_b are respectively the revised and the original beam stiffnesses and k_{sp} is the connection stiffness obtained from a laboratory test or the literature.

Table 6.2 - Stiffness of beam for effective length determination in continuous structures

Loading conditions of the beam	Non-sway mode	Sway mode
Beams supporting concrete or composite floor	$1.0 \frac{I}{L}$	$1.0 \frac{I}{L}$
Other beams under load along span	$0.75 \frac{I}{L}$	$1.0 \frac{I}{L}$
Other beams under end moments only	$0.5 \frac{I}{L}$	$1.5 \frac{I}{L}$

Note: I is the second-moment of area about the buckling axis and L is the member length.

6.6.4 Maximum slenderness ratio

The slenderness ratio should be limited to 200 for members in compression and 300 for members in tension except when a second-order analysis allowing for self weight and other member loads of the member is used or measures are taken against detrimental effects due to high slenderness.

6.7 SECOND-ORDER P-Δ-ONLY ELASTIC ANALYSIS (SECOND-ORDER INDIRECT ANALYSIS)

6.7.1 General

This analysis method considers the changes in nodal coordinate and sway such that the P-Δ effect is accounted for. The effect of member bowing (P-δ) is not considered here and should be allowed for separately. Member resistance check for P-δ effect to clause 8.7 is required and this P-Δ-only method of analysis and design is under the same limitations of use as the linear analysis.

6.7.2 Method of analysis

The analysis can be carried out by allowing change of nodal coordinates of a structure to assess the non-linear effects. The member effective length factor should be taken as 1 and the moments induced at member ends and along members should be amplified according to clause 8.9.2.

6.7.3 Applications and limitations

The second order P-Δ-only elastic analysis calculates the sway-induced P-Δ moment as an alternative to the amplification moment computed in clause 6.6.2. The connections and connecting members should be designed using this refined bending moment, which allows for first-order bending moment and the second-order P-Δ moments. The column buckling resistance should be determined to clause 8.9.2.

6.8 SECOND-ORDER P-Δ-δ ELASTIC ANALYSIS (SECOND-ORDER DIRECT ANALYSIS)

6.8.1 General

Both the P-Δ and P-δ effects are accounted for in the computation of bending moment in this method. Checking the buckling resistance of a structure to clause 6.8.3 is sufficient and member check to clause 8.9.2 is not needed. The direct analysis here allows an accurate determination of structural response under loads via the inclusion of the effects of geometric imperfections and stiffness changes directly in the structural analysis and equations 6.12 to 6.14 for section capacity check in the structural analysis are sufficient for structural resistance design.

6.8.2 Method of analysis

A second-order P-Δ-δ elastic analysis considers the followings.

- (1) Equilibrium in the deformed position of the structure (i.e. P-Δ effect);
- (2) Member bowing deflection and stiffness change (i.e. P-δ effect); and
- (3) Frame and member imperfections in clause 6.4.

6.8.3 Applications and limitations

The method is limited to the capacity at the load level where the first plastic hinge for Class 1 and Class 2 is formed or the maximum stress at extreme fibre for Class 3 and Class 4 reaches the design strength. Except for Class 4 slender sections, the sectional capacity should be checked using the following equation allowing for the P-Δ and P-δ effects.

$$\frac{F_c}{A_g p_y} + \frac{M_x}{M_{cx}} + \frac{M_y}{M_{cy}} = \frac{F_c}{A_g p_y} + \frac{\bar{M}_x + F_c(\Delta_x + \delta_x)}{M_{cx}} + \frac{\bar{M}_y + F_c(\Delta_y + \delta_y)}{M_{cy}} \leq 1 \quad (6.12)$$

in which

δ_x, δ_y are the member deflections due to member initial bow and loads on the member and about x- and y-axes.

As an alternative to Equation 6.12, section capacity could be checked by the following reduced moment capacities equation.

$$\left(\frac{M_x}{M_{rx}}\right)^{z_1} + \left(\frac{M_y}{M_{ry}}\right)^{z_2} = \left(\frac{\bar{M}_x + F_c(\Delta_x + \delta_x)}{M_{rx}}\right)^{z_1} + \left(\frac{\bar{M}_y + F_c(\Delta_y + \delta_y)}{M_{ry}}\right)^{z_2} \leq 1 \quad (6.13)$$

in which M_{rx} and M_{ry} are reduced moment capacities about x- and y-axes by assuming the area nearest to centroid of the cross section would take the axial load F_c with the remaining area used in computing moment resistances M_{rx} and M_{ry} .

z_1 and z_2 are constants taken as follows.

For I- and H- sections with equal flanges,

$$z_1 = 2.0 \quad z_2 = 1.0$$

For solid and hollow circular sections,

$$z_1 = z_2 = 2.0$$

For solid and hollow rectangular sections,

$$z_1 = z_2 = 1.6$$

For all other sections,

$$z_1 = z_2 = 1.0$$

For Class 4 slender cross-sections, the effective area A_{eff} should be used in place of the gross sectional area in Equations 6.12 and 6.13.

Member lateral-torsional and torsional buckling checks are carried out separately or alternatively by replacing M_{cx} in the above equation by the buckling resistance moment M_b in Equations 8.20 to 8.22. If moment equivalent factor m_{LT} is less than 1, both Equation 6.12 or 6.13 and Equation 6.14 are required for member resistance check.

$$\frac{F_c}{A_g p_y} + \frac{M_x}{M_{cx}} + \frac{M_y}{M_{cy}} = \frac{F_c}{A_g p_y} + \frac{m_{LT}[\bar{M}_x + F_c(\Delta_x + \delta_x)]}{M_b} + \frac{m_y[\bar{M}_y + F_c(\Delta_y + \delta_y)]}{M_{cy}} \leq 1 \quad (6.14)$$

The equivalent uniform moment factor m_{LT} for beams and the moment equivalent factor m_y for flexural buckling can be referred to Tables 8.4 a & b and Table 8.9.

For members in bending and sensitive to buckling, imperfection on both axes should be considered if effective length has reduction in capacity about buckling in both axes.

6.9 ADVANCED ANALYSIS

6.9.1 General

Advanced analysis may be used when the design load induces plasticity in a structure. Instability, P- Δ and P- δ effects, and frame and member initial imperfections should be accounted for so that the non-linear structural behaviour can be captured in the analysis.

In advanced analysis, the strength, the stiffness and the ductility limits must be satisfied. The member cross-sections shall be Class 1 plastic section for members containing plastic hinges or at least Class 2 compact section for members without being designed for formation of plastic hinges. Frames made of other sections may also be designed by the advanced analysis when the local buckling effects are properly accounted for.

When advanced plastic analysis is used, the frame should be effectively restrained against significant displacement out of the plane of the frame or out-of-plane buckling is checked for individual members. Unless the effect of out-of-plane buckling has been considered, lateral restraint shall be provided at all plastic hinge locations. The restraint should be provided within a distance along the member from the theoretical plastic hinge location not exceeding half the depth of the member. The effects due to residual stress, erection procedure, interaction with foundation and temperature change should be taken into account in the analysis.

6.9.2 Method of analysis

A full second-order plastic hinge or plastic zone analysis can be used in an Advanced Analysis. The method should consider the followings.

- (1) Equilibrium in the deformed position of the structure;
- (2) Member bowing deflection and stiffness change;
- (3) Frame and member imperfections in clause 6.4;
- (4) Material yielding by plastic hinge or plastic zone models; and
- (5) Ductility adequacy in plastic hinges (i.e. The rotation capacity should be larger than the rotation at maximum design moment or moment in the design range).

6.9.3 Applications and limitations

The method only directly locates the maximum limit load of a structure allowing for the formation of plastic hinges and under different load cases.

6.10 BRACING MEMBERS

The shape of imperfection should be determined using the elastic critical mode with the amplitude of initial bowing imperfection as:

$$e_o = k_r L / 500 \quad (6.15)$$

where L is the span of the bracing system and

$$k_r = \sqrt{0.2 + \frac{1}{n_r}} \text{ but } k_r \leq 1.0 \quad (6.16)$$

where n_r is the number of members being restrained by the bracing member.

6.11 CONNECTION CLASSIFICATION IN ANALYSIS

Connections can be classified as pinned, rigid or semi-rigid, depending on their strength, stiffness and rotational capacity. The detailing and design of connections must be consistent with the assumptions used in the calculation.

The strength and stiffness capacity of connections should be consistent with the assumptions made in the analysis and design. For advanced analysis, rotational capacity should also satisfy the rotational requirement in analysis.

6.11.1 Pinned connections

A pinned connection shall be designed and detailed to avoid development of significant moment affecting adversely the members of the structure. It should also be capable of transmitting forces calculated in the design and allowing for sufficient rotations.

6.11.2 Rigid connections

A rigid connection shall be designed and detailed such that its deformation will not adversely affect the force and moment distribution and stiffness of members in the frame. It should be able to transmit forces and moments calculated in design.

6.11.3 Semi-rigid connections

Semi-rigid connections include those connections which cannot satisfy the pinned or rigid connections requirements in clauses 6.11.1 and 6.11.2. The moment and deformation of a semi-rigid connection should not adversely affect members in a frame and the connection should be modeled in an analysis indicated in Figure 6.6 with connection stiffness obtained from literatures or by tests. It should be designed and detailed to have the capacity to transmit calculated forces and moment and to deform suitably to accept the rotation.

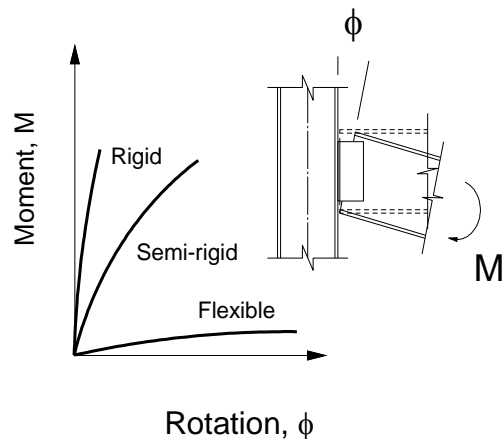

Figure 6.6 - Connection behaviour

7 SECTION CLASSIFICATION

7.1 GENERAL

Cross-sections subject to compression due to axial load or bending moment should be classified into Class 1 plastic, Class 2 compact, Class 3 semi-compact or Class 4 slender, depending on their width to thickness ratios of section elements and hence, their susceptibility against local buckling. Cross-sections should be classified to determine whether local buckling influences their section capacity, without calculating their local buckling resistance. This section covers steel grades with design strength not greater than 690 N/mm² and its extension to higher steel grades should be justified.

The classification of each element of a cross-section subject to compression should be based on its width-to-thickness ratio. The dimensions of these compression elements should be taken as shown in Figure 7.1. The elements of a cross-section are generally of constant thickness. For elements taper in thickness, the thickness specified in the relevant standard should be used.

A distinction should be made between the following two types of element,

- (a) Outstand elements are attached to adjacent elements at one edge only while the other edge being free.
- (b) Internal elements are attached to other elements on both longitudinal edges and including:
 - *Webs* comprising internal elements perpendicular to the axis of bending
 - *Flanges* comprising internal elements parallel to the axis of bending

All compression elements should be classified in accordance with clause 7.2. Generally, the complete cross-section should be classified according to the highest (least favourable) class of its compression elements. Alternatively, a cross-section may be classified with its compression flange and its web in different classes.

Circular hollow sections should be classified separately for axial compression and for bending.

For the design of compression elements with longitudinal stiffeners, acceptable reference should be made.

Formulae in this clause shall be applicable to high strength steel, provided that it meets the requirements in strength, resistance to brittle fracture, ductility and weldability required in clause 3.1.3.

7.2 CLASSIFICATION

Class 1 plastic:

Cross-sections with plastic hinge rotation capacity. A plastic hinge can be developed with sufficient rotation capacity to allow redistribution of moments within the structure. Elements subject to compression that meet the limits for Class 1 given in Table 7.1 or Table 7.2 should be classified as Class 1 plastic.

Class 2 compact:

Cross-sections with plastic moment capacity. The plastic moment capacity can be developed, but local buckling may prevent the development of plastic hinge with sufficient rotation capacity at the section. Elements subject to compression that meet the limits for Class 2 given in Table 7.1 or Table 7.2 should be classified as Class 2 compact.

Class 3 semi-compact:

Cross-sections in which the stress at the extreme compression fibre can reach the design strength, but the plastic moment capacity cannot be developed. Elements subject to compression that meet the limits for Class 3 given in Table 7.1 or Table 7.2 should be classified as Class 3 semi-compact.

Class 4 slender:

Cross-sections in which it is necessary to make explicit allowance for the effects of local buckling which prevents the development of the elastic capacity in compression and/or bending. Elements subject to compression that do not meet the limits for Class 3 semi-compact given in Table 7.1 or Table 7.2 should be classified as Class 4 slender. In these cross-sections, the stress at the extreme compression fibre cannot reach the design strength.

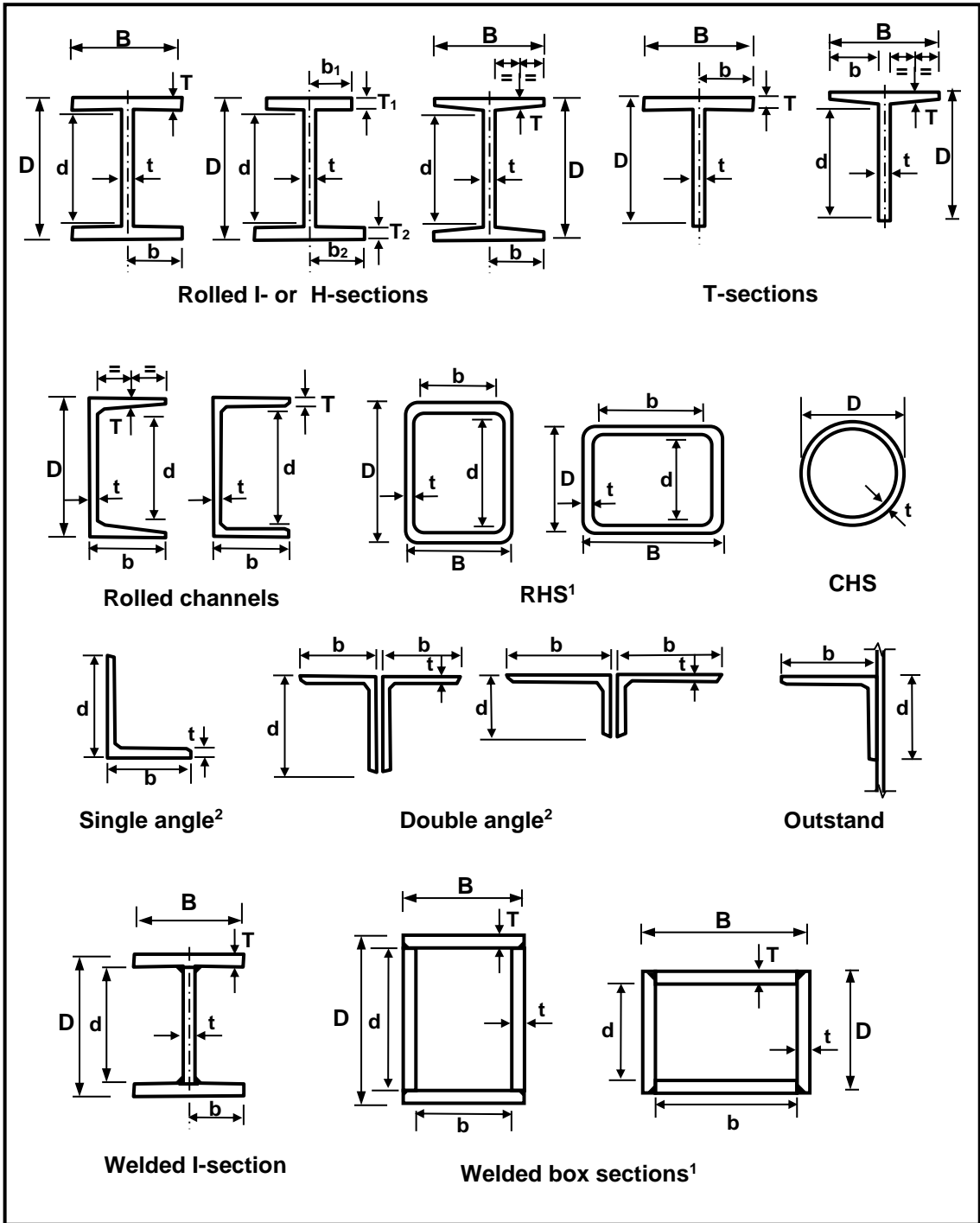

¹ For a RHS or box section, B and b are flange dimensions and D and d are web dimensions. The distinction between webs and flanges depends upon whether the member is bent about its major axis or minor axis, see clause 7.1.
For a RHS, dimensions b and d are defined in footnote a to c Table 7.2.

² For an angle, b is the dimension of the outstand leg and d is the dimension of the connected leg.
Special care should be taken in sections fabricated by thick plates to avoid lamellar tearing.

Figure 7.1 - Dimensions of compression elements

Table 7.1 - Limiting width-to-thickness ratios for sections other than CHS and RHS

Compression element				Ratio ^a	Limiting value ^b		
					Class 1 plastic	Class 2 compact	Class 3 semi-compact
Flange	Outstand element	Compression due to bending	Rolled section	b/T	9ε	10ε	15ε
			Welded section		8ε	9ε	13ε
	Axial compression			b/T	Not applicable		13ε
	Internal element	Compression due to bending		b/T	28ε	32ε	40ε
		Axial compression		b/T	Not applicable		
Web of an I-, H- or Box section ^d	Neutral axis at mid-depth			d/t	80ε	100ε	120ε
	Generally ^c	r_1 is negative		d/t	$\frac{80\varepsilon}{1+r_1}$ but $\geq 40\varepsilon$	$\frac{100\varepsilon}{1+r_1}$	$\frac{120\varepsilon}{1+2r_2}$ but $\geq 40\varepsilon$
		r_1 is positive		d/t		$\frac{100\varepsilon}{1+1.5r_1}$ but $\geq 40\varepsilon$	
	Axial compression ^c			d/t	Not applicable		
Web of a channel				d/t	40ε	40ε	40ε
Angle, compression due to bending (Both criteria should be satisfied)				b/t d/t	9ε 9ε	10ε 10ε	15ε 15ε
Single angle, or double angles with the components separated, axial compression (All three criteria should be satisfied)				b/t d/t $(b+d)/t$	Not applicable		15ε 15ε 24ε
Outstand leg of an angle in contact back-to-back in a double angle member				b/t	9ε	10ε	15ε
Outstand leg of an angle with its back in continuous contact with another component							
Stem of a T-section, rolled or cut from a rolled I- or H-section				D/t	8ε	9ε	18ε
^a Dimensions b , D , d , T and t are defined in Figure 7.1. For a box section b and T are flange dimensions and d and t are web dimensions, where the distinction between webs and flanges depends upon whether the box section is bent about its major axis or its minor axis, see clause 7.1.							
^b The parameter $\varepsilon = \sqrt{\frac{275}{p_y}}$ where p_y is in N/mm ²							
^c The stress ratios r_1 and r_2 are defined in clause 7.3.							
^d For the web of a hybrid section ε should be based on the design strength p_{yf} of the flanges.							

Table 7.2 - Limiting width-to-thickness ratios for CHS and RHS

Compression element		Ratio ^a	Limiting value ^b			
			Class 1 plastic	Class 2 compact	Class 3 semi-compact	
CHS	Compression due to bending		D/t	$40\varepsilon^2$	$50\varepsilon^2$	$140\varepsilon^2$
	Axial compression		D/t	Not applicable		$80\varepsilon^2$
HF RHS	Flange	Compression due to bending	b/t	28ε but $\leq 80\varepsilon - d/t$	32ε but $\leq 62\varepsilon - 0.5d/t$	40ε
		Axial compression	b/t	Not applicable		
	Web	Neutral axis at mid-depth	d/t	64ε	80ε	120ε
		Generally ^c	d/t	$\frac{64\varepsilon}{1+0.6r_1}$ but $\geq 40\varepsilon$	$\frac{80\varepsilon}{1+r_1}$ but $\geq 40\varepsilon$	$\frac{120\varepsilon}{1+2r_2}$
		Axial compression ^c	d/t	Not applicable		but $\geq 40\varepsilon$
CF RHS	Flange	Compression due to bending	b/t	26ε but $\leq 72\varepsilon - d/t$	28ε but $\leq 54\varepsilon - 0.5d/t$	35ε
		Axial compression	b/t	Not applicable		
	Web	Neutral axis at mid-depth	d/t	56ε	70ε	105ε
		Generally ^c	d/t	$\frac{56\varepsilon}{1+0.6r_1}$ but $\geq 35\varepsilon$	$\frac{70\varepsilon}{1+r_1}$ but $\geq 35\varepsilon$	$\frac{105\varepsilon}{1+2r_2}$
		Axial compression ^c	d/t	Not applicable		but $\geq 35\varepsilon$
<p>Abbreviations</p> <p>CF Cold formed;</p> <p>CHS Circular hollow section — including welded tube;</p> <p>HF Hot finished;</p> <p>RHS Rectangular hollow section — including square hollow section.</p>						
<p>^a For an RHS, the dimensions b and d should be taken as follows:</p> <p>— for HF RHS: $b = B - 3t$, $d = D - 3t$</p> <p>— for CF RHS: $b = B - 5t$, $d = D - 5t$</p> <p>and B, D and t are defined in Figure 7.1. For an RHS subject to bending, B and b are always flange dimensions, and D and d are always web dimensions, but the definition of which sides of the RHS are webs and which are flanges changes according to the axis of bending, see clause 7.1.</p> <p>^b The parameter $\varepsilon = \sqrt{\frac{275}{p_y}}$ where p_y is in N/mm²</p> <p>^c The stress ratios r_1 and r_2 are defined in clause 7.3.</p>						

7.3 STRESS RATIOS FOR CLASSIFICATION

The stress ratios r_1 and r_2 used in Tables 7.1 and 7.2 should be calculated from the following:

(a) I- or H-sections with equal flanges:

$$r_1 = \frac{F_c}{dtp_{yw}} \quad \text{but } -1 < r_1 \leq 1 \quad (7.1)$$

$$r_2 = \frac{F_c}{A_g p_{yw}} \quad (7.2)$$

(b) I- or H-sections with unequal flanges:

$$r_1 = \frac{F_c}{dtp_{yw}} + \frac{(B_t T_t - B_c T_c) p_{yf}}{dtp_{yw}} \quad \text{but } -1 < r_1 \leq 1 \quad (7.3)$$

$$r_2 = \frac{f_1 + f_2}{2p_{yw}} \quad (7.4)$$

(c) RHS or welded box sections with equal flanges:

$$r_1 = \frac{F_c}{2dtp_{yw}} \quad \text{but } -1 < r_1 \leq 1 \quad (7.5)$$

$$r_2 = \frac{F_c}{A_g p_{yw}} \quad (7.6)$$

where

- A_g = gross cross-sectional area;
- B_c = width of the compression flange;
- B_t = width of the tension flange;
- d = web depth;
- F_c = axial compression (negative for tension);
- f_1 = maximum compressive stress in the web, see Figure 7.2;
- f_2 = minimum compressive stress in the web (negative for tension), see Figure 7.2;
- p_{yf} = design strength of the flange;
- p_{yw} = design strength of the web (but $p_{yw} \leq p_{yf}$);
- T_c = thickness of the compression flange;
- T_t = thickness of the tension flange;
- t = web thickness.

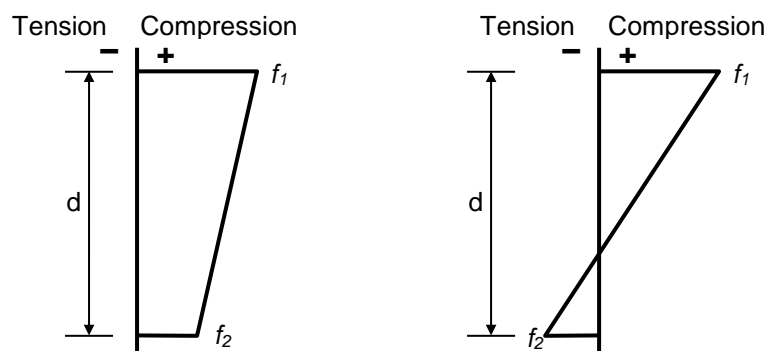

Figure 7.2 - Stress ratio for a semi-compact web

7.4 FLANGES OF COMPOUND I- OR H-SECTIONS

The classification of the compression flange of a compound section, fabricated by welding a flange plate to a rolled I- or H-section should take into account of the width-to-thickness ratios shown in Figure 7.3 as follows:

- The ratio of the outstand b of the compound flange, as shown in Figure 7.3(a), to the thickness T of the original flange should be classified under "outstand element of compression flange-rolled section", see Table 7.1.
- The ratio of the internal width b_p of the plate between the lines of welds or bolts connecting it to the original flange, as shown in Figure 7.3(b), to the thickness t_p of the plate should be classified under "internal element of compression flange", see Table 7.1.
- The ratio of the outstand b_o of the plate beyond the lines of welds or bolts connecting it to the original flange, as shown in Figure 7.3(c), to the thickness t_p of the plate should be classified under "outstand element of compression flange-welded section", see Table 7.1.

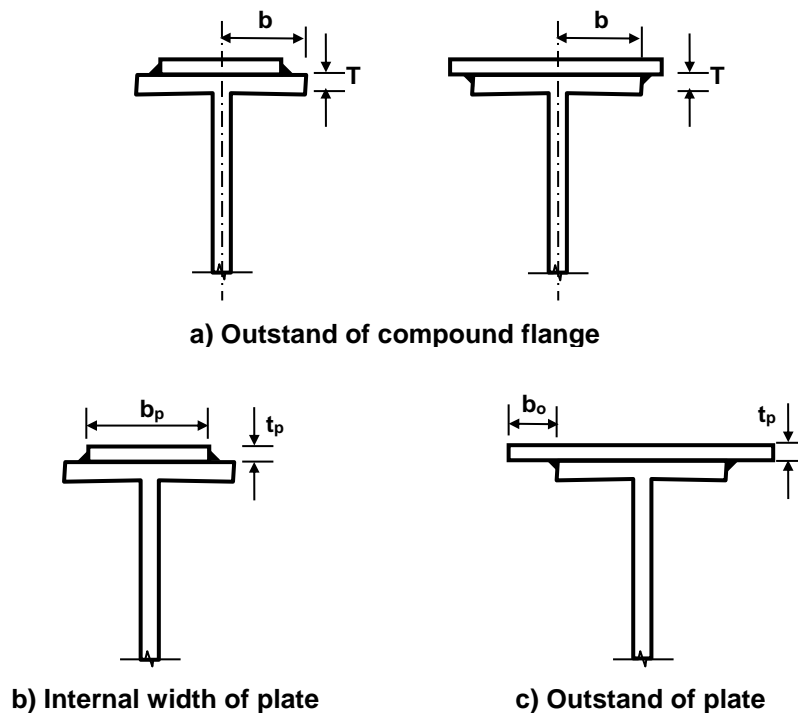

Figure 7.3 - Dimensions of compound flanges

The equivalent uniform moment factor m_{LT} for beams and the moment equivalent factor m for flexural buckling can be referred to Tables 8.4 a & b and Table 8.9.

7.5 EFFECTIVE PLASTIC MODULUS

7.5.1 General

Class 3 semi-compact sections subject to bending should be designed using either the section modulus Z or the effective plastic modulus S_{eff} .

For I- or H-sections with equal flanges, RHS and CHS, the effective plastic modulus should be determined from clause 7.5.2, 7.5.3 or 7.5.4 respectively.

For I- or H-sections with unequal flanges subject to bending in the plane of the web, acceptable reference should be made.

For other cross-sections S_{eff} should be taken as equal to the section modulus Z .

7.5.2 I- or H-sections with equal flanges

For Class 3 semi-compact I- or H-sections with equal flanges, the effective plastic modulus $S_{x,eff}$ and $S_{y,eff}$ for major and minor axes bending may be obtained from:

$$S_{x,eff} = Z_x + (S_x - Z_x) \frac{\left[\left(\frac{\beta_{3w}}{d/t} \right)^2 - 1 \right]}{\left[\frac{\beta_{3w}}{\beta_{2w}} \right]^2 - 1} \quad \text{and} \quad S_{y,eff} = Z_y + (S_y - Z_y) \frac{\left[\frac{\beta_{3f}}{b/T} - 1 \right]}{\left[\frac{\beta_{3f}}{\beta_{2f}} - 1 \right]} \quad (7.7 \text{ \& } 7.8)$$

$$\text{but} \quad S_{x,eff} \leq Z_x + (S_x - Z_x) \frac{\left[\frac{\beta_{3f}}{b/T} - 1 \right]}{\left[\frac{\beta_{3f}}{\beta_{2f}} - 1 \right]} \quad (7.9)$$

where

b , d , T and t are defined in Figure 7.1

S_x = plastic modulus about the major axis

S_y = plastic modulus about the minor axis

Z_x = section modulus or elastic modulus about the major axis

Z_y = section modulus or elastic modulus about the minor axis

β_{2f} = limiting value of b/T from Table 7.1 for Class 2 compact flange

β_{2w} = limiting value of d/t from Table 7.1 for Class 2 compact web

β_{3f} = limiting value of b/T from Table 7.1 for Class 3 semi-compact flange

β_{3w} = limiting value of d/t from Table 7.1 for Class 3 semi-compact web

7.5.3 Rectangular hollow sections

For Class 3 semi-compact rectangular hollow sections (RHS), the effective plastic moduli $S_{x,eff}$ and $S_{y,eff}$ for major and minor axis bending may both be obtained by considering bending about the respective axis, using the following:

$$S_{eff} = Z + (S - Z) \frac{\left[\frac{\beta_{3w}}{d/t} - 1 \right]}{\left[\frac{\beta_{3w}}{\beta_{2w}} - 1 \right]} \quad (7.10)$$

$$\text{but} \quad S_{eff} \leq Z + (S - Z) \frac{\left[\frac{\beta_{3f}}{b/t} - 1 \right]}{\left[\frac{\beta_{3f}}{\beta_{2f}} - 1 \right]} \quad (7.11)$$

where

b , d and t of RHS are defined in Table 7.2

β_{2f} = limiting value of b/t from Table 7.2 for Class 2 compact flange

β_{2w} = limiting value of d/t from Table 7.2 for Class 2 compact web

β_{3f} = limiting value of b/t from Table 7.2 for Class 3 semi-compact flange

β_{3w} = limiting value of d/t from Table 7.2 for Class 3 semi-compact web

For a RHS subject to bending, B and b are always flange dimensions and D and d are always web dimensions, but the definition of which sides of the RHS are webs and which are flanges changes according to the axis of bending, see clause 7.1.

7.5.4 Circular hollow sections

For Class 3 semi-compact circular hollow sections (CHS) of overall diameter D and thickness t , the effective plastic modulus S_{eff} may be obtained from:

$$S_{eff} = Z + 1.45 \left[\left(\sqrt{\frac{140}{D/t}} \right) \varepsilon - 1 \right] (S - Z) \quad (7.12)$$

7.6 EFFECTIVE WIDTH METHOD FOR SLENDER CROSS-SECTIONS

Local buckling in Class 4 slender cross-sections may be allowed for in design by adopting effective section properties. Due allowance should be made for the possible effects of any shift of the centroid of the effective cross-section. Effective section properties can be obtained from Chapter 11 or any acceptable reference.

7.7 EFFECTIVE STRESS METHOD FOR SLENDER CROSS-SECTIONS

Effective stress method is an alternative method to the effective width method detailed in clause 7.6. Effective stress method reduces the design strength p_{yr} that may be calculated at which the cross-section would be Class 3 semi-compact. The reduced design strength p_{yr} should then be used in place of p_y in the checks on section capacity and member buckling resistance. The value of this reduced design strength p_{yr} may be obtained from:

$$p_{yr} = \left(\frac{\beta_3}{\beta} \right)^2 p_y \quad (7.13)$$

in which β is the value of b/T , b/t , D/t or d/t that exceeds the limiting value β_3 given in Table 7.1 or Table 7.2 for a Class 3 semi-compact section.

It should be noted that unless the Class 3 semi-compact limit is exceeded by only a small margin, the use of this alternative method can be rather conservative.

7.8 SHIFT OF THE CENTROID OF THE EFFECTIVE CROSS-SECTION

Local buckling is a major consideration in the design of Class 4 slender cross-sections. The main effect of local buckling is to cause a redistribution of the longitudinal stress in which the greatest portion of the load is carried near the plate junctions, as shown for a channel section in Figures 7.4(a) and 7.4(b). The redistribution produces increased stresses near the plate junctions and high bending stresses as a result of plate flexure, leading to ultimate loads below the squash load of the section.

For singly symmetric cross-sections, the redistribution of longitudinal stress caused by local buckling also produces a shift of the centroid of the effective cross-section, as shown in Figures 7.4(a) and 7.4(b). The shift of effective centroid caused by local buckling does not induce overall bending in fixed-ended singly symmetric columns as it does in pin-ended singly symmetric columns. For fixed-ended singly symmetric columns, the applied load always passes through the effective centroid of the cross-section. Hence, the effect of the shift in the line of action of the internal force due to local buckling shall be ignored in the checks on section capacity and member buckling resistance. For pin-ended singly symmetric columns, the shift of the effective centroid introduces an eccentricity and caused applied moment to the member. This shift must be taken into account in the checks on section capacity and member buckling resistance, in which the applied moment is calculated as a product of the axial force and its eccentricity.

The design eccentricity can be determined using the effective widths of each component plate and thus an effective cross-section with distinct centroid, referred to as the “effective centroid”, as shown in Figure 7.4(c). The design eccentricity is determined as the distance from the effective centroid to the applied force.

For doubly symmetric cross-sections subjected to compression, there is no shift of the centroid of the effective cross-section, as shown in Figure 7.5; whereas for doubly symmetric cross-sections subjected to bending, a shift of the centroid of the effective cross-section needs to be considered, as shown in Figure 7.6.

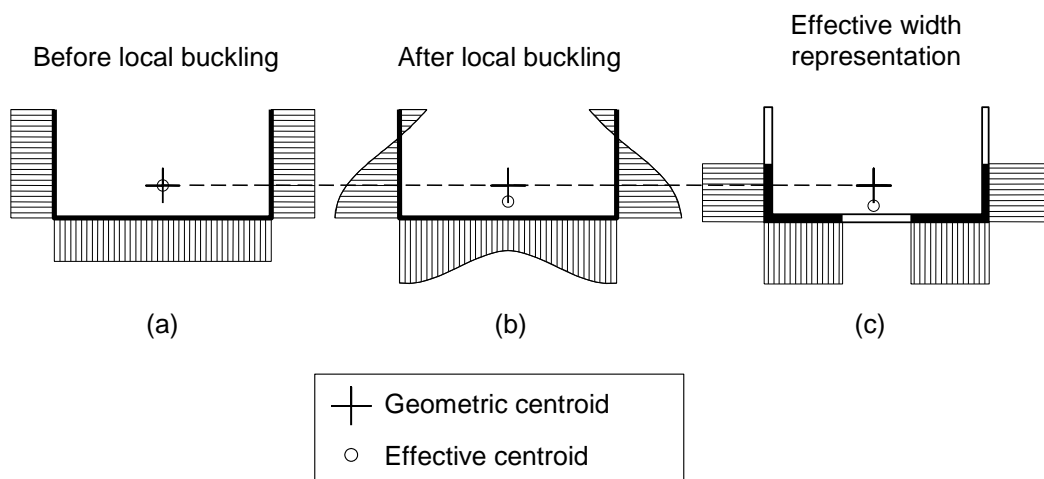

Figure 7.4 - Stress redistribution of singly symmetric slender cross-section subjected to compression

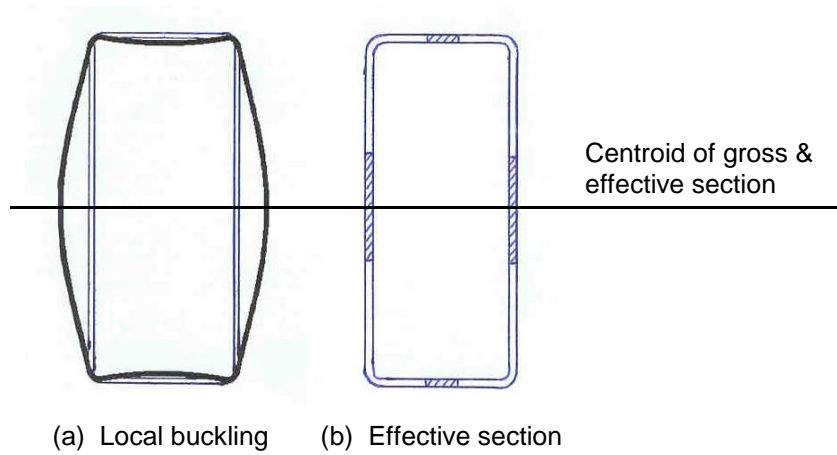

Figure 7.5 - Doubly symmetric slender cross-section subjected to compression

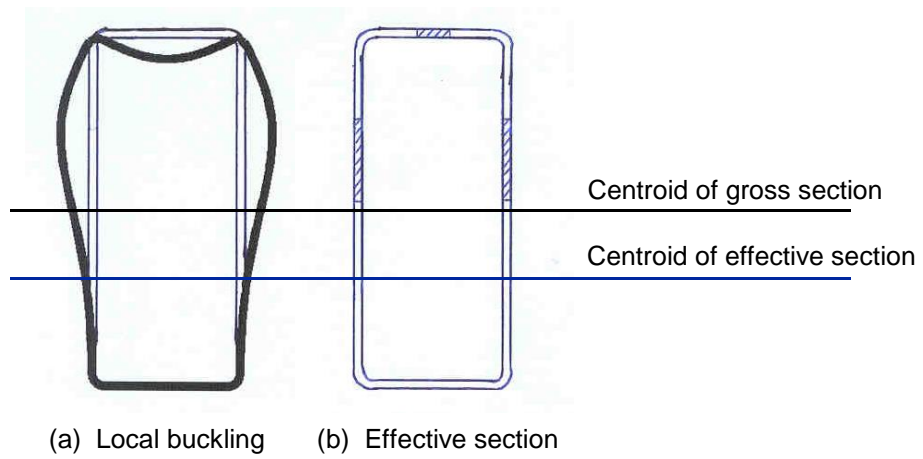

Figure 7.6 - Doubly symmetric slender cross-section subjected to bending

8 DESIGN OF STRUCTURAL MEMBERS

8.1 GENERAL

This section gives recommendations for the design of simple members and of members that form part of a frame. Refer to section 7 of the Code for classification of sections and section 3 for material design strength. Member resistance and section capacity should be not less than design load effects. Design requirements should be satisfied for local plate buckling; web buckling and crushing; and deflection and vibration.

The same design principles should be applied when steel materials from countries other than those given in Annex A1.1 are used. The steel material and its manufacturer shall comply with the requirements for Class 2 steel given in clause 3.1.1 of the Code. Material properties provided by the manufacturers may be used together with appropriate values of imperfection constant and material factors given in Appendices 8.1 to 8.4.

When Class 3 uncertified steel is used, the buckling curves for the steel material should be obtained from a reliable source and the material buckling strength so determined should be limited to the material strength given in clause 3.1.4.

The buckling design of asymmetric and unequal-flanged sections is not covered in this section, except for angle and tee sections.

Engineers are recommended to check the structure for torsion and warping from the first principle of stress analysis.

8.2 RESTRAINED BEAMS

Restrained beams refer to beams provided with full lateral restraint to their top flanges and with nominal torsional restraint at their ends. In such a case, lateral-torsional buckling should not occur before plastic moment capacity.

Full lateral restraint can be assumed when the compression flange of a beam is connected positively to a floor or to similar structural elements capable of providing a lateral restraining force. This lateral restraining force shall be 2.5% of the maximum force in the compression flange of the member, or more simply 2.5% of the squash load of the compression flange. This lateral force should be provided uniformly along the flange with the self weight and imposed loading from the floor forming the dominant mode of loading on the member.

8.2.1 Shear capacity

For loads parallel to the webs, the shear capacity V_c given below should not be less than the design shear force V .

$$V_c = \frac{p_y A_v}{\sqrt{3}} \geq V \quad (8.1)$$

in which

A_v is the shear area given by,

Rolled I, H and channels sections	tD
Welded I-sections	td
Rolled and welded rectangular hollow section	$2td$
Rolled and welded T-sections	$t(D - T)$
Circular hollow sections	$0.6A$
Solid rectangular sections	$0.9A$
Others	$0.9A_o$

where

- A is the cross-sectional area;
 A_0 is the area of the rectilinear element in the cross-section with largest dimension parallel to the design shear force direction;
 B is the overall breadth;
 D is the overall depth;
 d is the depth of the web;
 T is the flange thickness;
 t is the web thickness.

Shear buckling resistance should be checked in accordance with clause 8.4.6.

8.2.2 Moment capacity

The moment capacity of a fully restrained beam is given below and should not be less than the design bending moment.

8.2.2.1 Low shear condition

The following equations should be used when the design shear force V is not larger than 0.6 of the shear capacity V_c .

For Class 1 plastic and Class 2 compact sections:

$$M_c = p_y S \leq 1.2 p_y Z \quad (8.2)$$

For Class 3 semi-compact sections:

$$M_c = p_y Z \quad (8.3)$$

$$\text{or } M_c = p_y S_{eff} \quad (8.4)$$

For Class 4 slender sections:

$$M_c = p_y Z_{eff} \quad (8.5)$$

$$\text{or } M_c = p_{yr} Z \quad (8.6)$$

where

- S is the plastic modulus;
 Z is the elastic modulus;
 S_{eff} is the effective plastic modulus;
 Z_{eff} is the effective elastic modulus;
 p_{yr} is the design strength reduced for slender sections.

When high strength steel is used, the use of a Class 4 slender section is not permitted. When ultra high strength steel is used, the use of a plastic modulus is not permitted.

8.2.2.2 High shear condition

The following equations should be used when the design shear force V is larger than 0.6 of the shear capacity V_c .

For Class 1 plastic and Class 2 compact sections:

$$M_c = p_y (S - \rho S_v) \leq 1.2 p_y (Z - \rho S_v / 1.5) \quad (8.7)$$

For Class 3 semi-compact sections:

$$M_c = p_y (Z - \rho S_v / 1.5) \quad (8.8)$$

$$\text{or } M_c = p_y (S_{eff} - \rho S_v / 1.5) \quad (8.9)$$

For Class 4 slender sections:

$$M_c = p_y (Z_{eff} - \rho S_v / 1.5) \quad (8.10)$$

where

- S_v is the plastic modulus of shear area A_v in clause 8.2.1.

ρ is given by $\left(\frac{2V}{V_c} - 1\right)^2$;

V_c is the shear capacity;

V is the design shear.

When the web slenderness d/t is larger than 70ε for hot-rolled sections, or 62ε for welded sections, the moment capacity should allow for shear buckling as given in clause 8.4.6.

8.2.2.3 Notched ends

When parts of the flanges are curtailed for notched end connections of I, H or channel sections, the moment capacity should be taken as follows:

8.2.2.3.1 Low shear condition at notched ends

When the design shear force V is not larger than 0.75 of the shear capacity V_c of the notched area,

$$M_c = p_y Z_r \quad (8.11)$$

8.2.2.3.2 High shear condition at notched ends

When the design shear force V is larger than 0.75 of the shear capacity V_c of the notch area,

$$M_c = 1.5 p_y Z_r \sqrt{1 - \left(\frac{V}{V_c}\right)^2} \quad (8.12)$$

where,

Z_r is the elastic modulus of the section after deduction for the notched material.

8.2.3 Beams with web openings

Where openings are present in beams a reduction in their strength and stiffness should be considered in design. When the strength of such beams is inadequate, reinforcement should be provided. The minimum net section properties should be used for the lateral-torsional buckling check of beams with openings, refer to clause 8.3.

8.2.3.1 Isolated circular openings

8.2.3.1.1 Unreinforced openings

Net section properties are not required in design when the following conditions are met:

- The member is a plastic Class 1 or compact Class 2 section.
- The cross-section is symmetrical about the plane of bending.
- The opening is located within the middle third of the depth of the section and the middle half of the span of the member.
- The spacing of openings along the member longitudinal axis is not less than 2.5 times the opening diameter or the larger of the opening diameter when they are of different size.
- The distance between the centre of each opening to the nearest point load is not less than the depth of the member.
- The load is generally uniformly distributed.
- The shear due to a point load is not larger than 10% of the shear capacity of the cross section and the maximum shear for the whole beam is not larger than 50% of the shear capacity.

8.2.3.1.2 Reinforced openings

When the requirements in clause 8.2.3.1.1 are not satisfied, web reinforcement may be provided adjacent to the opening to compensate for the removed material. Reinforcement should be carried past the opening for a distance such that the local shear stress caused by force transfer between the reinforcement and the web is not larger than $p_y/\sqrt{3}$.

8.2.3.2 *Members with reinforced isolated openings*

8.2.3.2.1 Local buckling

Compression elements should be checked against local plate buckling as given in clauses 7.5 or 7.7.

8.2.3.2.2 Shear

Secondary Vierendeel moments due to shear forces at openings should be considered.

The shear stress at an opening should not exceed $\rho_y/\sqrt{3}$.

8.2.3.2.3 Moment capacity

The moment capacity of the cross-section should be determined from the net sectional properties and allowing for the Vierendeel moments due to shear at opening.

8.2.3.2.4 Point loads

Load bearing stiffeners should be provided when a point load is closer to an opening than the depth of the member. When the point load is within the opening, reference should be made to specialist literature or a detailed analysis should be carried out using the finite element method.

8.2.3.2.5 Deflection

Additional deflections caused by the removal of material at the opening should be considered.

8.2.3.3 *Members with reinforced multiple openings*

8.2.3.3.1 Local buckling

Compression elements should be checked against local plate buckling as given in clause 7.5 or 7.7.

8.2.3.3.2 Shear

Secondary Vierendeel moments due to shear forces at openings should be considered.

Shear stresses at openings should not exceed $\rho_y/\sqrt{3}$. The shear stress across a web post between two openings, based on the shear area of the web post at its narrowest point, should not be larger than $0.7\rho_y$.

8.2.3.3.3 Moment capacity

The moment capacity of the cross-section should be determined from the net sectional properties allowing for the Vierendeel moments caused by shear at openings.

8.2.3.3.4 Point loads

The load capacity and buckling resistance of the web should be checked in accordance with clauses 8.2.3.2.4 and 8.4 for the provision of stiffeners. When the point load is within the opening, reference should be made to specialist literature or a detailed analysis should be carried out using the finite element method.

8.2.3.3.5 Deflection

Additional deflections caused by the removal of material at the opening should be considered.

8.2.3.3.6 Web posts

Stability of web posts between openings and at ends of members should be checked and stiffeners should be provided when necessary.

8.2.4 **Castellated beams**

Typical castellated beams as shown in Figure 8.1 are fabricated from rolled I- or H-sections or from channels. The web posts are assumed to be stable when the ratio d/t is not larger than 70ε . This does not apply to castellated beams with other types of openings nor to opening of other shapes.

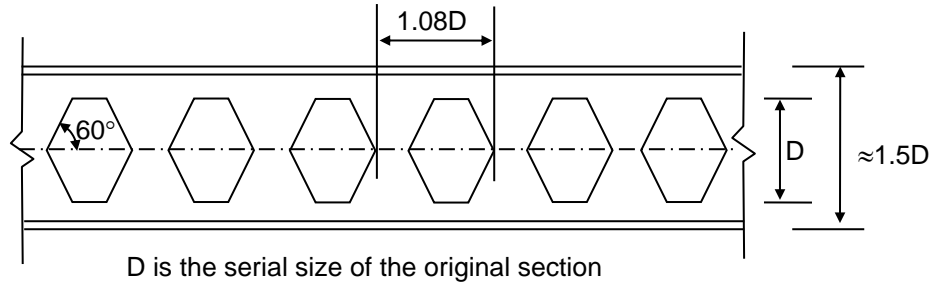

Figure 8.1 - Standard castellated beams

8.3 LATERAL-TORSIONAL BUCKLING OF BEAMS

When the condition for full lateral restraint given in clause 8.2 cannot be satisfied, the resistance of beams to lateral-torsional buckling should be checked. The designer should refer to specialist literature or to carry out a finite element buckling analysis for the buckling of beams with web openings.

8.3.1 Intermediate and end lateral restraints

Restraints, such as those shown in Figure 8.2, may be provided to reduce the effective length of a beam and to increase its buckling resistance moment. These restraints must have adequate stiffness and strength to prevent lateral movement of the compression flange of the beam. The restraints should be as close as practical to the shear centre of the compression flange of the beam. However, if torsional restraint is also provided at the same cross section, the intermediate lateral restraint may be connected at other levels of the section.

The strength requirement for a lateral restraint is 2.5% of the maximum force in the compression flange, or conservatively, 2.5% of its squash load. When more than one lateral restraint is provided at different locations along a beam, the sum of forces provided by these restraints should not be less than 2.5% of the compression flange force and each restraint should provide not less than 1% of the maximum force in the compression flange.

When a bracing system provides lateral restraint to a number of beams, the system should have adequate strength to resist the sum of the 2.5% restraining forces for the maximum forces in compression flanges of these beams, reduced by the factor k_r below:

$$k_r = \sqrt{0.2 + \frac{1}{N_r}} \leq 1 \quad (8.13)$$

in which N_r is the total number of parallel members restrained.

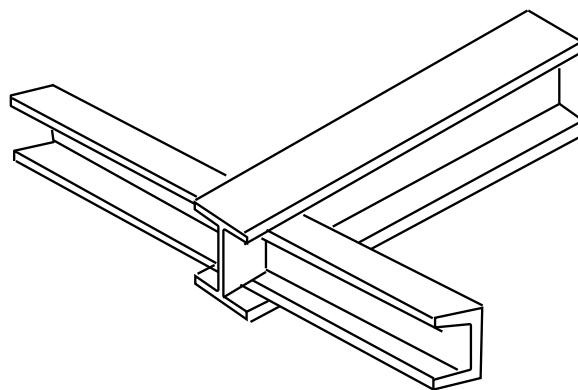

Figure 8.2 - Restraint at end of a cantilever to reduce its effective length

8.3.2 Torsional restraint

Torsional restraint refers to restraint against rotation about the member longitudinal z-axis. It may be provided at any section along a beam or at supports by restraining the lateral movement of both flanges using a pair of lateral restraints as in clause 8.3.1. The strength requirement should satisfy clause 8.3.1 for lateral restraints.

8.3.3 Normal and destabilizing loads

A destabilizing loading condition should be assumed when considering effective length of beams with the dominant loads applied to the top flange and with both the loads and the flange free to deflect and rotate relative to the shear centre of the cross-section. Special consideration and a further reduction should be taken for cases where the loads are applied at a significant distance above the top flange of the beam. Other cases not subject to these conditions should be assumed to be a normal loading condition.

8.3.4 Effective length for lateral-torsional buckling

8.3.4.1 *Simple beams without intermediate lateral restraints*

- (a) For a beam under normal loading conditions with its compression flange restrained against lateral movement at the end supports, but free to rotate on plan and with ends under nominal torsional restraint about the longitudinal axis of the beam at the end supports, the effective length is 1.0 of the span of the beam, i.e.

$$L_E = L_{LT} \quad (8.14)$$

- (b) For a beam under normal loading conditions with the compression flange fully restrained against rotation on plan at its end supports, the effective length can be taken as:

$$L_E = 0.8L_{LT} \quad (8.15)$$

- (c) For a beam under normal loading conditions with compression flanges unrestrained against lateral movement at end supports and with both flanges free to rotate on plan, the effective length is the sum of 1.2 times the span of the beam and 2 times the beam depth, i.e.

$$L_E = 1.2L_{LT} + 2D \quad (8.16)$$

- (d) For beams under destabilizing loads, the effective length should be multiplied by a factor of 1.2.

in which L_{LT} is the segment length between lateral restraints under consideration.

8.3.4.2 *Beams with intermediate lateral restraints*

For simple beams with adequate intermediate lateral restraints satisfying clause 8.3.1, the effective length L_E is normally taken as $1.0L_{LT}$ for a normal load or $1.2L_{LT}$ for a destabilising load. For beams with one end supported and the other end restrained laterally, the effective length should be taken as the mean value of the effective length in clause 8.3.4.1 and this clause.

8.3.4.3 *Cantilevers*

8.3.4.3.1 Cantilevers without intermediate restraints

The effective length of a cantilever without intermediate restraint can be taken from Table 8.1 with the following additional considerations:

When a dominant moment exists at the cantilever tip the effective length is increased by the greater of 30% of its original effective length or an addition of $0.3L$ to the effective length where L is the length of the cantilever.

8.3.4.3.2 Cantilevers with intermediate lateral restraint

The effective length is taken as the segment length between lateral restraints when conditions in either case c) 4) or d) 4) of Table 8.1 are met and the cantilever is under normal load. For other conditions, refer to Table 8.1 with the length between segments being taken as the length of the cantilever.

Table 8.1 - Effective length of cantilever without intermediate restraints

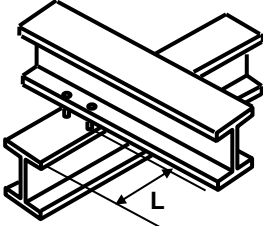
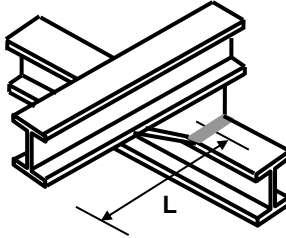
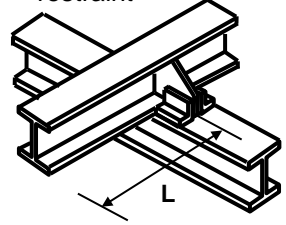
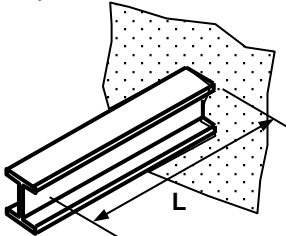
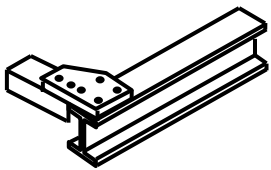
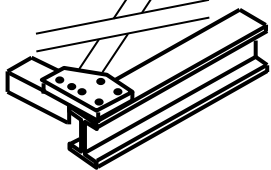
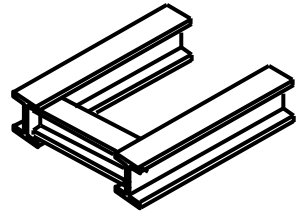
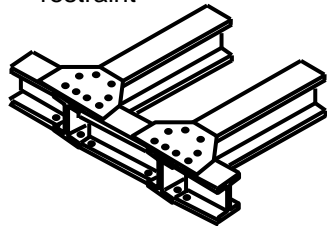
Restraint condition		Loading condition	
At support	At tip	Normal	Destabilizing
a) continuous, with lateral restraint to top flange 	1) Free 2) Lateral restraint to top flange 3) Torsional restraint 4) Lateral and torsional restraint	3.0L 2.7L 2.4L 2.1L	7.5L 7.5L 4.5L 3.6L
b) continuous, with partial torsional restraint 	1) Free 2) Lateral restraint to top flange 3) Torsional restraint 4) Lateral and torsional restraint	2.0L 1.8L 1.6L 1.4L	5.0L 5.0L 3.0L 2.4L
c) continuous, with lateral and torsional restraint 	1) Free 2) Lateral restraint to top flange 3) Torsional restraint 4) Lateral and torsional restraint	1.0L 0.9L 0.8L 0.7L	2.5L 2.5L 1.5L 1.2L
d) restrained laterally and torsionally and against rotation on plan 	1) Free 2) Lateral restraint to top flange 3) Torsional restraint 4) Lateral and torsional restraint	0.8L 0.7L 0.6L 0.5L	1.4L 1.4L 0.6L 0.5L
Tip restraint conditions			
1) Free  (not braced on plan)	2) Lateral restraint to top flange bracing  (braced on plan in one or more bay)	3) Torsional restraint  (not braced on plan)	4) Lateral and torsional restraint  (braced on plan in one or more bay)

8.3.5 Moment resistance to lateral-torsional buckling

8.3.5.1 Limiting slenderness

Lateral-torsional buckling need not be checked in the following cases:

Bending about the minor axis;

CHS, SHS or circular or square solid sections;

RHS with L_E/r_y for relevant value of D/B ratio not exceeding the values in Table 8.2;

I-, H-, channel or box sections with λ_{LT} not exceeding values in the bottom row of Table 8.3.

Table 8.2 - limiting value of L_E/r_y for RHS

Ratio D/B	Limiting value of L_E/r_y		Ratio D/B	Limiting value of L_E/r_y		Ratio D/B	Limiting value of L_E/r_y
1.25	$770 \varepsilon^2$		1.50	$515 \varepsilon^2$		2.0	$340 \varepsilon^2$
1.33	$670 \varepsilon^2$		1.67	$435 \varepsilon^2$		2.5	$275 \varepsilon^2$
1.40	$580 \varepsilon^2$		1.75	$410 \varepsilon^2$		3.0	$225 \varepsilon^2$
1.44	$550 \varepsilon^2$		1.80	$395 \varepsilon^2$		4.0	$170 \varepsilon^2$

Key:
 B is the width of the section;
 D is the depth of the section;
 L_E is the effective length for lateral-torsional buckling from clause 8.3.4;
 p_y is the design strength in section 3;
 r_y is the radius of gyration of the section about its minor axis;
 $\varepsilon = \sqrt{275/p_y}$

The following design procedure should be followed for the design of prismatic and I-, H- and channel sections with equal flanges and of slenderness ratio larger than the limiting slenderness ratio in the bottom rows of Tables 8.3a to 8.3c. For other sections with unequal flanges, varying sections along their length, substantial opening at various locations and unsymmetrical cross-sections, reference should be made to other recognized literature. Alternatively, a buckling analysis may be carried out allowing various factors such as load height, boundary conditions and material properties can be used for computation of critical bending moment M_{cr} and equivalent slenderness as,

$$\lambda_{LT} = \sqrt{\frac{M_p \pi^2 E}{M_{cr} p_y}} \quad (8.17)$$

where M_p is the plastic moment of the section

8.3.5.2 Buckling resistance moment

In each segment of a beam, the buckling resistance moment M_b should satisfy the following.

$$m_{LT}M_x \leq M_b \text{ and} \quad (8.18)$$

$$M_x \leq M_{cx} \quad (8.19)$$

where

m_{LT} is the equivalent uniform moment factor for lateral-torsional buckling of simple beams from Table 8.4. Conservatively it can be taken as unity. For cantilevers, m_{LT} is equal to 1.

M_x = Maximum bending moment along the beam

For Class 1 plastic and Class 2 compact sections:

$$M_b = p_b S_x \quad (8.20)$$

For Class 3 semi-compact sections:

$$M_b = p_b Z_x \text{ or} \quad (8.21)$$

$$M_b = p_b S_{eff} \quad (8.22)$$

For Class 4 slender sections:

$$M_b = p_b Z_{x,eff} \text{ or} \quad (8.23)$$

$$M_b = p_b \frac{p_{yr}}{p_y} Z_x \quad (8.24)$$

S_{eff} is the effective plastic modulus of the section using the effective width method;

$Z_{y,eff}$ is the effective elastic modulus of the section using the effective width method and

p_{yr} is the design strength allowing for local plate buckling in the effective stress method.

p_b is the buckling strength of the beam, determined from Table 8.3a for hot-rolled sections and Table 8.3b for welded sections using a suitable equivalent slenderness λ_{LT} in clause 8.3.5.3 and relevant design strength p_y .

When high strength steel is used, the use of a Class 4 slender section is not permitted.

Alternatively, formulae in Appendix 8.1 may be used to compute p_b .

Table 8.3a - Bending strength p_b (N/mm²) for rolled sections

λ_{LT}	Steel grade and design strength p_y (N/mm ²)														
	S275					S355					S460				
	235	245	255	265	275	315	325	335	345	355	400	410	430	440	460
25	235	245	255	265	275	315	325	335	345	355	400	410	430	440	460
30	235	245	255	265	275	315	325	335	345	355	395	403	421	429	446
35	235	245	255	265	273	307	316	324	332	341	378	386	402	410	426
40	229	238	246	254	262	294	302	309	317	325	359	367	382	389	404
45	219	227	235	242	250	280	287	294	302	309	340	347	361	367	381
50	210	217	224	231	238	265	272	279	285	292	320	326	338	344	356
55	199	206	213	219	226	251	257	263	268	274	299	305	315	320	330
60	189	195	201	207	213	236	241	246	251	257	278	283	292	296	304
65	179	185	190	196	201	221	225	230	234	239	257	261	269	272	279
70	169	174	179	184	188	206	210	214	218	222	237	241	247	250	256
75	159	164	168	172	176	192	195	199	202	205	219	221	226	229	234
80	150	154	158	161	165	178	181	184	187	190	201	203	208	210	214
85	140	144	147	151	154	165	168	170	173	175	185	187	190	192	195
90	132	135	138	141	144	153	156	158	160	162	170	172	175	176	179
95	124	126	129	131	134	143	144	146	148	150	157	158	161	162	164
100	116	118	121	123	125	132	134	136	137	139	145	146	148	149	151
105	109	111	113	115	117	123	125	126	128	129	134	135	137	138	140
110	102	104	106	107	109	115	116	117	119	120	124	125	127	128	129
115	96	97	99	101	102	107	108	109	110	111	115	116	118	118	120
120	90	91	93	94	96	100	101	102	103	104	107	108	109	110	111
125	85	86	87	89	90	94	95	96	96	97	100	101	102	103	104
130	80	81	82	83	84	88	89	90	90	91	94	94	95	96	97
135	75	76	77	78	79	83	83	84	85	85	88	88	89	90	90
140	71	72	73	74	75	78	78	79	80	80	82	83	84	84	85
145	67	68	69	70	71	73	74	74	75	75	77	78	79	79	80
150	64	64	65	66	67	69	70	70	71	71	73	73	74	74	75
155	60	61	62	62	63	65	66	66	67	67	69	69	70	70	71
160	57	58	59	59	60	62	62	63	63	63	65	65	66	66	67
165	54	55	56	56	57	59	59	59	60	60	61	62	62	62	63
170	52	52	53	53	54	56	56	56	57	57	58	58	59	59	60
175	49	50	50	51	51	53	53	53	54	54	55	55	56	56	56
180	47	47	48	48	49	50	51	51	51	51	52	53	53	53	54
185	45	45	46	46	46	48	48	48	49	49	50	50	50	51	51
190	43	43	44	44	44	46	46	46	46	47	48	48	48	48	48
195	41	41	42	42	42	43	44	44	44	44	45	45	46	46	46
200	39	39	40	40	40	42	42	42	42	42	43	43	44	44	44
210	36	36	37	37	37	38	38	38	39	39	39	40	40	40	40
220	33	33	34	34	34	35	35	35	35	36	36	36	37	37	37
230	31	31	31	31	31	32	32	33	33	33	33	33	34	34	34
240	28	29	29	29	29	30	30	30	30	30	31	31	31	31	31
250	26	27	27	27	27	28	28	28	28	28	29	29	29	29	29
λ_{L0}	37.1	36.3	35.6	35.0	34.3	32.1	31.6	31.1	30.6	30.2	28.4	28.1	27.4	27.1	26.5

λ_{L0} is the maximum slenderness ratio of the member having negligible buckling effect.

Table 8.3b - Bending strength p_b (N/mm²) for welded sections

(i) S275 ~ S460 steel

λ_{LT}	Steel grade and design strength p_y (N/mm ²)														
	S275					S355					S460				
	235	245	255	265	275	315	325	335	345	355	400	410	430	440	460
25	235	245	255	265	275	315	325	335	345	355	400	410	430	440	460
30	235	245	255	265	275	315	325	335	345	355	390	397	412	419	434
35	235	245	255	265	272	300	307	314	321	328	358	365	378	385	398
40	224	231	237	244	250	276	282	288	295	301	328	334	346	352	364
45	206	212	218	224	230	253	259	265	270	276	300	306	316	321	332
50	190	196	201	207	212	233	238	243	248	253	275	279	288	293	302
55	175	180	185	190	195	214	219	223	227	232	251	255	263	269	281
60	162	167	171	176	180	197	201	205	209	212	237	242	253	258	269
65	150	154	158	162	166	183	188	194	199	204	227	232	242	247	256
70	139	142	146	150	155	177	182	187	192	196	217	222	230	234	242
75	130	135	140	145	151	170	175	179	184	188	207	210	218	221	228
80	126	131	136	141	146	163	168	172	176	179	196	199	205	208	214
85	122	127	131	136	140	156	160	164	167	171	185	187	190	192	195
90	118	123	127	131	135	149	152	156	159	162	170	172	175	176	179
95	114	118	122	125	129	142	144	146	148	150	157	158	161	162	164
100	110	113	117	120	123	132	134	136	137	139	145	146	148	149	151
105	106	109	112	115	117	123	125	126	128	129	134	135	137	138	140
110	101	104	106	107	109	115	116	117	119	120	124	125	127	128	129
115	96	97	99	101	102	107	108	109	110	111	115	116	118	118	120
120	90	91	93	94	96	100	101	102	103	104	107	108	109	110	111
125	85	86	87	89	90	94	95	96	96	97	100	101	102	103	104
130	80	81	82	83	84	88	89	90	90	91	94	94	95	96	97
135	75	76	77	78	79	83	83	84	85	85	88	88	89	90	90
140	71	72	73	74	75	78	78	79	80	80	82	83	84	84	85
145	67	68	69	70	71	73	74	74	75	75	77	78	79	79	80
150	64	64	65	66	67	69	70	70	71	71	73	73	74	74	75
155	60	61	62	62	63	65	66	66	67	67	69	69	70	70	71
160	57	58	59	59	60	62	62	63	63	63	65	65	66	66	67
165	54	55	56	56	57	59	59	59	60	60	61	62	62	62	63
170	52	52	53	53	54	56	56	56	57	57	58	58	59	59	60
175	49	50	50	51	51	53	53	53	54	54	55	55	56	56	56
180	47	47	48	48	49	50	51	51	51	51	52	53	53	53	54
185	45	45	46	46	46	48	48	48	49	49	50	50	50	51	51
190	43	43	44	44	44	46	46	46	46	47	48	48	48	48	48
195	41	41	42	42	42	43	44	44	44	44	45	45	46	46	46
200	39	39	40	40	40	42	42	42	42	42	43	43	44	44	44
210	36	36	37	37	37	38	38	38	39	39	39	40	40	40	40
220	33	33	34	34	34	35	35	35	35	36	36	36	37	37	37
230	31	31	31	31	31	32	32	33	33	33	33	33	34	34	34
240	28	29	29	29	29	30	30	30	30	30	31	31	31	31	31
250	26	27	27	27	27	28	28	28	28	28	29	29	29	29	29
λ_{L0}	37.1	36.3	35.6	35.0	34.3	32.1	31.6	31.1	30.6	30.2	28.4	28.1	27.4	27.1	26.5

λ_{L0} is the maximum slenderness ratio of the member having negligible buckling effect.

Table 8.3b - Bending strength p_b (N/mm²) for welded sections (Cont'd)

(ii) S550 ~ S690 steel

λ_{LT}	Strength grade and design strength p_y (N/mm ²)					
	S550			S690		
	490	530	550	630	650	690
25	490	527	543	606	621	652
30	456	484	499	554	568	595
35	417	443	455	505	517	540
40	381	403	414	457	467	487
45	347	366	375	411	422	446
50	315	334	345	391	401	422
55	297	319	329	369	378	396
60	284	303	312	345	353	368
65	269	285	293	321	327	339
70	254	267	274	294	297	303
75	238	248	252	264	267	272
80	219	226	228	239	241	245
85	200	205	208	216	218	221
90	183	187	189	196	198	201
95	168	171	173	179	180	183
100	154	157	159	164	165	167
105	142	145	146	150	151	153
110	131	134	135	138	139	141
115	121	124	125	128	129	130
120	113	115	115	118	119	120
125	105	107	107	110	110	111
130	98	99	100	102	103	104
135	92	93	93	95	96	97
140	86	87	87	89	90	90
145	80	82	82	84	84	85
150	76	77	77	79	79	79
155	71	72	73	74	74	75
160	67	68	68	70	70	70
165	64	64	65	66	66	66
170	60	61	61	62	62	63
175	57	58	58	59	59	59
180	54	55	55	56	56	56
185	51	52	52	53	53	53
190	49	49	50	50	51	51
195	47	47	47	48	48	48
200	44	45	45	46	46	46
210	41	41	41	42	42	42
220	37	37	38	38	38	38
230	34	34	35	35	35	35
240	32	32	32	32	32	32
250	29	29	29	30	30	30
λ_{L0}	25.7	24.7	24.3	22.7	22.3	21.7

Table 8.3c - Bending strength p_b (N/mm²) for other steel source

(i) Bending strength for rolled sections

λ_{LT}	Steel grade and design strength (N/mm ²)							
	Q235	Q345/Q355	Q390	Q420	Q460	Q550	Q690	
	215	305	345	375	410	520	615	630
25	215	305	345	375	410	520	604	618
30	215	305	345	373	403	497	577	589
35	215	299	332	357	386	473	546	557
40	212	286	317	340	367	447	512	522
45	204	272	302	323	347	419	475	484
50	195	259	285	305	326	389	436	443
55	186	245	268	286	305	358	396	402
60	177	230	251	266	283	327	358	363
65	168	216	234	247	261	298	323	326
70	159	202	218	229	241	271	291	294
75	150	188	202	211	221	246	262	264
80	141	175	187	195	203	224	237	239
85	133	163	173	180	187	204	215	216
90	125	151	160	166	172	186	195	196
95	118	141	148	153	158	171	178	179
100	111	131	137	142	146	157	163	164
105	104	122	128	131	135	144	150	150
110	98	114	119	122	125	133	138	138
115	92	106	110	113	116	123	127	128
120	87	99	103	106	108	114	118	118
125	82	93	96	99	101	106	109	110
130	77	87	90	92	94	99	102	102
135	73	82	85	86	88	93	95	95
140	69	77	80	81	83	87	89	89
145	65	73	75	76	78	81	83	84
150	62	69	71	72	73	76	78	79
155	59	65	67	68	69	72	74	74
160	56	61	63	64	65	68	69	70
165	53	58	60	61	62	64	66	66
170	50	55	57	58	58	61	62	62
175	48	52	54	55	55	57	59	59
180	46	50	51	52	53	55	56	56
185	44	47	49	49	50	52	53	53
190	42	45	46	47	48	49	50	50
195	38	43	44	45	45	47	48	48
200	38	41	42	43	43	45	46	46
210	35	38	39	39	40	41	42	42
220	32	35	35	36	36	37	38	38
230	30	32	33	33	33	34	35	35
240	28	30	30	31	31	32	32	32
250	26	27	28	28	29	29	30	30
λ_{L0}	38.8	32.3	30.6	29.4	28.1	25.0	22.9	22.7

λ_{L0} is the maximum slenderness ratio of the member having negligible buckling effect.

Table 8.3c - Bending strength p_b (N/mm²) for other steel source

(ii) Bending strength for welded sections

λ_{LT}	Steel grade and design strength (N/mm ²)							
	Q235	Q345/Q355	Q390	Q420	Q460	Q550	Q690	
	215	305	345	375	410	520	615	630
25	215	305	345	375	410	520	594	606
30	215	305	345	371	397	477	544	554
35	215	293	321	341	365	437	496	505
40	211	269	295	313	334	398	449	457
45	194	248	270	287	306	361	405	411
50	179	228	248	263	279	328	382	391
55	165	209	227	240	255	314	362	369
60	153	193	209	223	242	298	340	345
65	141	177	199	215	232	281	316	321
70	131	171	192	206	222	264	291	294
75	122	165	184	197	210	246	262	264
80	116	159	176	187	199	224	237	239
85	113	152	167	177	187	204	215	216
90	109	146	159	166	172	186	195	196
95	106	139	148	153	158	171	178	179
100	102	131	137	142	146	157	163	164
105	99	122	128	131	135	144	150	150
110	95	114	119	122	125	133	138	138
115	91	106	110	113	116	123	127	128
120	87	99	103	106	108	114	118	118
125	82	93	96	99	101	106	109	110
130	77	87	90	92	94	99	102	102
135	73	82	85	86	88	93	95	95
140	69	77	80	81	83	87	89	89
145	65	73	75	76	78	81	83	84
150	62	69	71	72	73	76	78	79
155	59	65	67	68	69	72	74	74
160	56	61	63	64	65	68	69	70
165	53	58	60	61	62	64	66	66
170	50	55	57	58	58	61	62	62
175	48	52	54	55	55	57	59	59
180	46	50	51	52	53	55	56	56
185	44	47	49	49	50	52	53	53
190	42	45	46	47	48	49	50	50
195	40	43	44	45	45	47	48	48
200	38	41	42	43	43	45	46	46
210	35	38	39	39	40	41	42	42
220	32	35	35	36	36	37	38	38
230	30	32	33	33	33	34	35	35
240	28	30	30	31	31	32	32	32
250	26	27	28	28	29	29	30	30
λ_{L0}	38.8	32.3	30.6	29.4	28.1	25.0	22.9	22.7

λ_{L0} is the maximum slenderness ratio of the member having negligible buckling effect.

Table 8.4a - Equivalent uniform moment factor m_{LT} for lateral-torsional buckling of beams under end moments and typical loads

Segment with end moment only (values of m_{LT} from the formula for the general case)	β	m_{LT}
<p>β positive</p> 	1.0	1.00
	0.9	0.96
	0.8	0.92
	0.7	0.88
	0.6	0.84
	0.5	0.80
	0.4	0.76
	0.3	0.72
	0.2	0.68
	0.1	0.64
<p>X lateral restraint</p> <p>β negative</p> 	0.0	0.60
	-0.1	0.56
	-0.2	0.52
	-0.3	0.48
	-0.4	0.46
	-0.5	0.44
	-0.6	0.44
	-0.7	0.44
	-0.8	0.44
	-0.9	0.44
-1.0	0.44	
Special case (no intermediate lateral restraint)		
 <p style="text-align: center;">$m_{LT} = 0.85$</p>	 <p style="text-align: center;">$m_{LT} = 0.93$</p>	
 <p style="text-align: center;">$m_{LT} = 0.93$</p>	 <p style="text-align: center;">$m_{LT} = 0.74$</p>	

Table 8.4b - Equivalent uniform moment factor m_{LT} for lateral-torsional buckling of beams under non-typical loads

General case (segment between intermediate lateral restraint)	
	
<p>For beams: $m_{LT} = 0.2 + \frac{0.15M_2 + 0.5M_3 + 0.15M_4}{M_{max}}$ but $m_{LT} \geq 0.44$</p> <p>All moments are taken as positive. The moments M_2 and M_4 are the values at the quarter points, M_3 is the value at mid-length and M_{max} is the maximum moment in the segment.</p>	
<p>For cantilevers without intermediate lateral restraint, $m_{LT} = 1.00$</p>	

8.3.5.3 Equivalent slenderness for flexural-torsional buckling λ_{LT}

The equivalent slenderness λ_{LT} should be obtained as follows.

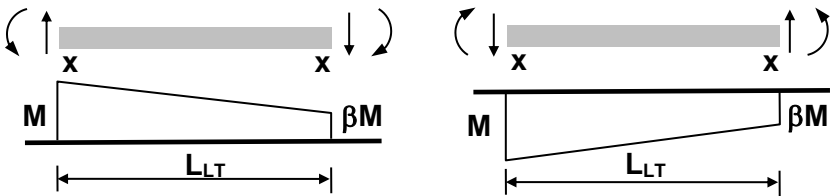
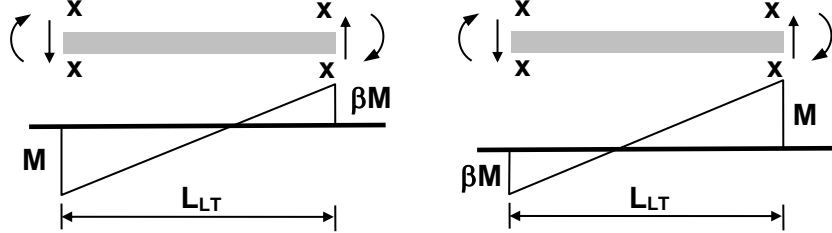
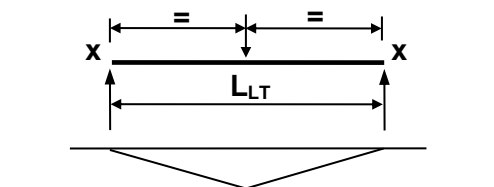
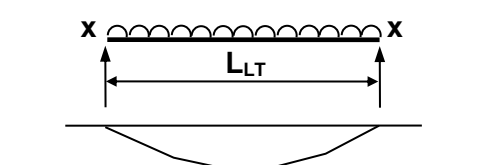
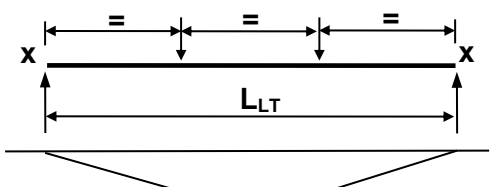
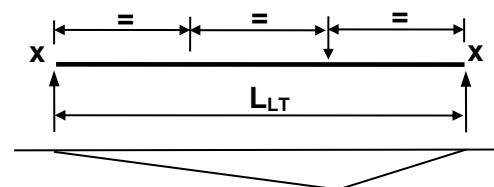
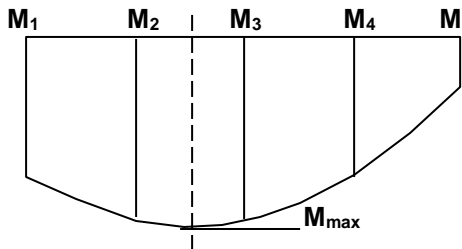
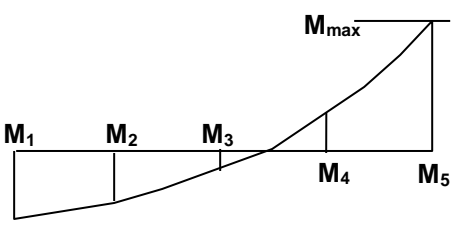
$$\lambda_{LT} = u v \lambda \sqrt{\beta_w} \tag{8.25}$$

where

$$\lambda = \frac{L_E}{r_y} \tag{8.26}$$

L_E is the effective length for lateral-torsional buckling from clause 8.3.4

r_y is the radius of gyration about the minor y-axis

u is the buckling parameter from Appendix 8.2 or conservatively equal to 0.9 for hot-rolled sections and 1.0 for welded sections

v is the slenderness factor given by,

$$v = \frac{1}{(1 + 0.05(\lambda/x)^2)^{0.25}} \tag{8.27}$$

x is the torsional index from Appendix 8.2 or conservatively as D/T

D is the depth of the section

T is the thickness of the flange

β_w is the ratio defined as,

$\beta_w = 1.0$ for Class 1 plastic section and Class 2 compact section,

$$\beta_w = \frac{Z_x}{S_x} \text{ or } \frac{S_{x,eff}}{S_x} \text{ for Class 3 semi-compact sections and} \tag{8.28}$$

$$\beta_w = \frac{Z_{x,eff}}{S_x} \text{ for Class 4 slender sections} \tag{8.29}$$

Lateral-torsional buckling design of channels can be based on clause 8.3.5.3, provided that the loads pass through the shear centre and that boundary conditions apply at the shear centre.

8.4 PLATE GIRDERS

8.4.1 Design strength

For the simple design of plate girders, the webs are generally assumed to take shear, transverse and axial forces and flanges are assumed to resist moment. The material design strength in section 3 should be used when the web and the flanges are of the same steel grade.

When web and flanges are of different steel grades and the web design strength p_{yw} is greater than the flange design strength p_{yf} , p_{yf} should be used for moment, axial force and shear checking. When p_{yw} is less than p_{yf} , the steel grades for flange (p_{yf}) should be used for axial force and moment checks and the strength of the web (p_{yw}) should be used for shear and transverse force checks.

8.4.2 Minimum web thickness for serviceability

For serviceability requirements, the d/t ratio of the web in a plate girder should satisfy the following conditions:

For webs without intermediate stiffeners, $t \geq d/250$; (8.30)

For webs with transverse stiffeners only,

(a) When stiffener spacing $a > d$, $t \geq d/250$ (8.31)

(b) When stiffener spacing $a \leq d$, $t \geq d/250 \sqrt{\frac{a}{d}}$ (8.32)

in which,

a is the spacing of stiffeners;

d is the depth of web.

Reference should be made to specialist literature for webs having both longitudinal and transverse stiffeners.

8.4.3 Minimum web thickness to avoid compression flange buckling

To prevent compression flange buckling into the web, the following conditions need to be satisfied:-

(a) For webs without intermediate transverse stiffeners or with stiffeners at spacing $a > 1.5d$, $t \geq d/250 \times \frac{p_{yf}}{345}$ (8.33)

(b) For webs with intermediate transverse stiffeners at spacing $a \leq 1.5d$, $t \geq d/250 \sqrt{\frac{p_{yf}}{455}}$ (8.34)

where p_{yf} is the design strength of the compression flange.

8.4.4 Moment capacity of restrained girders

8.4.4.1 Web not susceptible to shear buckling

If the web depth-to-thickness ratio $d/t \leq 62\varepsilon$, shear buckling need not be considered and the methods for beam design in clause 8.2 should be followed to determine the moment capacity.

8.4.4.2 Web susceptible to shear buckling

If the web depth-to-thickness ratio $d/t > 70\varepsilon$ for hot-rolled section or $d/t > 62\varepsilon$ for welded sections, shear buckling should be considered and the following methods should be used to determine the moment resistance:

- (a) Low shear load:
The low shear load condition is assumed when $V \leq 0.6 V_w$. The girder should be designed to clause 8.2 as for rolled section beams.
- (b) High shear load:
The high shear load condition is assumed when $V > 0.6 V_w$. Provided that the flanges are not Class 4 slender, the moment capacity of the girder is equal to the moment capacity provided by flanges alone, i.e.

$$M_p = p_{yf} B T (D - T) \quad (8.35)$$

where V_w is the shear buckling resistance determined from clause 8.4.6 ignoring contribution from flanges.

Alternative methods given in other codes can be used when the contribution of webs to moment capacity is allowed for.

8.4.5 Effects of axial force

Additional stress caused by axial force should be added to the bending stress in flanges calculated in clause 8.4.4.2 and the resultant stress should not be larger than p_{yf} .

8.4.6 Shear buckling resistance

If the web depth-to-thickness ratio $d/t > 70\epsilon$ for hot-rolled section or $d/t > 62\epsilon$ for welded sections, shear buckling should be checked.

The shear buckling resistance V_w of a web with or without web stiffeners should be taken as,

$$V_w = d t q_w \quad (8.36)$$

in which

d is the depth of the web,

t is the web thickness,

q_w is the shear buckling strength of the web depending on d/t and a/d ratios and obtained from Tables 8.5a - 8.5l or Appendix 8.3.

8.4.7 Intermediate transverse web stiffeners

To resist shear buckling in clause 8.4.6, intermediate transverse stiffeners may be used. Intermediate transverse stiffeners may be provided on either one or both sides of the web.

8.4.7.1 Spacing

Where intermediate transverse web stiffeners are provided, their spacing should conform to clauses 8.4.2 and 8.4.3.

8.4.7.2 Outstand of stiffeners

The outstand of the stiffeners should conform to clause 8.4.10.1.

8.4.7.3 Minimum stiffness

Intermediate transverse web stiffeners not subjected to external loads or moments should have a second moment of area I_s about the centreline of the web not less than I_s given by:

$$\text{for } a/d \geq \sqrt{2} : I_s = 0.75 d t_{\min}^3 \quad (8.37)$$

$$\text{for } a/d < \sqrt{2} : I_s = 1.5 (d/a)^2 d t_{\min}^3 \quad (8.38)$$

where

a is the actual stiffener spacing;

d is the depth of the web;

t_{\min} is the minimum required web thickness determined from clauses 8.4.2 and 8.4.3 for the actual stiffener spacing a .

8.4.7.4 Additional stiffness for external loading

If an intermediate transverse web stiffener is subjected to externally applied forces, the required value of I_s given in clause 8.4.7.3 should be increased by adding I_{ext} as follows:

- (a) for transverse forces effectively applied in line with the web:

$$I_{ext} = 0$$

- (b) for transverse forces applied eccentric to the web:

$$I_{ext} = F_x e_x D^2 / Et \quad (8.39)$$

- (c) for lateral forces, deemed to be applied at the level of the compression flange of the girder:

$$I_{ext} = 2F_h D^3 / Et \quad (8.40)$$

where

D is the overall depth of the section;

E is the modulus of elasticity;

e_x is the eccentricity of the transverse force from the centreline of the web;

F_h is the external lateral force;

F_x is the external transverse force;

t is the web thickness.

8.4.7.5 Buckling resistance

Intermediate transverse web stiffeners not subjected to external forces or moments should satisfy the condition:

$$F_q \leq P_q \quad (8.41)$$

in which F_q is the larger value, considering the two web panels on each side of the stiffener, of the compressive axial force given by:

$$F_q = V - V_{cr} \quad (8.42)$$

where

P_q is the buckling resistance of the intermediate web stiffener determined from clause 8.4.10.6.2 except that L_E is taken as $0.7L$ and checking for bearing is not required;

V is the shear in a web panel adjacent to the stiffener;

V_{cr} is the critical shear buckling resistance (see clause 8.4.8b) of the same web panel.

Intermediate transverse web stiffeners subjected to external forces or moments should meet the conditions for load carrying web stiffeners given in clause 8.4.10.6.2. In addition, they should also satisfy the following:

- if $F_q > F_x$:

$$\frac{F_q - F_x}{P_q} + \frac{F_x}{P_x} + \frac{M_s}{M_{ys}} \leq 1 \quad (8.43)$$

- if $F_q \leq F_x$:

$$\frac{F_x}{P_x} + \frac{M_s}{M_{ys}} \leq 1 \quad (8.44)$$

in which

$$M_s = F_x e_x + F_h D \quad (8.45)$$

where

F_h is the external lateral force, if any;

F_x is the external transverse force;

M_{ys} is the moment capacity of the stiffener calculated by its section modulus;

P_x is the buckling resistance of a load carrying stiffener, see clause 8.4.10.6.2.

8.4.7.6 *Connection to web of intermediate stiffeners*

Intermediate transverse web stiffeners that are not subjected to external forces or moments should be connected to the web to withstand the shear between each component and the web (in kN per millimetre run) with length of not less than:-

$$t^2 / (5b_s) \tag{8.46}$$

where

b_s is the outstand of the stiffener (in mm);

t is the web thickness (in mm).

If the stiffeners are subjected to external forces or moments, the resulting shear between the web and the stiffener should be added to the above value.

Intermediate transverse web stiffeners that are not subjected to external forces or moments should extend to the compression flange, but need not be connected to it. Intermediate transverse web stiffeners that are not subjected to external forces or moments may terminate clear of the tension flange. In such cases, the welds connecting the stiffener to the web should terminate not more than $4t$ clear of the tension flange.

Table 8.5a - Shear buckling strength q_w (N/mm²) of a web (for $t \leq 16$ mm)

1) Grade S275 steel, web thickness ≤ 16 mm – design strength $p_y = 275$ N/mm ²															
d/t	Stiffener spacing ratio a/d														
	0.4	0.5	0.6	0.7	0.8	0.9	1.0	1.2	1.4	1.6	1.8	2.0	2.5	3.0	∞
55	165	165	165	165	165	165	165	165	165	165	165	165	165	165	165
60	165	165	165	165	165	165	165	165	165	165	165	165	165	165	165
65	165	165	165	165	165	165	165	165	165	165	165	165	165	165	161
70	165	165	165	165	165	165	165	165	165	165	164	162	160	158	155
75	165	165	165	165	165	165	165	165	163	160	158	156	154	152	148
80	165	165	165	165	165	165	165	162	157	154	152	150	147	146	142
85	165	165	165	165	165	165	162	156	152	149	146	144	141	139	135
90	165	165	165	165	165	163	157	151	146	143	140	138	135	133	128
95	165	165	165	165	165	158	152	146	141	137	134	132	129	127	122
100	165	165	165	165	160	154	147	140	135	131	128	126	123	120	116
105	165	165	165	164	156	149	142	135	129	125	122	120	117	115	110
110	165	165	165	160	152	144	137	130	124	120	117	115	111	109	105
115	165	165	165	156	147	139	132	124	118	114	112	110	106	105	101
120	165	165	163	152	143	135	128	119	113	110	107	105	102	100	96
125	165	165	159	148	139	130	123	114	109	105	103	101	98	96	92
130	165	165	156	145	134	125	118	110	105	101	99	97	94	93	89
135	165	165	152	141	130	121	113	106	101	97	95	93	91	89	86
140	165	162	149	137	126	116	109	102	97	94	92	90	87	86	83
145	165	159	145	133	121	112	105	98	94	91	88	87	84	83	80
150	165	156	142	129	117	109	102	95	91	88	86	84	82	80	77
155	165	153	138	125	113	105	99	92	88	85	83	81	79	78	75
160	165	150	135	121	110	102	96	89	85	82	80	79	76	75	72
165	165	147	131	117	107	99	93	86	82	80	78	76	74	73	70
170	162	144	128	114	103	96	90	84	80	77	75	74	72	71	68
175	160	141	124	110	100	93	87	81	78	75	73	72	70	69	66
180	157	138	121	107	98	90	85	79	76	73	71	70	68	67	64
185	155	135	117	104	95	88	83	77	73	71	69	68	66	65	62
190	152	132	114	102	93	86	80	75	72	69	68	66	64	63	61
195	150	129	111	99	90	84	78	73	70	67	66	65	63	62	59
200	147	126	109	97	88	81	76	71	68	66	64	63	61	60	58
205	145	123	106	94	86	79	75	70	66	64	63	61	60	59	56
210	142	120	103	92	84	78	73	68	65	63	61	60	58	57	55
215	140	117	101	90	82	76	71	66	63	61	60	59	57	56	54
220	137	115	99	88	80	74	70	65	62	60	58	57	56	55	53
225	135	112	97	86	78	72	68	63	60	58	57	56	54	53	51
230	132	110	94	84	76	71	66	62	59	57	56	55	53	52	50
235	130	107	92	82	75	69	65	61	58	56	55	54	52	51	49
240	128	105	90	80	73	68	64	59	57	55	53	52	51	50	48
245	125	103	89	79	72	66	62	58	55	54	52	51	50	49	47
250	123	101	87	77	70	65	61	57	54	53	51	50	49	48	46

Note : For other steel grades not covered in Table 8.5, refer to Appendix 8.3.

Table 8.5b - Shear buckling strength q_w (N/mm²) of a web (for 16mm < $t \leq 40$ mm)

2) Grade S275 steel, web thickness >16mm ≤ 40mm – design strength $p_y = 265$ N/mm ²															
d/t	Stiffener spacing ratio a/d														
	0.4	0.5	0.6	0.7	0.8	0.9	1.0	1.2	1.4	1.6	1.8	2.0	2.5	3.0	∞
55	159	159	159	159	159	159	159	159	159	159	159	159	159	159	159
60	159	159	159	159	159	159	159	159	159	159	159	159	159	159	159
65	159	159	159	159	159	159	159	159	159	159	159	159	159	159	157
70	159	159	159	159	159	159	159	159	159	159	159	159	158	156	154
75	159	159	159	159	159	159	159	159	159	156	154	152	150	148	145
80	159	159	159	159	159	159	159	157	153	150	148	147	144	142	138
85	159	159	159	159	159	159	158	152	148	145	143	141	138	136	132
90	159	159	159	159	159	158	153	147	143	139	137	135	132	130	126
95	159	159	159	159	159	154	149	142	137	134	131	129	126	124	120
100	159	159	159	159	156	150	144	137	132	128	126	124	120	118	113
105	159	159	159	159	152	145	139	132	127	123	120	118	114	112	108
110	159	159	159	156	148	141	134	127	121	117	114	112	109	107	103
115	159	159	159	152	144	136	130	122	116	112	110	108	104	103	99
120	159	159	158	149	140	132	125	117	111	108	105	103	100	98	95
125	159	159	155	145	136	127	120	112	107	103	101	99	96	94	91
130	159	159	152	141	132	123	116	108	103	99	97	95	92	91	87
135	159	159	148	137	127	119	111	104	99	96	93	92	89	87	84
140	159	158	145	134	123	114	107	100	95	92	90	88	86	84	81
145	159	155	142	130	119	110	104	97	92	89	87	85	83	81	78
150	159	152	139	126	115	107	100	93	89	86	84	82	80	79	76
155	159	149	135	122	111	103	97	90	86	83	81	80	77	76	73
160	159	147	132	119	108	100	94	87	83	81	79	77	75	74	71
165	159	144	129	115	105	97	91	85	81	78	76	75	73	72	69
170	158	141	125	112	102	94	88	82	78	76	74	73	71	69	67
175	156	138	122	108	99	91	86	80	76	74	72	71	69	67	65
180	153	135	119	105	96	89	83	78	74	72	70	69	67	66	63
185	151	132	115	102	93	86	81	76	72	70	68	67	65	64	61
190	149	129	112	100	91	84	79	74	70	68	66	65	63	62	60
195	146	127	109	97	89	82	77	72	68	66	65	63	62	61	58
200	144	124	107	95	86	80	75	70	67	65	63	62	60	59	57
205	141	121	104	92	84	78	73	68	65	63	61	60	59	58	55
210	139	118	102	90	82	76	71	67	64	61	60	59	57	56	54
215	137	115	99	88	80	74	70	65	62	60	59	58	56	55	53
220	134	112	97	86	78	73	68	64	61	59	57	56	55	54	52
225	132	110	95	84	77	71	67	62	59	57	56	55	53	52	50
230	130	108	93	82	75	70	65	61	58	56	55	54	52	51	49
235	127	105	91	81	73	68	64	60	57	55	54	53	51	50	48
240	125	103	89	79	72	67	63	58	56	54	52	52	50	49	47
245	123	101	87	77	70	65	61	57	54	53	51	50	49	48	46
250	120	99	85	76	69	64	60	56	53	52	50	49	48	47	45

Note : For other steel grades not covered in Table 8.5, refer to Appendix 8.3.

Table 8.5c - Shear buckling strength q_w (N/mm²) of a web (for $t \leq 16$ mm)

3) Grade S355 steel, web thickness ≤ 16 mm – design strength $p_y = 355$ N/mm ²															
d/t	Stiffener spacing ratio a/d														
	0.4	0.5	0.6	0.7	0.8	0.9	1.0	1.2	1.4	1.6	1.8	2.0	2.5	3.0	∞
55	213	213	213	213	213	213	213	213	213	213	213	213	213	213	213
60	213	213	213	213	213	213	213	213	213	213	213	213	209	208	203
65	213	213	213	213	213	213	213	213	212	208	206	204	200	198	193
70	213	213	213	213	213	213	213	209	204	200	197	195	191	189	184
75	213	213	213	213	213	213	209	201	196	191	188	186	182	180	174
80	213	213	213	213	213	209	202	194	187	183	180	177	173	170	164
85	213	213	213	213	211	202	195	186	179	174	171	168	164	161	155
90	213	213	213	213	205	195	187	178	171	166	162	159	155	152	146
95	213	213	213	209	198	189	180	170	163	157	153	151	146	144	138
100	213	213	213	203	192	182	173	162	155	149	146	143	139	137	131
105	213	213	211	197	185	175	165	154	147	142	139	136	132	130	125
110	213	213	206	192	179	168	158	147	140	136	133	130	126	124	119
115	213	213	201	186	173	161	151	141	134	130	127	124	121	119	114
120	213	213	195	180	166	154	145	135	129	124	121	119	116	114	109
125	213	208	190	174	160	148	139	130	124	119	117	115	111	109	105
130	213	204	185	169	154	142	134	125	119	115	112	110	107	105	101
135	213	199	180	163	148	137	129	120	114	111	108	106	103	101	97
140	213	195	175	157	143	132	124	116	110	107	104	102	99	98	94
145	213	190	170	151	138	128	120	112	107	103	101	99	96	94	91
150	209	186	165	146	133	123	116	108	103	100	97	95	93	91	88
155	206	181	159	142	129	119	112	105	100	96	94	92	90	88	85
160	202	177	154	137	125	116	109	101	97	93	91	89	87	85	82
165	198	173	150	133	121	112	105	98	94	91	88	87	84	83	80
170	195	168	145	129	117	109	102	95	91	88	86	84	82	80	77
175	191	164	141	125	114	106	99	93	88	85	83	82	79	78	75
180	187	159	137	122	111	103	97	90	86	83	81	80	77	76	73
185	184	155	133	119	108	100	94	88	83	81	79	77	75	74	71
190	180	151	130	115	105	97	91	85	81	79	77	75	73	72	69
195	176	147	127	113	102	95	89	83	79	77	75	73	71	70	67
200	173	143	123	110	100	93	87	81	77	75	73	72	70	68	66
205	169	140	120	107	97	90	85	79	75	73	71	70	68	67	64
210	165	136	117	104	95	88	83	77	74	71	69	68	66	65	63
215	162	133	115	102	93	86	81	75	72	69	68	67	65	64	61
220	158	130	112	100	91	84	79	74	70	68	66	65	63	62	60
225	155	127	110	98	89	82	77	72	69	66	65	64	62	61	58
230	151	124	107	95	87	80	76	70	67	65	63	62	60	59	57
235	148	122	105	93	85	79	74	69	66	64	62	61	59	58	56
240	145	119	103	91	83	77	72	67	64	62	61	60	58	57	55
245	142	117	101	90	82	76	71	66	63	61	59	58	57	56	54
250	139	115	99	88	80	74	70	65	62	60	58	57	56	55	53

Note : For other steel grades not covered in Table 8.5, refer to Appendix 8.3.

Table 8.5d - Shear buckling strength q_w (N/mm²) of a web (for 16mm < $t \leq 40$ mm)

4) Grade S355 steel, web thickness >16mm ≤ 40mm – design strength $p_y = 345$ N/mm ²															
d/t	Stiffener spacing ratio a/d														
	0.4	0.5	0.6	0.7	0.8	0.9	1.0	1.2	1.4	1.6	1.8	2.0	2.5	3.0	∞
55	207	207	207	207	207	207	207	207	207	207	207	207	207	207	207
60	207	207	207	207	207	207	207	207	207	207	207	207	205	203	199
65	207	207	207	207	207	207	207	207	207	204	201	200	196	194	190
70	207	207	207	207	207	207	207	205	200	196	193	191	187	185	180
75	207	207	207	207	207	207	205	197	192	188	185	183	179	177	171
80	207	207	207	207	207	205	198	190	184	180	176	174	170	168	162
85	207	207	207	207	206	198	191	182	176	172	168	165	161	159	153
90	207	207	207	207	200	192	184	175	168	163	160	157	152	150	144
95	207	207	207	205	194	185	177	167	160	155	151	149	144	142	136
100	207	207	207	199	188	178	170	160	152	147	144	141	137	135	129
105	207	207	206	194	182	172	163	152	145	140	137	134	131	128	123
110	207	207	202	188	176	165	156	145	138	134	131	128	125	123	118
115	207	207	197	182	170	159	149	139	132	128	125	123	119	117	113
120	207	207	192	177	164	152	143	133	127	123	120	118	114	112	108
125	207	204	187	171	158	146	137	128	122	118	115	113	110	108	104
130	207	200	182	166	152	140	132	123	117	113	111	109	105	104	100
135	207	195	177	160	146	135	127	118	113	109	106	105	102	100	96
140	207	191	172	155	141	130	122	114	109	105	103	101	98	96	92
145	207	187	167	149	136	126	118	110	105	102	99	97	95	93	89
150	205	183	162	144	131	122	114	106	102	98	96	94	91	90	86
155	201	178	157	140	127	118	111	103	98	95	93	91	88	87	84
160	198	174	152	135	123	114	107	100	95	92	90	88	86	84	81
165	194	170	147	131	119	111	104	97	92	89	87	86	83	82	78
170	191	165	143	127	116	107	101	94	90	87	85	83	81	79	78
175	187	161	139	124	113	104	98	91	87	84	82	81	78	77	74
180	184	157	135	120	109	101	95	89	85	82	80	78	76	75	72
185	180	153	131	117	106	99	93	86	82	80	78	76	74	73	70
190	177	149	128	114	104	96	90	84	80	77	76	74	72	71	68
195	173	145	125	111	101	94	88	82	78	76	74	72	70	69	66
200	170	141	122	108	98	91	86	80	76	74	72	71	69	67	65
205	166	138	119	106	96	89	84	78	74	72	70	69	67	66	63
210	163	134	116	103	94	87	82	76	73	70	68	67	65	64	62
215	159	131	113	101	92	85	80	74	71	68	67	66	64	63	60
220	156	128	111	98	90	83	78	73	69	67	65	64	62	61	59
225	152	125	108	96	88	81	76	71	68	65	64	63	61	60	58
230	149	123	106	94	86	79	74	69	66	64	62	61	60	59	56
235	146	120	103	92	84	78	73	68	65	63	61	60	58	57	55
240	143	118	101	90	82	76	71	67	63	61	60	59	57	56	54
245	140	115	99	88	80	74	70	65	62	60	59	58	56	55	53
250	137	113	97	87	79	73	69	64	61	59	57	56	55	54	52

Note : For other steel grades not covered in Table 8.5, refer to Appendix 8.3.

Table 8.5e - Shear buckling strength q_w (N/mm²) of a web (for $t \leq 16$ mm)

5) Grade S460 steel, web thickness ≤ 16 mm – design strength $p_y = 460$ N/mm ²															
d/t	Stiffener spacing ratio a/d														
	0.4	0.5	0.6	0.7	0.8	0.9	1.0	1.2	1.4	1.6	1.8	2.0	2.5	3.0	∞
55	276	276	276	276	276	276	276	276	276	275	272	269	265	263	256
60	276	276	276	276	276	276	276	275	268	263	259	256	252	249	242
65	276	276	276	276	276	276	273	263	256	250	246	243	238	235	228
70	276	276	276	276	276	272	262	251	244	238	233	230	225	222	214
75	276	276	276	276	273	261	252	240	231	225	221	217	211	208	199
80	276	276	276	276	263	251	241	228	219	213	208	204	198	195	187
85	276	276	276	268	254	241	230	217	207	200	195	192	186	183	176
90	276	276	276	260	245	231	219	205	195	189	184	181	176	173	166
95	276	276	269	251	235	221	208	194	185	179	175	172	167	164	157
100	276	276	261	243	226	211	198	184	176	170	166	163	158	156	150
105	276	276	254	234	216	201	188	176	167	162	158	155	151	148	142
110	276	269	246	226	207	191	180	168	160	155	151	148	144	141	136
115	276	263	239	217	198	183	172	160	153	148	144	142	138	135	130
120	276	256	231	208	189	176	165	154	147	142	138	136	132	130	125
125	276	250	224	200	182	169	158	148	141	136	133	130	127	124	120
130	273	243	216	192	175	162	152	142	135	131	128	125	122	120	115
135	268	237	208	185	168	156	147	137	130	126	123	121	117	115	111
140	262	230	201	178	162	150	141	132	126	121	119	116	113	111	107
145	257	224	194	172	157	145	136	127	121	117	114	112	109	107	103
150	252	217	187	167	152	140	132	123	117	113	111	109	105	104	100
155	246	210	181	161	147	136	128	119	113	110	107	105	102	100	96
160	241	204	176	156	142	132	124	115	110	106	104	102	99	97	93
165	235	197	170	151	138	128	120	112	107	103	101	99	96	94	91
170	230	192	165	147	134	124	116	108	103	100	98	96	93	92	88
175	225	186	160	143	130	120	113	105	100	97	95	93	90	89	85
180	219	181	156	139	126	117	110	102	98	94	92	91	88	86	83
185	214	176	152	135	123	114	107	100	95	92	90	88	86	84	81
190	208	172	148	131	120	111	104	97	93	89	87	86	83	82	79
195	203	167	144	128	117	108	101	95	90	87	85	84	81	80	77
200	198	163	140	125	114	105	99	92	88	85	83	81	79	78	75
205	193	159	137	122	111	103	96	90	86	83	81	79	77	76	73
210	188	155	134	119	108	100	94	88	84	81	79	78	75	74	71
215	184	152	131	116	106	98	92	86	82	79	77	76	74	72	70
220	180	148	128	114	103	96	90	84	80	77	75	74	72	71	68
225	176	145	125	111	101	94	88	82	78	76	74	72	70	69	66
230	172	142	122	109	99	92	86	80	76	74	72	71	69	68	65
235	168	139	120	106	97	90	84	78	75	72	71	69	67	66	64
240	165	136	117	104	95	88	82	77	73	71	69	68	66	65	62
245	161	133	115	102	93	86	81	75	72	69	68	67	65	64	61
250	158	130	112	100	91	84	79	74	70	68	66	65	63	62	60

Note : For other steel grades not covered in Table 8.5, refer to Appendix 8.3.

Table 8.5f - Shear buckling strength q_w (N/mm²) of a web (for 16mm < $t \leq 40$ mm)

6) Grade S460 steel, web thickness >16mm ≤ 40mm – design strength $p_y = 440$ N/mm ²															
d/t	Stiffener spacing ratio a/d														
	0.4	0.5	0.6	0.7	0.8	0.9	1.0	1.2	1.4	1.6	1.8	2.0	2.5	3.0	∞
55	264	264	264	264	264	264	264	264	264	264	263	261	257	254	249
60	264	264	264	264	264	264	264	264	259	255	251	248	244	242	235
65	264	264	264	264	264	264	264	255	248	243	239	236	231	229	222
70	264	264	264	264	264	263	254	244	237	231	227	224	219	216	209
75	264	264	264	264	264	253	244	233	225	219	215	212	206	203	195
80	264	264	264	264	255	244	234	222	214	208	203	199	194	190	183
85	264	264	264	260	246	234	224	211	202	196	191	187	182	179	172
90	264	264	264	252	237	225	214	201	191	185	180	177	172	169	162
95	264	264	260	244	229	215	204	190	181	175	171	168	163	160	154
100	264	264	253	236	220	206	194	180	172	166	162	159	155	152	146
105	264	264	246	228	211	196	184	172	164	158	155	152	147	145	139
110	264	261	239	220	202	187	176	164	156	151	148	145	141	138	133
115	264	255	232	212	194	179	168	157	150	145	141	139	135	132	127
120	264	248	225	204	185	172	161	150	143	139	135	133	129	127	122
125	264	242	218	196	178	165	155	144	138	133	130	127	124	122	117
130	264	236	211	188	171	158	149	139	132	128	125	123	119	117	112
135	259	230	204	181	165	153	143	134	127	123	120	118	115	113	108
140	254	224	196	174	159	147	138	129	123	119	116	114	111	109	104
145	249	218	189	168	153	142	133	124	119	115	112	110	107	105	101
150	244	212	183	163	148	137	129	120	115	111	108	106	103	101	97
155	239	206	177	158	143	133	125	116	111	107	105	103	100	98	94
160	234	199	172	153	139	129	121	113	107	104	101	100	97	95	91
165	229	193	166	148	135	125	117	109	104	101	98	97	94	92	89
170	224	187	162	144	131	121	114	106	101	98	95	94	91	90	86
175	219	182	157	140	127	118	111	103	98	95	93	91	88	87	84
180	214	177	153	136	124	114	107	100	96	92	90	89	86	85	81
185	209	172	148	132	120	111	105	97	93	90	88	86	84	82	79
190	204	168	145	129	117	108	102	95	90	88	85	84	81	80	77
195	199	163	141	125	114	106	99	92	88	85	83	82	79	78	75
200	194	159	137	122	111	103	97	90	86	83	81	80	77	76	73
205	189	155	134	119	108	100	94	88	84	81	79	78	75	74	71
210	184	152	131	116	106	98	92	86	82	79	77	76	74	72	70
215	180	148	128	114	103	96	90	84	80	77	75	74	72	71	68
220	176	145	125	111	101	94	88	82	78	76	74	72	70	69	66
225	172	142	122	109	99	92	86	80	76	74	72	71	69	68	65
230	168	139	119	106	97	90	84	78	75	72	71	69	67	66	64
235	165	136	117	104	95	88	82	77	73	71	69	68	66	65	62
240	161	133	114	102	93	86	81	75	72	69	68	66	64	63	61
245	158	130	112	100	91	84	79	74	70	68	66	65	63	62	60
250	155	127	110	98	89	82	77	72	69	67	65	64	62	61	58

Note : For other steel grades not covered in Table 8.5, refer to Appendix 8.3.

Table 8.5g - Shear buckling strength q_w (N/mm²) of a web (for $t \leq 50$ mm)

7) Grade S550 steel, web thickness ≤ 50 mm – design strength $p_y = 550$ N/mm ²															
d/t	Stiffener spacing ratio a/d														
	0.4	0.5	0.6	0.7	0.8	0.9	1.0	1.2	1.4	1.6	1.8	2.0	2.5	3.0	∞
55	330	330	330	330	330	330	330	328	320	314	309	306	300	297	289
60	330	330	330	330	330	330	330	325	313	304	297	293	289	283	279
65	330	330	330	330	330	330	322	311	298	288	281	276	272	265	261
70	330	330	330	330	323	309	297	283	272	265	259	255	248	243	234
75	330	330	330	327	310	296	283	267	256	248	242	238	231	227	218
80	330	330	330	316	298	282	269	252	240	232	227	223	216	213	204
85	330	330	325	304	286	269	255	237	226	219	213	210	204	200	192
90	330	330	316	293	274	256	240	224	214	207	202	198	192	189	182
95	330	330	306	282	261	243	228	212	202	196	191	188	182	179	172
100	330	323	296	271	249	230	216	202	192	186	181	178	173	170	163
105	330	315	286	260	237	219	206	192	183	177	173	170	165	162	156
110	330	306	276	249	226	209	197	183	175	169	165	162	157	155	149
115	330	297	266	238	216	200	188	175	167	162	158	155	150	148	142
120	325	289	256	228	207	192	180	168	160	155	151	148	144	142	136
125	318	280	246	219	199	184	173	161	154	149	145	143	138	136	131
130	311	272	236	210	191	177	166	155	148	143	140	137	133	131	126
135	304	263	227	202	184	171	160	149	142	138	134	132	128	126	121
140	297	255	219	195	178	165	154	144	137	133	130	127	124	122	117
145	290	246	212	188	171	159	149	139	133	128	125	123	119	117	113
150	283	238	205	182	166	154	144	134	128	124	121	119	115	113	109
155	276	230	198	176	160	149	140	130	124	120	117	115	112	110	105
160	269	223	192	171	155	144	135	126	120	116	113	111	108	106	102
165	262	216	186	166	151	140	131	122	117	113	110	108	105	103	99
170	255	210	181	161	146	135	127	119	113	109	107	105	102	100	96
175	248	204	175	156	142	132	124	115	110	106	104	102	99	97	93
180	240	198	171	152	138	128	120	112	107	103	101	99	96	95	91
185	234	193	166	148	134	124	117	109	104	100	98	96	94	92	88
190	228	188	162	144	131	121	114	106	101	98	95	94	91	90	86
195	222	183	157	140	127	118	111	103	99	95	93	91	89	87	84
200	216	178	154	137	124	115	108	101	96	93	91	89	87	85	82
205	211	174	150	133	121	112	106	98	94	91	89	87	84	83	80
210	206	170	146	130	118	110	103	96	92	89	86	85	82	81	78
215	201	166	143	127	116	107	101	94	89	86	84	83	80	79	76
220	197	162	140	124	113	105	98	92	87	85	82	81	79	77	74
225	192	158	136	121	110	102	96	90	85	83	81	79	77	76	73
230	188	155	134	119	108	100	94	88	84	81	79	77	75	74	71
235	184	152	131	116	106	98	92	86	82	79	77	76	74	72	70
240	180	148	128	114	104	96	90	84	80	77	76	74	72	71	68
245	177	145	125	111	101	94	88	82	78	76	74	73	71	69	67
250	173	143	123	109	99	92	87	81	77	74	73	71	69	68	65

Note : For other steel grades not covered in Table 8.5, refer to Appendix 8.3.

Table 8.5h - Shear buckling strength q_w (N/mm²) of a web (for 50mm < $t \leq 100$ mm)

8) Grade S550 steel, web thickness >50mm ≤ 100mm – design strength $p_y = 530$ N/mm ²															
d/t	Stiffener spacing ratio a/d														
	0.4	0.5	0.6	0.7	0.8	0.9	1.0	1.2	1.4	1.6	1.8	2.0	2.5	3.0	∞
55	318	318	318	318	318	318	318	318	311	306	301	298	293	290	282
60	318	318	318	318	318	318	316	305	296	290	286	282	276	273	265
65	318	318	318	318	318	313	303	290	281	275	270	266	260	256	247
70	318	318	318	318	314	301	290	276	266	259	254	250	243	239	229
75	318	318	318	318	302	288	276	262	251	244	238	233	226	223	214
80	318	318	318	307	291	276	263	247	236	228	223	219	212	209	201
85	318	318	317	297	279	263	250	233	222	215	210	206	200	197	189
90	318	318	307	286	267	251	236	220	210	203	198	194	189	186	178
95	318	318	298	276	256	238	223	208	199	192	187	184	179	176	169
100	318	314	288	265	244	226	212	198	189	182	178	175	170	167	160
105	318	306	279	255	233	215	202	188	180	174	170	167	162	159	153
110	318	298	270	244	222	206	193	180	172	166	162	159	154	152	146
115	318	290	260	233	212	197	185	172	164	159	155	152	148	145	140
120	316	282	251	223	203	188	177	165	157	152	148	146	142	139	134
125	310	274	241	214	195	181	170	158	151	146	142	140	136	134	128
130	303	266	232	206	188	174	163	152	145	140	137	135	131	128	123
135	296	258	223	199	181	167	157	147	140	135	132	130	126	124	119
140	290	250	215	192	174	161	152	141	135	130	127	125	121	119	115
145	283	242	208	185	168	156	146	136	130	126	123	121	117	115	111
150	276	233	201	179	163	151	142	132	126	122	119	117	113	111	107
155	270	226	194	173	157	146	137	128	122	118	115	113	110	108	104
160	263	219	188	168	153	141	133	124	118	114	111	109	106	104	100
165	256	212	183	162	148	137	129	120	114	111	108	106	103	101	97
170	250	206	177	158	144	133	125	116	111	107	105	103	100	98	94
175	243	200	172	153	139	129	121	113	108	104	102	100	97	95	92
180	236	194	167	149	136	126	118	110	105	101	99	97	94	93	89
185	230	189	163	145	132	122	115	107	102	99	96	95	92	90	87
190	223	184	159	141	128	119	112	104	99	96	94	92	89	88	84
195	218	179	155	137	125	116	109	101	97	94	91	90	87	86	82
200	212	175	151	134	122	113	106	99	94	91	89	87	85	84	80
205	207	171	147	131	119	110	104	97	92	89	87	85	83	81	78
210	202	167	144	128	116	108	101	94	90	87	85	83	81	80	76
215	197	163	140	125	114	105	99	92	88	85	83	81	79	78	75
220	193	159	137	122	111	103	97	90	86	83	81	79	77	76	73
225	189	155	134	119	108	100	94	88	84	81	79	78	75	74	71
230	185	152	131	117	106	98	92	86	82	79	77	76	74	73	70
235	181	149	128	114	104	96	90	84	80	78	76	74	72	71	68
240	177	146	126	112	102	94	88	82	79	76	74	73	71	70	67
245	173	143	123	109	100	92	87	81	77	74	73	71	69	68	66
250	170	140	121	107	98	90	85	79	75	73	71	70	68	67	64

Note : For other steel grades not covered in Table 8.5, refer to Appendix 8.3.

Table 8.5i - Shear buckling strength q_w (N/mm²) of a web (for $t \leq 50$ mm)

9) Grade S690 steel, web thickness ≤ 50mm – design strength $p_y = 690$N/mm²															
d/t	Stiffener spacing ratio a/d														
	0.4	0.5	0.6	0.7	0.8	0.9	1.0	1.2	1.4	1.6	1.8	2.0	2.5	3.0	∞
55	414	414	414	414	414	414	402	386	375	367	360	356	348	343	332
60	414	414	414	414	413	397	382	365	353	344	337	331	323	318	306
65	414	414	414	414	396	378	363	344	330	320	313	307	298	293	282
70	414	414	414	400	379	360	343	323	308	297	290	285	277	272	262
75	414	414	411	385	362	341	323	301	287	278	271	266	258	254	244
80	414	414	397	369	344	322	303	282	269	260	254	249	242	238	229
85	414	414	383	353	327	304	285	266	253	245	239	235	228	224	215
90	414	404	369	338	310	287	269	251	239	231	226	222	215	212	203
95	414	392	355	322	293	272	255	238	227	219	214	210	204	201	193
100	414	380	341	306	278	258	242	226	215	208	203	200	194	191	183
105	412	368	327	291	265	246	231	215	205	198	194	190	185	182	174
110	402	356	313	278	253	235	220	205	196	189	185	181	176	173	166
115	392	344	299	266	242	224	211	196	187	181	177	174	169	166	159
120	382	331	287	255	232	215	202	188	179	174	169	166	161	159	153
125	372	319	275	245	223	206	194	181	172	167	163	160	155	152	146
130	363	307	265	235	214	198	186	174	166	160	156	154	149	147	141
135	353	296	255	227	206	191	179	167	160	154	151	148	144	141	136
140	343	285	246	219	199	184	173	161	154	149	145	143	138	136	131
145	333	275	237	211	192	178	167	156	149	144	140	138	134	131	126
150	323	266	229	204	186	172	161	151	144	139	135	133	129	127	122
155	313	257	222	197	180	166	156	146	139	134	131	129	125	123	118
160	303	249	215	191	174	161	151	141	135	130	127	125	121	119	114
165	294	242	208	185	169	156	147	137	131	126	123	121	117	116	111
170	285	235	202	180	164	152	142	133	127	122	120	117	114	112	108
175	277	228	197	175	159	147	138	129	123	119	116	114	111	109	105
180	269	222	191	170	155	143	135	125	120	116	113	111	108	106	102
185	262	216	186	165	151	139	131	122	116	113	110	108	105	103	99
190	255	210	181	161	147	136	127	119	113	110	107	105	102	100	96
195	248	205	176	157	143	132	124	116	110	107	104	102	99	98	94
200	242	200	172	153	139	129	121	113	108	104	102	100	97	95	92
205	236	195	168	149	136	126	118	110	105	102	99	97	95	93	89
210	231	190	164	146	133	123	115	108	103	99	97	95	92	91	87
215	225	186	160	142	130	120	113	105	100	97	95	93	90	89	85
220	220	181	156	139	127	117	110	103	98	95	92	91	88	87	83
225	215	177	153	136	124	115	108	100	96	93	90	89	86	85	81
230	211	174	150	133	121	112	105	98	94	91	88	87	84	83	80
235	206	170	146	130	118	110	103	96	92	89	86	85	82	81	78
240	202	166	143	127	116	107	101	94	90	87	85	83	81	79	76
245	198	163	140	125	114	105	99	92	88	85	83	81	79	78	75
250	194	160	138	122	111	103	97	90	86	83	81	80	78	76	73

Note : For other steel grades not covered in Table 8.5, refer to Appendix 8.3.

Table 8.5j - Shear buckling strength q_w (N/mm²) of a web (for 50mm < $t \leq 100$ mm)

10) Grade S690 steel, web thickness >50mm ≤ 100mm – design strength $p_y = 650$ N/mm ²															
d/t	Stiffener spacing ratio a/d														
	0.4	0.5	0.6	0.7	0.8	0.9	1.0	1.2	1.4	1.6	1.8	2.0	2.5	3.0	∞
55	390	390	390	390	390	390	385	370	360	352	347	342	335	331	321
60	390	390	390	390	390	380	367	351	340	331	325	320	312	308	297
65	390	390	390	390	379	363	349	332	319	310	303	298	290	285	273
70	390	390	390	383	364	346	331	312	299	289	282	277	269	264	254
75	390	390	390	369	348	329	312	293	279	269	263	258	251	247	237
80	390	390	380	355	332	312	294	274	261	253	247	242	235	231	222
85	390	390	367	340	316	295	277	258	246	238	232	228	221	218	209
90	390	386	355	326	301	278	261	244	232	225	219	215	209	206	197
95	390	375	342	312	285	264	247	231	220	213	208	204	198	195	187
100	390	364	329	297	270	250	235	219	209	202	197	194	188	185	178
105	390	353	316	283	257	238	224	209	199	192	188	184	179	176	169
110	385	342	303	270	246	228	214	199	190	184	179	176	171	168	162
115	376	331	291	258	235	218	204	191	182	176	172	168	164	161	155
120	367	320	278	247	225	209	196	183	174	168	164	161	157	154	148
125	358	309	267	238	216	200	188	175	167	162	158	155	150	148	142
130	349	298	257	228	208	193	181	169	161	155	152	149	145	142	137
135	340	287	247	220	200	185	174	162	155	150	146	143	139	137	132
140	331	277	238	212	193	179	168	157	149	144	141	138	134	132	127
145	321	267	230	205	186	173	162	151	144	139	136	134	130	128	123
150	312	258	223	198	180	167	157	146	139	135	131	129	125	123	118
155	303	250	215	192	174	162	152	141	135	130	127	125	121	119	115
160	294	242	209	186	169	156	147	137	131	126	123	121	118	116	111
165	285	235	202	180	164	152	142	133	127	122	120	117	114	112	108
170	277	228	196	175	159	147	138	129	123	119	116	114	111	109	105
175	269	221	191	170	154	143	134	125	119	115	113	111	107	106	102
180	261	215	185	165	150	139	131	122	116	112	110	108	104	103	99
185	254	209	180	160	146	135	127	118	113	109	107	105	102	100	96
190	247	204	176	156	142	132	124	115	110	106	104	102	99	97	94
195	241	199	171	152	139	128	121	112	107	104	101	99	96	95	91
200	235	194	167	148	135	125	118	110	104	101	99	97	94	92	89
205	229	189	163	145	132	122	115	107	102	99	96	94	92	90	87
210	224	184	159	141	129	119	112	104	100	96	94	92	90	88	85
215	219	180	155	138	126	116	109	102	97	94	92	90	87	86	83
220	214	176	152	135	123	114	107	100	95	92	90	88	85	84	81
225	209	172	148	132	120	111	104	97	93	90	88	86	84	82	79
230	204	168	145	129	118	109	102	95	91	88	86	84	82	80	77
235	200	165	142	126	115	107	100	93	89	86	84	82	80	79	76
240	196	161	139	124	113	104	98	91	87	84	82	81	78	77	74
245	192	158	136	121	110	102	96	89	85	82	81	79	77	76	73
250	188	155	134	119	108	100	94	88	84	81	79	77	75	74	71

Note : For other steel grades not covered in Table 8.5, refer to Appendix 8.3.

Table 8.5k - Shear buckling strength q_w (N/mm²) of a web (for $t \leq 16$ mm)

11) Grade Q235 steel, web thickness ≤ 16 mm – design strength $p_y = 215$ N/mm ²															
d/t	Stiffener spacing ratio a/d														
	0.4	0.5	0.6	0.7	0.8	0.9	1.0	1.2	1.4	1.6	1.8	2.0	2.5	3.0	∞
55	129	129	129	129	129	129	129	129	129	129	129	129	129	129	129
60	129	129	129	129	129	129	129	129	129	129	129	129	129	129	129
65	129	129	129	129	129	129	129	129	129	129	129	129	129	129	129
70	129	129	129	129	129	129	129	129	129	129	129	129	129	129	129
75	129	129	129	129	129	129	129	129	129	129	129	129	128	127	124
80	129	129	129	129	129	129	129	129	129	129	127	126	124	123	120
85	129	129	129	129	129	129	129	129	127	125	123	122	119	118	115
90	129	129	129	129	129	129	129	126	123	121	119	117	115	114	111
95	129	129	129	129	129	129	127	122	119	117	115	113	111	110	106
100	129	129	129	129	129	128	124	119	115	113	111	109	107	105	102
105	129	129	129	129	129	125	120	115	111	109	106	105	102	101	97
110	129	129	129	129	127	122	117	111	107	105	102	101	98	96	92
115	129	129	129	129	124	118	113	108	104	101	98	97	94	92	88
120	129	129	129	127	121	115	110	104	100	97	94	92	90	88	85
125	129	129	129	124	118	112	107	100	96	92	90	89	86	85	81
130	129	129	129	122	115	109	103	97	92	89	87	85	83	81	78
135	129	129	127	119	112	105	100	93	89	86	84	82	80	78	75
140	129	129	125	116	109	102	96	90	85	83	81	79	77	75	73
145	129	129	122	114	106	99	93	86	82	80	78	76	74	73	70
150	129	129	120	111	103	96	90	84	80	77	75	74	72	70	68
155	129	128	117	108	100	92	87	81	77	74	73	71	69	68	65
160	129	126	115	105	97	90	84	78	75	72	70	69	67	66	63
165	129	124	113	103	94	87	81	76	72	70	68	67	65	64	61
170	129	122	110	100	91	84	79	74	70	68	66	65	63	62	60
175	129	120	108	97	88	82	77	72	68	66	64	63	61	60	58
180	129	117	105	94	86	80	75	70	66	64	63	61	60	59	56
185	129	115	103	92	84	77	73	68	64	62	61	60	58	57	55
190	127	113	100	89	81	75	71	66	63	61	59	58	56	55	53
195	126	111	98	87	79	73	69	64	61	59	58	57	55	54	52
200	124	109	96	85	77	72	67	63	60	58	56	55	54	53	51
205	122	107	93	83	75	70	65	61	58	56	55	54	52	51	49
210	120	105	91	81	74	68	64	60	57	55	54	53	51	50	48
215	119	103	89	79	72	66	62	58	55	54	52	51	50	49	47
220	117	101	87	77	70	65	61	57	54	52	51	50	49	48	46
225	115	99	85	75	69	64	60	56	53	51	50	49	48	47	45
230	113	97	83	74	67	62	58	54	52	50	49	48	47	46	44
235	112	94	81	72	66	61	57	53	51	49	48	47	46	45	43
240	110	92	79	71	64	60	56	52	50	48	47	46	45	44	42
245	108	90	78	69	63	58	55	51	49	47	46	45	44	43	41
250	107	89	76	68	62	57	54	50	48	46	45	44	43	42	40

Note : For other steel grades not covered in Table 8.5, refer to Appendix 8.3.

Table 8.5I - Shear buckling strength q_w (N/mm²) of a web (for 16mm < $t \leq 40$ mm)

12) Grade Q235 steel, web thickness >16mm ≤ 40mm – design strength $p_y = 205$ N/mm ²															
d/t	Stiffener spacing ratio a/d														
	0.4	0.5	0.6	0.7	0.8	0.9	1.0	1.2	1.4	1.6	1.8	2.0	2.5	3.0	∞
55	123	123	123	123	123	123	123	123	123	123	123	123	123	123	123
60	123	123	123	123	123	123	123	123	123	123	123	123	123	123	123
65	123	123	123	123	123	123	123	123	123	123	123	123	123	123	123
70	123	123	123	123	123	123	123	123	123	123	123	123	123	123	123
75	123	123	123	123	123	123	123	123	123	123	123	123	123	123	120
80	123	123	123	123	123	123	123	123	123	123	123	121	120	118	116
85	123	123	123	123	123	123	123	123	122	120	119	118	116	114	112
90	123	123	123	123	123	123	123	122	119	117	115	114	112	110	107
95	123	123	123	123	123	123	123	118	115	113	111	110	108	106	103
100	123	123	123	123	123	123	120	115	112	109	107	106	104	102	99
105	123	123	123	123	123	120	116	111	108	105	103	102	100	98	95
110	123	123	123	123	122	117	113	108	104	102	100	98	96	94	90
115	123	123	123	123	120	114	110	105	101	98	96	94	91	90	86
120	123	123	123	123	117	111	107	101	97	94	92	90	88	86	83
125	123	123	123	120	114	108	104	98	93	90	88	87	84	83	79
130	123	123	123	118	111	105	100	94	90	87	85	83	81	79	76
135	123	123	123	115	108	102	97	91	86	84	82	80	78	76	73
140	123	123	120	113	106	99	94	87	83	81	79	77	75	74	71
145	123	123	118	110	103	96	91	84	80	78	76	75	72	71	68
150	123	123	116	108	100	93	88	82	78	75	73	72	70	69	66
155	123	123	114	105	97	90	85	79	75	73	71	70	68	67	64
160	123	121	111	102	94	87	82	76	73	70	69	67	66	64	62
165	123	119	109	100	92	85	80	74	71	68	67	65	64	62	60
170	123	118	107	97	89	82	77	72	69	66	65	63	62	61	58
175	123	116	105	95	86	80	75	70	67	64	63	62	60	59	57
180	123	114	102	92	84	78	73	68	65	63	61	60	58	57	55
185	123	112	100	90	82	76	71	66	63	61	59	58	57	56	53
190	123	110	98	87	79	74	69	64	61	59	58	57	55	54	52
195	121	108	96	85	77	72	67	63	60	58	56	55	54	53	51
200	120	106	93	83	75	70	66	61	58	56	55	54	52	51	49
205	118	104	91	81	74	68	64	60	57	55	54	53	51	50	48
210	116	102	89	79	72	66	62	58	55	54	52	51	50	49	47
215	115	100	87	77	70	65	61	57	54	52	51	50	49	48	46
220	113	98	85	75	68	63	60	55	53	51	50	49	48	47	45
225	112	96	83	74	67	62	58	54	52	50	49	48	46	46	44
230	110	94	81	72	65	61	57	53	51	49	48	47	45	45	43
235	108	92	79	70	64	59	56	52	49	48	47	46	44	44	42
240	107	90	78	69	63	58	55	51	48	47	46	45	44	43	41
245	105	88	76	68	61	57	53	50	47	46	45	44	43	42	40
250	104	87	74	66	60	56	52	49	46	45	44	43	42	41	39

Note : For other steel grades not covered in Table 8.5, refer to Appendix 8.3.

Table 8.5m - Shear buckling strength q_w (N/mm²) of a web (for $t \leq 16$ mm)

13) Grade Q345/Q355 steel, web thickness ≤ 16 mm – design strength $p_y = 305$ N/mm ²															
d/t	Stiffener spacing ratio a/d														
	0.4	0.5	0.6	0.7	0.8	0.9	1.0	1.2	1.4	1.6	1.8	2.0	2.5	3.0	∞
55	183	183	183	183	183	183	183	183	183	183	183	183	183	183	183
60	183	183	183	183	183	183	183	183	183	183	183	183	183	183	183
65	183	183	183	183	183	183	183	183	183	183	183	182	179	178	174
70	183	183	183	183	183	183	183	183	183	182	179	177	175	172	170
75	183	183	183	183	183	183	183	183	180	176	172	170	168	165	163
80	183	183	183	183	183	183	181	174	169	166	163	161	158	156	151
85	183	183	183	183	183	181	175	168	163	159	156	154	150	148	143
90	183	183	183	183	183	176	169	162	156	152	149	147	143	141	135
95	183	183	183	183	178	170	163	155	150	145	142	140	136	134	128
100	183	183	183	182	173	165	158	149	143	139	135	133	129	127	122
105	183	183	183	177	168	159	152	143	137	132	129	126	123	121	116
110	183	183	183	173	163	154	146	137	130	126	123	121	117	115	111
115	183	183	180	168	158	148	140	131	124	120	117	115	112	110	106
120	183	183	176	163	153	143	134	125	119	115	113	111	107	106	101
125	183	183	172	159	147	137	129	120	115	111	108	106	103	101	97
130	183	182	167	154	142	132	124	115	110	106	104	102	99	97	94
135	183	179	163	150	137	127	119	111	106	103	100	98	95	94	90
140	183	175	159	145	132	123	115	107	102	99	97	95	92	91	87
145	183	172	155	140	128	118	111	104	99	95	93	91	89	87	84
150	183	168	151	136	123	114	107	100	95	92	90	88	86	84	81
155	183	165	147	131	119	111	104	97	92	89	87	86	83	82	79
160	181	161	143	127	116	107	101	94	89	87	84	83	81	79	76
165	178	157	139	123	112	104	98	91	87	84	82	80	78	77	74
170	175	154	135	120	109	101	95	88	84	81	79	78	76	75	72
175	172	150	131	116	106	98	92	86	82	79	77	76	74	72	70
180	169	147	127	113	103	95	89	83	80	77	75	74	72	70	68
185	166	143	124	110	100	93	87	81	77	75	73	72	70	68	66
190	163	140	120	107	97	90	85	79	75	73	71	70	68	67	64
195	161	136	117	104	95	88	83	77	73	71	69	68	66	65	62
200	158	133	114	102	93	86	81	75	72	69	68	66	64	63	61
205	155	129	112	99	90	84	79	73	70	68	66	65	63	62	59
210	152	126	109	97	88	82	77	71	68	66	64	63	61	60	58
215	149	123	106	95	86	80	75	70	67	64	63	62	60	59	57
220	146	121	104	92	84	78	73	68	65	63	61	60	59	58	55
225	143	118	102	90	82	76	72	67	64	62	60	59	57	56	54
230	140	115	99	88	80	75	70	65	62	60	59	58	56	55	53
235	137	113	97	87	79	73	69	64	61	59	57	56	55	54	52
240	134	111	95	85	77	71	67	63	60	58	56	55	54	53	51
245	131	108	93	83	76	70	66	61	58	57	55	54	53	52	50
250	129	106	91	81	74	69	64	60	57	55	54	53	52	51	49

Note : For other steel grades not covered in Table 8.5, refer to Appendix 8.3.

Table 8.5n - Shear buckling strength q_w (N/mm²) of a web (for 16mm < $t \leq 40$ mm)

14) Grade Q345/Q355 steel, web thickness >16mm ≤ 40mm – design strength $p_y = 295$ N/mm ²															
d/t	Stiffener spacing ratio a/d														
	0.4	0.5	0.6	0.7	0.8	0.9	1.0	1.2	1.4	1.6	1.8	2.0	2.5	3.0	∞
55	177	177	177	177	177	177	177	177	177	177	177	177	177	177	177
60	177	177	177	177	177	177	177	177	177	177	177	177	177	177	177
65	177	177	177	177	177	177	177	177	177	177	177	177	175	174	170
70	177	177	177	177	177	177	177	177	177	175	173	171	168	167	163
75	177	177	177	177	177	177	177	176	172	168	166	164	161	160	155
80	177	177	177	177	177	177	176	170	165	162	159	158	154	152	148
85	177	177	177	177	177	177	171	164	159	156	153	151	147	145	141
90	177	177	177	177	177	171	165	158	153	149	146	144	141	138	133
95	177	177	177	177	174	166	160	152	147	143	140	137	134	131	126
100	177	177	177	177	169	161	154	146	140	136	133	131	127	125	120
105	177	177	177	173	164	156	149	140	134	130	127	124	121	119	114
110	177	177	177	169	159	151	143	134	128	124	121	119	115	113	109
115	177	177	175	164	154	145	138	128	122	118	116	113	110	108	104
120	177	177	171	160	149	140	132	123	117	113	111	109	106	104	100
125	177	177	168	155	145	135	127	118	113	109	106	104	101	100	96
130	177	177	164	151	140	130	122	114	108	105	102	100	97	96	92
135	177	174	160	147	135	125	117	109	104	101	98	97	94	92	89
140	177	171	156	142	130	120	113	105	101	97	95	93	91	89	86
145	177	168	152	138	126	116	109	102	97	94	92	90	87	86	83
150	177	164	148	134	121	112	106	98	94	91	89	87	84	83	80
155	177	161	144	129	117	109	102	95	91	88	86	84	82	80	77
160	176	158	140	125	114	105	99	92	88	85	83	82	79	78	75
165	174	154	136	121	110	102	96	89	85	83	81	79	77	76	73
170	171	151	132	118	107	99	93	87	83	80	78	77	75	73	70
175	168	147	129	114	104	96	91	84	80	78	76	75	72	71	68
180	165	144	125	111	101	94	88	82	78	76	74	72	70	69	67
185	163	141	122	108	98	91	86	80	76	74	72	71	68	67	65
190	160	137	118	105	96	89	83	78	74	72	70	69	67	66	63
195	157	134	115	103	93	87	81	76	72	70	68	67	65	64	61
200	154	131	112	100	91	84	79	74	70	68	66	65	63	62	60
205	152	127	110	98	89	82	77	72	69	66	65	64	62	61	58
210	149	124	107	95	87	80	75	70	67	65	63	62	60	59	57
215	146	121	105	93	85	78	74	69	65	63	62	61	59	58	56
220	143	119	102	91	83	77	72	67	64	62	60	59	58	57	54
225	141	116	100	89	81	75	70	66	63	61	59	58	56	55	53
230	138	113	98	87	79	73	69	64	61	59	58	57	55	54	52
235	135	111	96	85	77	72	67	63	60	58	57	56	54	53	51
240	132	109	94	83	76	70	66	62	59	57	55	54	53	52	50
245	129	107	92	82	74	69	65	60	57	56	54	53	52	51	49
250	127	104	90	80	73	67	63	59	56	54	53	52	51	50	48

Note : For other steel grades not covered in Table 8.5, refer to Appendix 8.3.

Table 8.5o - Shear buckling strength q_w (N/mm²) of a web (for $t \leq 16$ mm)

15) Grade Q390 steel, web thickness ≤ 16 mm – design strength $p_y = 345$ N/mm ²															
d/t	Stiffener spacing ratio a/d														
	0.4	0.5	0.6	0.7	0.8	0.9	1.0	1.2	1.4	1.6	1.8	2.0	2.5	3.0	∞
55	207	207	207	207	207	207	207	207	207	207	207	207	207	207	207
60	207	207	207	207	207	207	207	207	207	207	207	207	205	203	199
65	207	207	207	207	207	207	207	207	207	204	201	200	196	194	190
70	207	207	207	207	207	207	207	205	200	196	193	191	187	185	180
75	207	207	207	207	207	207	205	197	192	188	185	183	179	177	171
80	207	207	207	207	207	205	198	190	184	180	176	174	170	168	162
85	207	207	207	207	206	198	191	182	176	172	168	165	161	159	153
90	207	207	207	207	200	192	184	175	168	163	160	157	152	150	144
95	207	207	207	205	194	185	177	167	160	155	151	149	144	142	136
100	207	207	207	199	188	178	170	160	152	147	144	141	137	135	129
105	207	207	206	194	182	172	163	152	145	140	137	134	131	128	123
110	207	207	202	188	176	165	156	145	138	134	131	128	125	123	118
115	207	207	197	182	170	159	149	139	132	128	125	123	119	117	113
120	207	207	192	177	164	152	143	133	127	123	120	118	114	112	108
125	207	204	187	171	158	146	137	128	122	118	115	113	110	108	104
130	207	200	182	166	152	140	132	123	117	113	111	109	105	104	100
135	207	195	177	160	146	135	127	118	113	109	106	105	102	100	96
140	207	191	172	155	141	130	122	114	109	105	103	101	98	96	92
145	207	187	167	149	136	126	118	110	105	102	99	97	95	93	89
150	205	183	162	144	131	122	114	106	102	98	96	94	91	90	86
155	201	178	157	140	127	118	111	103	98	95	93	91	88	87	84
160	198	174	152	135	123	114	107	100	95	92	90	88	86	84	81
165	194	170	147	131	119	111	104	97	92	89	87	86	83	82	78
170	191	165	143	127	116	107	101	94	90	87	85	83	81	79	76
175	187	161	139	124	113	104	98	91	87	84	82	81	78	77	74
180	184	157	135	120	109	101	95	89	85	82	80	78	76	75	72
185	180	153	131	117	106	99	93	86	82	80	78	76	74	73	70
190	177	149	128	114	104	96	90	84	80	77	76	74	72	71	68
195	173	145	125	111	101	94	88	82	78	76	74	72	70	69	66
200	170	141	122	108	98	91	86	80	76	74	72	71	69	67	65
205	166	138	119	106	96	89	84	78	74	72	70	69	67	66	63
210	163	134	116	103	94	87	82	76	73	70	68	67	65	64	62
215	159	131	113	101	92	85	80	74	71	68	67	66	64	63	60
220	156	128	111	98	90	83	78	73	69	67	65	64	62	61	59
225	152	125	108	96	88	81	76	71	68	65	64	63	61	60	58
230	149	123	106	94	86	79	74	69	66	64	62	61	60	59	56
235	146	120	103	92	84	78	73	68	65	63	61	60	58	57	55
240	143	118	101	90	82	76	71	67	63	61	60	59	57	56	54
245	140	115	99	88	80	74	70	65	62	60	59	58	56	55	53
250	137	113	97	87	79	73	69	64	61	59	57	56	55	54	52

Note : For other steel grades not covered in Table 8.5, refer to Appendix 8.3.

Table 8.5p - Shear buckling strength q_w (N/mm²) of a web (for 16mm < $t \leq 40$ mm)

16) Grade Q390 steel, web thickness >16mm ≤ 40mm – design strength $p_y = 330$ N/mm ²															
d/t	Stiffener spacing ratio a/d														
	0.4	0.5	0.6	0.7	0.8	0.9	1.0	1.2	1.4	1.6	1.8	2.0	2.5	3.0	∞
55	198	198	198	198	198	198	198	198	198	198	198	198	198	198	198
60	198	198	198	198	198	198	198	198	198	198	198	198	198	197	193
65	198	198	198	198	198	198	198	198	198	197	195	193	190	188	184
70	198	198	198	198	198	198	198	198	193	190	187	185	182	180	175
75	198	198	198	198	198	198	198	191	186	182	179	177	174	172	167
80	198	198	198	198	198	198	192	184	179	175	172	169	166	163	158
85	198	198	198	198	198	192	185	177	171	167	164	161	157	155	149
90	198	198	198	198	194	186	179	170	164	159	156	153	149	147	141
95	198	198	198	198	188	180	172	163	157	152	148	145	141	139	133
100	198	198	198	193	183	174	166	156	149	144	141	138	134	132	127
105	198	198	198	188	177	167	159	149	142	137	134	131	128	126	121
110	198	198	195	182	171	161	152	142	135	131	128	125	122	120	115
115	198	198	190	177	165	155	146	136	129	125	122	120	117	115	110
120	198	198	186	172	160	149	140	130	124	120	117	115	112	110	106
125	198	197	181	167	154	143	134	125	119	115	112	110	107	105	101
130	198	193	177	162	148	137	129	120	115	111	108	106	103	101	97
135	198	189	172	156	143	132	124	116	110	107	104	102	99	98	94
140	198	185	167	151	138	127	120	112	106	103	100	99	96	94	90
145	198	181	163	146	133	123	116	108	103	99	97	95	92	91	87
150	198	177	158	141	128	119	112	104	99	96	94	92	89	88	84
155	195	173	153	136	124	115	108	101	96	93	91	89	86	85	82
160	192	169	149	132	120	112	105	98	93	90	88	86	84	82	79
165	188	165	144	128	117	108	102	95	90	87	85	84	81	80	77
170	185	161	140	124	113	105	99	92	88	85	83	81	79	78	74
175	182	157	136	121	110	102	96	89	85	82	80	79	77	75	72
180	179	153	132	118	107	99	93	87	83	80	78	77	74	73	70
185	175	149	129	114	104	96	91	84	80	78	76	75	72	71	68
190	172	145	125	111	101	94	88	82	78	76	74	73	71	69	67
195	169	142	122	108	99	91	86	80	76	74	72	71	69	68	65
200	166	138	119	106	96	89	84	78	74	72	70	69	67	66	63
205	162	135	116	103	94	87	82	76	73	70	69	67	65	64	62
210	159	131	113	101	92	85	80	74	71	69	67	66	64	63	60
215	156	128	111	98	90	83	78	73	69	67	65	64	62	61	59
220	152	125	108	96	88	81	76	71	68	65	64	63	61	60	58
225	149	123	106	94	86	79	74	69	66	64	62	61	60	59	56
230	146	120	103	92	84	78	73	68	65	63	61	60	58	57	55
235	143	117	101	90	82	76	71	66	63	61	60	59	57	56	54
240	140	115	99	88	80	74	70	65	62	60	59	58	56	55	53
245	137	113	97	86	79	73	68	64	61	59	57	56	55	54	52
250	134	110	95	85	77	71	67	62	60	58	56	55	54	53	51

Note : For other steel grades not covered in Table 8.5, refer to Appendix 8.3.

Table 8.5q - Shear buckling strength q_w (N/mm²) of a web (for $t \leq 16$ mm)

17) Grade Q420 steel, web thickness ≤ 16 mm – design strength $p_y = 375$ N/mm ²															
d/t	Stiffener spacing ratio a/d														
	0.4	0.5	0.6	0.7	0.8	0.9	1.0	1.2	1.4	1.6	1.8	2.0	2.5	3.0	∞
55	225	225	225	225	225	225	225	225	225	225	225	225	225	225	222
60	225	225	225	225	225	225	225	225	225	225	223	221	218	216	211
65	225	225	225	225	225	225	225	225	221	217	214	212	208	206	201
70	225	225	225	225	225	225	225	218	212	208	205	202	198	196	190
75	225	225	225	225	225	225	218	209	203	198	195	192	188	186	180
80	225	225	225	225	225	218	210	201	194	189	186	183	178	176	169
85	225	225	225	225	220	210	202	192	185	180	176	173	168	166	159
90	225	225	225	224	213	203	194	184	176	171	167	164	159	156	150
95	225	225	225	218	206	195	186	175	167	162	158	155	150	148	142
100	225	225	225	211	199	188	178	167	159	154	150	147	143	141	135
105	225	225	220	205	192	180	170	159	151	146	143	140	136	134	129
110	225	225	214	199	185	173	162	151	144	140	136	134	130	128	123
115	225	225	208	192	178	166	155	145	138	133	130	128	124	122	117
120	225	221	203	186	171	158	149	139	132	128	125	123	119	117	113
125	225	217	197	180	164	152	143	133	127	123	120	118	114	112	108
130	225	212	192	174	158	146	137	128	122	118	115	113	110	108	104
135	225	207	186	167	152	141	132	123	118	114	111	109	106	104	100
140	225	202	180	161	147	136	128	119	113	110	107	105	102	100	96
145	222	197	175	156	142	131	123	115	109	106	103	101	99	97	93
150	218	192	169	150	137	127	119	111	106	102	100	98	95	94	90
155	214	188	164	146	132	123	115	107	102	99	97	95	92	91	87
160	210	183	158	141	128	119	112	104	99	96	94	92	89	88	84
165	206	178	154	137	124	115	108	101	96	93	91	89	87	85	82
170	202	173	149	133	121	112	105	98	93	90	88	87	84	83	79
175	198	168	145	129	117	109	102	95	91	88	86	84	82	80	77
180	194	164	141	125	114	106	99	92	88	85	83	82	79	78	75
185	190	159	137	122	111	103	97	90	86	83	81	80	77	76	73
190	186	155	133	119	108	100	94	88	84	81	79	77	75	74	71
195	182	151	130	116	105	98	92	85	81	79	77	75	73	72	69
200	178	147	127	113	103	95	89	83	79	77	75	74	71	70	68
205	174	144	124	110	100	93	87	81	77	75	73	72	70	69	66
210	170	140	121	107	98	91	85	79	76	73	71	70	68	67	64
215	166	137	118	105	95	88	83	77	74	71	70	68	66	65	63
220	162	134	115	103	93	86	81	76	72	70	68	67	65	64	61
225	159	131	113	100	91	85	79	74	71	68	67	65	63	62	60
230	155	128	110	98	89	83	78	72	69	67	65	64	62	61	59
235	152	125	108	96	87	81	76	71	68	65	64	63	61	60	57
240	149	123	106	94	86	79	74	69	66	64	62	61	60	59	56
245	146	120	103	92	84	78	73	68	65	63	61	60	58	57	55
250	143	118	101	90	82	76	71	67	63	61	60	59	57	56	54

Note : For other steel grades not covered in Table 8.5, refer to Appendix 8.3.

Table 8.5r - Shear buckling strength q_w (N/mm²) of a web (for 16mm < $t \leq 40$ mm)

18) Grade Q420 steel, web thickness >16mm ≤ 40mm – design strength $p_y = 355$N/mm²															
d/t	Stiffener spacing ratio a/d														
	0.4	0.5	0.6	0.7	0.8	0.9	1.0	1.2	1.4	1.6	1.8	2.0	2.5	3.0	∞
55	213	213	213	213	213	213	213	213	213	213	213	213	213	213	213
60	213	213	213	213	213	213	213	213	213	213	213	213	209	208	203
65	213	213	213	213	213	213	213	213	212	208	206	204	200	198	193
70	213	213	213	213	213	213	213	209	204	200	197	195	191	189	184
75	213	213	213	213	213	213	209	201	196	191	188	186	182	180	174
80	213	213	213	213	213	209	202	194	187	183	180	177	173	170	164
85	213	213	213	213	211	202	195	186	179	174	171	168	164	161	155
90	213	213	213	213	205	195	187	178	171	166	162	159	155	152	146
95	213	213	213	209	198	189	180	170	163	157	153	151	146	144	138
100	213	213	213	203	192	182	173	162	155	149	146	143	139	137	131
105	213	213	211	197	185	175	165	154	147	142	139	136	132	130	125
110	213	213	206	192	179	168	158	147	140	136	133	130	126	124	119
115	213	213	201	186	173	161	151	141	134	130	127	124	121	119	114
120	213	213	195	180	166	154	145	135	129	124	121	119	116	114	109
125	213	208	190	174	160	148	139	130	124	119	117	115	111	109	105
130	213	204	185	169	154	142	134	125	119	115	112	110	107	105	101
135	213	199	180	163	148	137	129	120	114	111	108	106	103	101	97
140	213	195	175	157	143	132	124	116	110	107	104	102	99	98	94
145	213	190	170	151	138	128	120	112	107	103	101	99	96	94	91
150	209	186	165	146	133	123	116	108	103	100	97	95	93	91	88
155	206	181	159	142	129	119	112	105	100	96	94	92	90	88	85
160	202	177	154	137	125	116	109	101	97	93	91	89	87	85	82
165	198	173	150	133	121	112	105	98	94	91	88	87	84	83	80
170	195	168	145	129	117	109	102	95	91	88	86	84	82	80	77
175	191	164	141	125	114	106	99	93	88	85	83	82	79	78	75
180	187	159	137	122	111	103	97	90	86	83	81	80	77	76	73
185	184	155	133	119	108	100	94	88	83	81	79	77	75	74	71
190	180	151	130	115	105	97	91	85	81	79	77	75	73	72	69
195	176	147	127	113	102	95	89	83	79	77	75	73	71	70	67
200	173	143	123	110	100	93	87	81	77	75	73	72	70	68	66
205	169	140	120	107	97	90	85	79	75	73	71	70	68	67	64
210	165	136	117	104	95	88	83	77	74	71	69	68	66	65	63
215	162	133	115	102	93	86	81	75	72	69	68	67	65	64	61
220	158	130	112	100	91	84	79	74	70	68	66	65	63	62	60
225	155	127	110	98	89	82	77	72	69	66	65	64	62	61	58
230	151	124	107	95	87	80	76	70	67	65	63	62	60	59	57
235	148	122	105	93	85	79	74	69	66	64	62	61	59	58	56
240	145	119	103	91	83	77	72	67	64	62	61	60	58	57	55
245	142	117	101	90	82	76	71	66	63	61	59	58	57	56	54
250	139	115	99	88	80	74	70	65	62	60	58	57	56	55	53

Note : For other steel grades not covered in Table 8.5, refer to Appendix 8.3.

Table 8.5s - Shear buckling strength q_w (N/mm²) of a web (for $t \leq 16$ mm)

19) Grade Q460 steel, web thickness ≤ 16 mm – design strength $p_y = 410$ N/mm ²															
d/t	Stiffener spacing ratio a/d														
	0.4	0.5	0.6	0.7	0.8	0.9	1.0	1.2	1.4	1.6	1.8	2.0	2.5	3.0	∞
55	246	246	246	246	246	246	246	246	246	246	246	246	244	242	236
60	246	246	246	246	246	246	246	246	246	242	239	236	232	230	224
65	246	246	246	246	246	246	246	242	236	231	228	225	221	219	212
70	246	246	246	246	246	246	241	232	226	221	217	214	210	207	200
75	246	246	246	246	246	241	232	222	215	210	206	203	198	195	188
80	246	246	246	246	242	232	223	213	205	200	195	192	187	184	176
85	246	246	246	246	234	224	214	203	195	189	185	181	176	173	166
90	246	246	246	239	226	215	205	193	185	178	174	171	166	163	157
95	246	246	246	232	218	207	196	184	175	169	165	162	157	155	149
100	246	246	241	225	211	198	187	174	166	161	157	154	149	147	141
105	246	246	234	218	203	190	178	166	158	153	149	146	142	140	134
110	246	246	228	210	195	181	170	158	151	146	142	140	136	134	128
115	246	242	221	203	187	173	162	151	144	140	136	134	130	128	123
120	246	236	215	196	179	166	156	145	138	134	131	128	124	122	118
125	246	231	209	189	172	159	149	139	133	128	125	123	120	118	113
130	246	225	202	182	165	153	144	134	128	123	120	118	115	113	109
135	246	220	196	175	159	147	138	129	123	119	116	114	111	109	105
140	241	214	190	168	153	142	133	124	119	115	112	110	107	105	101
145	237	209	183	163	148	137	129	120	114	111	108	106	103	101	97
150	232	203	177	157	143	133	124	116	111	107	104	103	100	98	94
155	228	198	171	152	138	128	120	112	107	104	101	99	96	95	91
160	223	192	166	147	134	124	117	109	104	100	98	96	93	92	88
165	219	187	161	143	130	121	113	106	101	97	95	93	91	89	86
170	214	181	156	139	126	117	110	102	98	94	92	90	88	86	83
175	210	176	152	135	123	114	107	99	95	92	90	88	85	84	81
180	205	171	147	131	119	110	104	97	92	89	87	85	83	82	78
185	201	166	143	127	116	107	101	94	90	87	85	83	81	79	76
190	196	162	140	124	113	105	98	92	87	84	82	81	79	77	74
195	192	158	136	121	110	102	96	89	85	82	80	79	77	75	72
200	187	154	133	118	107	99	93	87	83	80	78	77	75	73	71
205	182	150	129	115	105	97	91	85	81	78	76	75	73	72	69
210	178	146	126	112	102	95	89	83	79	76	75	73	71	70	67
215	174	143	123	110	100	92	87	81	77	75	73	72	69	68	66
220	170	140	121	107	98	90	85	79	75	73	71	70	68	67	64
225	166	137	118	105	95	88	83	77	74	71	70	68	66	65	63
230	162	134	115	103	93	86	81	76	72	70	68	67	65	64	61
235	159	131	113	100	91	85	79	74	71	68	67	65	64	63	60
240	156	128	110	98	89	83	78	73	69	67	65	64	62	61	59
245	152	126	108	96	88	81	76	71	68	66	64	63	61	60	58
250	149	123	106	94	86	80	75	70	66	64	63	62	60	59	56

Note : For other steel grades not covered in Table 8.5, refer to Appendix 8.3.

Table 8.5t - Shear buckling strength q_w (N/mm²) of a web (for 16mm < $t \leq 40$ mm)

20) Grade Q460 steel, web thickness >16mm ≤ 40mm – design strength $p_y = 390$ N/mm ²															
d/t	Stiffener spacing ratio a/d														
	0.4	0.5	0.6	0.7	0.8	0.9	1.0	1.2	1.4	1.6	1.8	2.0	2.5	3.0	∞
55	234	234	234	234	234	234	234	234	234	234	234	234	234	233	228
60	234	234	234	234	234	234	234	234	234	234	230	228	224	222	217
65	234	234	234	234	234	234	234	233	227	223	220	218	214	211	206
70	234	234	234	234	234	234	233	224	218	213	210	207	203	201	195
75	234	234	234	234	234	232	224	215	208	204	200	197	193	190	183
80	234	234	234	234	233	224	216	206	199	194	190	187	182	179	172
85	234	234	234	234	226	216	207	197	189	184	180	177	172	169	162
90	234	234	234	230	219	208	199	188	180	174	170	167	162	159	153
95	234	234	234	224	211	200	191	179	171	165	161	158	153	151	145
100	234	234	232	217	204	192	182	170	162	157	153	150	146	143	138
105	234	234	226	210	197	184	174	162	154	149	146	143	139	136	131
110	234	234	220	204	189	177	166	154	147	142	139	136	132	130	125
115	234	233	214	197	182	169	158	148	141	136	133	130	127	125	120
120	234	228	208	190	175	162	152	141	135	130	127	125	121	119	115
125	234	223	202	184	167	155	146	136	130	125	122	120	117	115	110
130	234	218	196	177	161	149	140	131	125	120	118	115	112	110	106
135	234	213	190	170	155	144	135	126	120	116	113	111	108	106	102
140	233	207	184	164	150	139	130	121	116	112	109	107	104	102	98
145	228	202	179	159	144	134	126	117	112	108	105	103	100	99	95
150	224	197	173	153	140	129	121	113	108	104	102	100	97	96	92
155	220	192	167	148	135	125	117	110	104	101	99	97	94	92	89
160	216	187	162	144	131	121	114	106	101	98	95	94	91	90	86
165	212	182	157	139	127	118	110	103	98	95	93	91	88	87	83
170	207	177	152	135	123	114	107	100	95	92	90	88	86	84	81
175	203	172	148	131	120	111	104	97	93	89	87	86	83	82	79
180	199	167	144	128	116	108	101	94	90	87	85	83	81	80	76
185	195	162	140	124	113	105	98	92	88	85	83	81	79	77	74
190	191	158	136	121	110	102	96	89	85	82	80	79	77	75	72
195	186	154	133	118	107	99	93	87	83	80	78	77	75	73	71
200	182	150	129	115	105	97	91	85	81	78	76	75	73	72	69
205	178	146	126	112	102	95	89	83	79	76	75	73	71	70	67
210	174	143	123	110	100	92	87	81	77	75	73	71	69	68	66
215	169	140	120	107	97	90	85	79	75	73	71	70	68	67	64
220	166	136	118	105	95	88	83	77	74	71	69	68	66	65	63
225	162	133	115	102	93	86	81	75	72	70	68	67	65	64	61
230	158	130	112	100	91	84	79	74	70	68	66	65	63	62	60
235	155	128	110	98	89	83	77	72	69	67	65	64	62	61	59
240	152	125	108	96	87	81	76	71	67	65	64	63	61	60	57
245	149	122	106	94	85	79	74	69	66	64	62	61	59	58	56
250	146	120	103	92	84	78	73	68	65	63	61	60	58	57	55

Note : For other steel grades not covered in Table 8.5, refer to Appendix 8.3.

Table 8.5u - Shear buckling strength q_w (N/mm²) of a web (for $t \leq 16$ mm)

21) Grade Q550 steel, web thickness ≤ 16 mm – design strength $p_y = 520$ N/mm ²															
d/t	Stiffener spacing ratio a/d														
	0.4	0.5	0.6	0.7	0.8	0.9	1.0	1.2	1.4	1.6	1.8	2.0	2.5	3.0	∞
55	312	312	312	312	312	312	312	312	307	301	297	294	289	286	279
60	312	312	312	312	312	312	312	300	292	286	282	279	273	270	262
65	312	312	312	312	312	309	309	299	287	278	271	266	263	257	244
70	312	312	312	312	309	297	286	273	263	256	251	247	240	237	227
75	312	312	312	312	298	285	273	259	249	241	236	231	224	221	212
80	312	312	312	303	287	273	260	245	234	226	221	217	210	207	199
85	312	312	312	293	276	260	247	231	220	213	208	204	198	195	187
90	312	312	303	283	264	248	234	218	208	201	196	192	187	184	177
95	312	312	294	272	253	236	221	206	197	190	186	182	177	174	167
100	312	310	285	262	242	224	210	196	187	181	176	173	168	165	159
105	312	302	276	252	231	213	200	187	178	172	168	165	160	158	151
110	312	294	266	242	220	204	191	178	170	164	160	157	153	150	145
115	312	286	257	231	210	195	183	170	163	157	153	151	146	144	138
120	312	279	248	221	201	187	175	163	156	151	147	144	140	138	132
125	305	271	239	212	193	179	168	157	150	145	141	139	135	132	127
130	299	263	230	204	186	172	162	151	144	139	136	133	129	127	122
135	292	255	221	197	179	166	156	145	138	134	131	128	125	123	118
140	286	247	213	190	173	160	150	140	134	129	126	124	120	118	114
145	279	239	206	183	167	154	145	135	129	125	122	119	116	114	110
150	273	231	199	177	161	149	140	131	125	121	118	115	112	110	106
155	266	224	193	171	156	144	136	126	121	117	114	112	109	107	103
160	260	217	187	166	151	140	131	123	117	113	110	108	105	103	99
165	253	210	181	161	147	136	127	119	113	110	107	105	102	100	96
170	247	204	176	156	142	132	124	115	110	106	104	102	99	97	94
175	240	198	171	152	138	128	120	112	107	103	101	99	96	95	91
180	234	192	166	148	134	124	117	109	104	100	98	96	93	92	88
185	228	187	161	144	131	121	114	106	101	98	95	94	91	89	86
190	221	182	157	140	127	118	111	103	98	95	93	91	89	87	84
195	216	178	153	136	124	115	108	101	96	93	90	89	86	85	82
200	210	173	149	133	121	112	105	98	93	90	88	87	84	83	79
205	205	169	146	130	118	109	103	96	91	88	86	85	82	81	78
210	200	165	142	126	115	107	100	93	89	86	84	82	80	79	76
215	196	161	139	124	112	104	98	91	87	84	82	81	78	77	74
220	191	157	136	121	110	102	96	89	85	82	80	79	76	75	72
225	187	154	133	118	107	100	93	87	83	80	78	77	75	74	71
230	183	151	130	115	105	97	91	85	81	79	77	75	73	72	69
235	179	147	127	113	103	95	89	83	80	77	75	74	72	70	68
240	175	144	124	111	101	93	88	82	78	75	74	72	70	69	66
245	172	141	122	108	99	91	86	80	76	74	72	71	69	68	65
250	168	139	119	106	97	90	84	78	75	72	71	69	67	66	64

Note : For other steel grades not covered in Table 8.5, refer to Appendix 8.3.

Table 8.5v - Shear buckling strength q_w (N/mm²) of a web (for 16mm < $t \leq 40$ mm)

22) Grade Q550 steel, web thickness >16mm ≤ 40mm – design strength $p_y = 500$ N/mm ²															
d/t	Stiffener spacing ratio a/d														
	0.4	0.5	0.6	0.7	0.8	0.9	1.0	1.2	1.4	1.6	1.8	2.0	2.5	3.0	∞
55	300	300	300	300	300	300	300	300	298	293	289	286	281	278	272
60	300	300	300	300	300	300	300	292	284	279	275	271	266	263	255
65	300	300	300	300	300	300	290	279	271	265	260	256	251	247	239
70	300	300	300	300	300	289	278	266	257	250	245	242	235	232	223
75	300	300	300	300	290	277	266	253	243	236	231	227	220	216	208
80	300	300	300	295	279	266	254	240	229	222	216	212	206	203	195
85	300	300	300	285	269	254	242	226	216	209	204	200	194	191	183
90	300	300	294	275	258	243	229	214	204	197	192	189	183	180	173
95	300	300	286	265	247	231	217	202	193	187	182	179	174	171	164
100	300	300	277	256	237	220	206	192	183	177	173	170	165	162	156
105	300	294	269	246	226	209	196	183	175	169	165	162	157	155	148
110	300	286	260	236	216	200	187	175	167	161	157	154	150	147	142
115	300	279	251	227	206	191	179	167	159	154	150	148	143	141	136
120	300	271	243	217	198	183	172	160	153	148	144	142	137	135	130
125	297	264	234	208	190	176	165	154	147	142	138	136	132	130	125
130	290	256	226	200	182	169	159	148	141	136	133	131	127	125	120
135	284	249	217	193	176	163	153	142	136	131	128	126	122	120	115
140	278	242	209	186	169	157	147	137	131	127	124	121	118	116	111
145	272	234	202	180	163	151	142	133	126	122	119	117	114	112	108
150	266	227	195	174	158	146	137	128	122	118	115	113	110	108	104
155	260	219	189	168	153	142	133	124	118	114	112	110	106	105	101
160	254	212	183	163	148	137	129	120	115	111	108	106	103	101	97
165	248	206	177	158	144	133	125	117	111	107	105	103	100	98	94
170	242	200	172	153	139	129	121	113	108	104	102	100	97	95	92
175	235	194	167	149	135	125	118	110	105	101	99	97	94	93	89
180	229	189	163	145	132	122	115	107	102	98	96	94	92	90	87
185	223	184	158	141	128	119	111	104	99	96	94	92	89	88	84
190	217	179	154	137	125	116	109	101	96	93	91	89	87	85	82
195	212	174	150	134	122	113	106	99	94	91	89	87	85	83	80
200	206	170	146	130	119	110	103	96	92	89	86	85	82	81	78
205	201	166	143	127	116	107	101	94	89	86	84	83	80	79	76
210	196	162	139	124	113	105	98	92	87	84	82	81	79	77	74
215	192	158	136	121	110	102	96	89	85	82	80	79	77	75	73
220	187	154	133	118	108	100	94	87	83	81	79	77	75	74	71
225	183	151	130	116	105	98	92	85	81	79	77	75	73	72	69
230	179	148	127	113	103	95	90	84	80	77	75	74	72	71	68
235	176	145	125	111	101	93	88	82	78	75	74	72	70	69	66
240	172	142	122	109	99	92	86	80	76	74	72	71	69	68	65
245	168	139	120	106	97	90	84	78	75	72	71	69	67	66	64
250	165	136	117	104	95	88	82	77	73	71	69	68	66	65	62

Note : For other steel grades not covered in Table 8.5, refer to Appendix 8.3.

Table 8.5w - Shear buckling strength q_w (N/mm²) of a web (for $t \leq 16$ mm)

23) Grade Q690 steel, web thickness ≤ 16 mm – design strength $p_y = 630$ N/mm ²															
d/t	Stiffener spacing ratio a/d														
	0.4	0.5	0.6	0.7	0.8	0.9	1.0	1.2	1.4	1.6	1.8	2.0	2.5	3.0	∞
55	378	378	378	378	378	378	376	362	352	345	340	335	329	325	315
60	378	378	378	378	378	371	359	344	333	325	319	314	307	303	292
65	378	378	378	378	371	355	341	325	313	305	298	293	285	281	269
70	378	378	378	375	356	339	324	307	294	285	278	272	265	260	250
75	378	378	378	361	341	323	307	288	274	265	259	254	247	243	233
80	378	378	371	347	326	306	290	270	257	249	243	238	231	228	219
85	378	378	359	333	311	290	272	254	242	234	228	224	218	214	206
90	378	377	347	320	296	274	257	240	229	221	216	212	206	202	194
95	378	367	335	306	280	259	244	227	217	209	204	201	195	192	184
100	378	356	323	292	266	247	231	216	206	199	194	191	185	182	175
105	378	346	311	279	253	235	220	206	196	189	185	182	176	173	167
110	376	335	298	266	242	224	210	196	187	181	177	173	168	166	159
115	367	325	286	254	231	214	201	188	179	173	169	166	161	158	152
120	359	314	274	244	222	205	193	180	171	166	162	159	154	152	146
125	350	304	263	234	213	197	185	173	165	159	155	153	148	146	140
130	341	293	253	225	205	190	178	166	158	153	149	147	142	140	135
135	333	283	243	217	197	183	171	160	152	147	144	141	137	135	130
140	324	272	235	209	190	176	165	154	147	142	139	136	132	130	125
145	316	263	227	202	184	170	160	149	142	137	134	132	128	126	121
150	307	254	219	195	177	164	154	144	137	133	129	127	123	121	117
155	298	246	212	189	172	159	149	139	133	128	125	123	119	117	113
160	290	238	205	183	166	154	145	135	129	124	121	119	116	114	109
165	281	231	199	177	161	149	140	131	125	121	118	116	112	110	106
170	272	224	193	172	157	145	136	127	121	117	114	112	109	107	103
175	265	218	188	167	152	141	132	123	118	114	111	109	106	104	100
180	257	212	183	162	148	137	129	120	114	111	108	106	103	101	97
185	250	206	178	158	144	133	125	117	111	108	105	103	100	98	95
190	244	201	173	154	140	130	122	114	108	105	102	100	97	96	92
195	237	196	169	150	136	126	119	111	106	102	100	98	95	93	90
200	231	191	164	146	133	123	116	108	103	99	97	95	93	91	87
205	226	186	160	143	130	120	113	105	100	97	95	93	90	89	85
210	220	182	157	139	127	117	110	103	98	95	92	91	88	87	83
215	215	177	153	136	124	115	108	100	96	93	90	89	86	85	81
220	210	173	149	133	121	112	105	98	94	90	88	87	84	83	80
225	206	169	146	130	118	110	103	96	91	88	86	85	82	81	78
230	201	166	143	127	116	107	101	94	89	87	84	83	81	79	76
235	197	162	140	124	113	105	99	92	88	85	83	81	79	77	74
240	193	159	137	122	111	103	96	90	86	83	81	79	77	76	73
245	189	156	134	119	109	101	94	88	84	81	79	78	76	74	71
250	185	153	131	117	106	99	93	86	82	80	78	76	74	73	70

Note : For other steel grades not covered in Table 8.5, refer to Appendix 8.3.

Table 8.5x - Shear buckling strength q_w (N/mm²) of a web (for 16mm < $t \leq 40$ mm)

24) Grade Q690 steel, web thickness >16mm ≤ 40mm – design strength $p_y = 615$N/mm²															
d/t	Stiffener spacing ratio a/d														
	0.4	0.5	0.6	0.7	0.8	0.9	1.0	1.2	1.4	1.6	1.8	2.0	2.5	3.0	∞
55	369	369	369	369	369	369	369	356	346	339	334	330	323	320	310
60	369	369	369	369	369	365	353	338	328	320	314	310	303	298	288
65	369	369	369	369	364	349	336	320	309	301	294	290	282	277	266
70	369	369	369	368	350	334	319	302	290	281	274	269	261	257	247
75	369	369	369	355	335	318	303	284	271	262	256	251	244	240	231
80	369	369	365	341	321	302	286	267	254	246	240	235	229	225	216
85	369	369	353	328	306	287	269	251	239	231	226	222	215	212	203
90	369	369	341	315	292	271	254	237	226	218	213	209	203	200	192
95	369	360	330	302	277	256	241	224	214	207	202	198	193	189	182
100	369	350	318	289	263	244	229	213	203	197	192	188	183	180	173
105	369	340	306	275	250	232	218	203	194	187	183	179	174	171	165
110	369	330	294	263	239	221	208	194	185	179	174	171	166	164	157
115	361	320	283	251	229	212	199	185	177	171	167	164	159	156	150
120	353	310	271	241	219	203	191	178	169	164	160	157	152	150	144
125	344	300	260	231	210	195	183	171	163	157	153	151	146	144	138
130	336	290	250	222	202	187	176	164	156	151	148	145	141	138	133
135	328	279	241	214	195	180	169	158	151	146	142	140	136	133	128
140	319	269	232	206	188	174	163	152	145	140	137	135	131	129	123
145	311	260	224	199	181	168	158	147	140	136	132	130	126	124	119
150	303	251	216	193	175	162	152	142	136	131	128	126	122	120	115
155	294	243	209	186	170	157	148	138	131	127	124	122	118	116	112
160	286	235	203	181	164	152	143	133	127	123	120	118	114	112	108
165	278	228	197	175	159	148	139	129	123	119	116	114	111	109	105
170	269	222	191	170	155	143	135	125	120	116	113	111	108	106	102
175	261	215	186	165	150	139	131	122	116	112	110	108	105	103	99
180	254	209	180	160	146	135	127	118	113	109	107	105	102	100	96
185	247	204	176	156	142	132	124	115	110	106	104	102	99	97	93
190	241	198	171	152	138	128	120	112	107	103	101	99	96	95	91
195	235	193	167	148	135	125	117	109	104	101	98	97	94	92	89
200	229	188	162	144	131	122	114	107	102	98	96	94	91	90	86
205	223	184	158	141	128	119	112	104	99	96	94	92	89	88	84
210	218	179	155	138	125	116	109	102	97	94	91	90	87	86	82
215	213	175	151	134	122	113	106	99	95	91	89	88	85	84	80
220	208	171	148	131	120	111	104	97	92	89	87	86	83	82	79
225	203	167	144	128	117	108	102	95	90	87	85	84	81	80	77
230	199	164	141	126	114	106	99	93	88	85	83	82	80	78	75
235	195	160	138	123	112	104	97	91	87	84	82	80	78	77	74
240	191	157	135	120	110	101	95	89	85	82	80	78	76	75	72
245	187	154	133	118	107	99	93	87	83	80	78	77	75	73	71
250	183	151	130	116	105	97	91	85	81	79	77	75	73	72	69

Note : For other steel grades not covered in Table 8.5, refer to Appendix 8.3.

8.4.8 End anchorage

End anchorage is not required under either one of the following conditions:

a) Shear capacity, but not shear buckling resistance, governs the design as,

$$V_c = V_w \quad (8.47)$$

b) Sufficient shear buckling resistance is available without forming the tension field action as,

$$V \leq V_{cr} \quad (8.48)$$

in which V_{cr} is the critical shear buckling resistance without tension field given by,

If $V_w = V_c$, $V_{cr} = V_c$ (8.49)

If $V_c > V_w > 0.72 V_c$, $V_{cr} = (9V_w - 2V_c)/7$ (8.50)

If $V_w \leq 0.72 V_c$, $V_{cr} = (V_w/0.9)^2 / V_c$ (8.51)

in which V is the maximum shear force, V_w is the simple shear buckling resistance in clause 8.4.6 and V_c is the shear capacity.

When neither of the above conditions is satisfied, literature on design of plate girders should be referred to.

8.4.9 Panels with openings

For design of panels with an opening of any dimension larger than 10% of the minimum panel dimension, reference to specialist literature should be made. The panel should not be used as an anchor panel and the adjacent panel should be designed as an end panel.

8.4.10 Web capacity and stiffeners design

Stiffeners should be provided for unstiffened webs subjected to local loads or reactions as follows. Only the intermediate stiffeners in clause 8.4.7 and load bearing and load carrying stiffeners are covered in the Code. For design of other types of stiffeners, specialist literature should be referred to.

8.4.10.1 Maximum outstand of web stiffeners

Except for the outer edge of a web stiffener stiffened continuously, its outstand from the face of the web should not exceed $19 \epsilon t_s$.

If the outstand of a stiffener is larger than $13 \epsilon t_s$ but smaller than $19 \epsilon t_s$ its design should be based on an effective cross-section with an outstand of $13 \epsilon t_s$.

8.4.10.2 Stiff bearing length

The stiff bearing length b_1 is used in the width of stress bearing area and should be taken as the length of support that cannot deform appreciably in bending. To determine b_1 , the dispersion of load through a steel bearing is shown in Figure 8.3. Dispersion at 45° through packs may be assumed provided that they are firmly fixed in position.

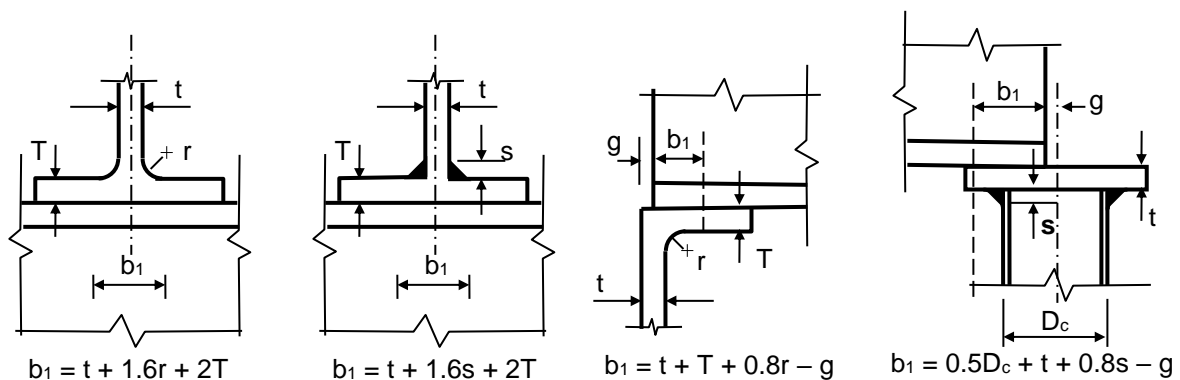

Figure 8.3 - Stiff bearing length

8.4.10.3 *Eccentricity*

When a load or reaction is applied eccentrically from the centreline of the web, or when the centroid of the stiffener does not lie on the centreline of the web, the resulting eccentricity of loading should be allowed for in design.

8.4.10.4 *Hollow sections*

Where concentrated loads are applied to hollow sections, consideration should be given to local stresses and deformations. The section should be reinforced or stiffened as necessary.

8.4.10.5 *Bearing capacity of webs*

8.4.10.5.1 Bearing capacity of unstiffened webs

Bearing stiffeners should be provided where the local compressive force F_x applied through a flange by loads or reactions exceeds the bearing capacity P_{bw} of the unstiffened web at the web-to-flange connection given by:

$$P_{bw} = (b_1 + nk) t p_{yw} \quad (8.52)$$

in which

at the ends of a member:

$$n = 2 + 0.6b_e / k \leq 5 \quad (8.53)$$

at other locations

- $n = 5$

- For rolled I- or H-sections: $k = T + r$ (8.54)

- For welded I- or H-sections: $k = T$ (8.55)

where

b_1 is the stiff bearing length, see clause 8.4.10.2;

b_e is the distance to the nearer end of the member from the end of the stiff bearing;

p_{yw} is the design strength of the web;

r is the root radius;

T is the flange thickness;

t is the web thickness.

8.4.10.5.2 Bearing capacity of stiffened web

Bearing stiffeners should be designed for the applied force F_x minus the bearing capacity P_{bw} of the unstiffened web. The capacity P_s of the stiffener should be obtained from:

$$P_s = A_{s.net} p_y \quad (8.56)$$

in which $A_{s.net}$ is the net cross-sectional area of the stiffener, allowing for cope holes for welding.

If the web and the stiffener have different design strengths, the smaller value should be used to calculate both the web capacity P_{bw} and the stiffener capacity P_s .

8.4.10.6 *Buckling resistance of webs*

8.4.10.6.1 Buckling resistance of unstiffened web

Load carrying web stiffeners should be provided where the local compressive force F_x applied through a flange by a load or reaction exceeds the buckling resistance of the web. P_x should be calculated as follows.

When the flange through which the load or reaction is applied is effectively restrained against both:

a) rotation relative to the web;

b) lateral movement relative to the other flange;

then provided that the distance a_e from the load or reaction to the nearer end of the member is at least $0.7d$, the buckling resistance of the unstiffened web should be taken as P_x below:

$$P_x = \frac{25 \varepsilon t}{\sqrt{(b_1 + nk)d}} P_{bw} \quad (8.57)$$

where

d is the depth of the web;

P_{bw} is the bearing capacity of the unstiffened web at the web-to-flange connection, from clause 8.4.10.5.1.

When the distance a_e from the load or reaction to the nearer end of the member is less than $0.7d$, the buckling resistance P_x of the web should be taken as:

$$P_x = \frac{a_e + 0.7d}{1.4d} \frac{25 \varepsilon t}{\sqrt{(b_1 + nk)d}} P_{bw} \quad (8.58)$$

When the condition a) or b) is not met, the buckling resistance of the web should be reduced to P_{xr} given by:

$$P_{xr} = \frac{0.7d}{L_E} P_x \quad (8.59)$$

in which L_E is the effective length of the web, acting as a compression member or a part of a compression member.

8.4.10.6.2 Buckling resistance of load carrying stiffeners

Load carrying web stiffeners should be added where the local compressive stress f_{ed} on the compression edge of a web, due to loads or reactions applied through a flange between the web stiffeners already provided, exceeds the compressive strength for edge loading p_{ed} .

For this check, the stress f_{ed} on the compression edge of a web panel of depth d between two transverse stiffeners of spacing a should be calculated as follows:

- points loads and distributed loads of load-span shorter than the smaller panel dimension a or d should be divided by the smaller panel dimension;
- for a series of equally spaced and similar point loads, divide the largest load by the spacing, or by the smaller panel dimension if this is less;
- add the intensity (force/unit length) of any other distributed loads;
- divide the sum of (a), (b) or (c) by the web thickness t .

The compressive strength for edge loading p_{ed} should be calculated as follows:

- if the compression flange is restrained against rotation relative to the web:

$$p_{ed} = \left[2.75 + \frac{2}{(a/d)^2} \right] \frac{E}{(d/t)^2} \quad (8.60)$$

- if the compression flange is not restrained against rotation relative to the web:

$$p_{ed} = \left[1.0 + \frac{2}{(a/d)^2} \right] \frac{E}{(d/t)^2} \quad (8.61)$$

The load or reactions F_x on a load carrying stiffener should not exceed the buckling resistance P_x of the stiffener, given by:

$$P_x = A_s p_c \quad (8.62)$$

The effective area A_s of the load carrying stiffener should be taken as that of a cruciform cross-section made up from the effective area of the stiffeners themselves (see clause 8.4.10.1) together with an effective width of web on each side of the centreline of the stiffeners with limit of 15 times the web thickness t .

The compressive strength p_c should be determined from clause 8.7.6 using strut curve “c” (see Table 8.8) and the radius of gyration of the complete cruciform area A_s of the stiffener about its axis parallel to the web.

The design strength p_y should be taken as the lower value for the web or the stiffeners. The reduction of 20 N/mm² for welded sections in clause 8.7.6 should be applied when the stiffeners themselves are welded sections.

Provided that the flange through which the load or reaction is applied is effectively restrained against lateral movement relative to the other flange, the effective length L_E should be taken as follows:

- (a) flanges are restrained against rotation in the plane of the stiffener by other structural elements:

$$L_E = 0.7 \text{ times the length } L \text{ of the stiffener clear between flanges;}$$

- (b) flanges are not restrained in (a) above:

$$L_E = 1.0 \text{ times the length } L \text{ of the stiffener clear between flanges.}$$

If the load or reaction is applied to the flange by a compression member and the effective lateral restraint is provided at this point, the stiffener should be designed as part of the compression member applying the load and the connection should be checked for the effects of strut action.

If the stiffener also acts as an intermediate transverse stiffener to resist shear buckling, it should be checked for the effect of combined loads in accordance with clause 8.4.7.5.

Load carrying stiffeners should also be checked as bearing stiffeners, see clause 8.4.10.5.2.

8.4.11 Other types of stiffeners

Specialist literature should be referred to for design and use of various other types of stiffeners such as tension stiffeners, diagonal stiffeners, intermediate transverse web stiffeners, torsion stiffeners etc.

8.4.12 Connections between web stiffeners and webs

Stiffeners can be connected to webs by fitted bolts, preloaded bolts and welds. This connection should be designed to transmit a load equal to the least of the following:

- a) The sum of forces at both ends when the forces are in the same direction.
- b) The larger of the forces when they are in opposite directions.
- c) The capacity of the stiffeners.

8.4.13 Connections between web stiffeners and flanges

8.4.13.1 Stiffeners in compression

Web stiffeners required to resist compression should be either (a) fitted against the loaded flange or (b) connected to it by continuous welds, fitted bolts or preloaded bolts designed for non-slip under factored loads.

The stiffener should be fitted against or connected to both flanges when any one of the following applies.

- a) A load is directly above a support.
- b) The stiffener forms the end stiffener of a stiffened web.
- c) The stiffener acts as a torsional stiffener (refer to specialist literature for design of torsional stiffeners).

8.4.13.2 Stiffeners in tension

Web stiffeners required to resist tension should be connected to the flange transmitting the load or the reaction using continuous welds, fitted bolts or preloaded bolts designed to be non-slip under factored loads. This connection should be designed to resist the least of the applied load, reaction or the capacity of the stiffeners according to clause 8.4.10.5.2.

8.4.13.3 Length of web stiffeners

Bearing stiffeners or tension stiffeners performing a single function may be curtailed at a length such that the capacity P_{us} of the unstiffened web beyond the end of the stiffener is not less than that part of the applied load or reaction carried by the stiffener. P_{us} can be calculated as,

$$P_{us} = (b_1 + w) t p_{yw} \quad (8.63)$$

where

b_1 is the stiff bearing length in clause 8.4.10.2;

w is the length obtained by a dispersion at 45° to the level where the stiffener curtailed;

p_{yw} is the design strength of web.

8.5 BUCKLING RESISTANCE MOMENT FOR SINGLE ANGLE MEMBERS

An angle bent about an axis parallel to its leg should be checked against lateral-torsional buckling. It can be checked using the following method, or alternatively, and for unequal angle sections, by methods given in specialist literature or by carrying out buckling analysis.

For equal angle with $b/t \leq 15\varepsilon$ and bent about x-axis, the resistance moment is given by,
 $M_b = 0.8p_y Z_x$ for heel of angle in compression (8.64)

$$M_b = p_y Z_x \left(\frac{1350\varepsilon - L_E / r_v}{1625\varepsilon} \right) \leq 0.8p_y Z_x \text{ for heel of angle in tension} \quad (8.65)$$

where

L_E is the effective length from clause 8.3.4 using L_v as the distance between restraints against buckling about v-axis;

r_v is the radius of gyration about the v-axis;

Z_x is the smaller section modulus about x-axis.

8.6 TENSION MEMBERS

8.6.1 Tension capacity

The tension capacity P_t of a member is generally taken as,

$$P_t = p_y A_e \quad (8.66)$$

in which A_e is the sum of effective areas a_e of all elements in the cross-section in clause 9.3.4.4.

8.6.2 Members with eccentric connections

Members with eccentric connections can generally be considered as in uniaxial or biaxial bending and designed using clause 8.8. However, angles, channels or T-sections with eccentric end connections may be designed using a reduced tension capacity as follows.

8.6.3 Single and double angle, channel and T-sections

For a single angle section connected through one leg, a single channel through the web or a single T-section through the flange, the tension capacity should be obtained as,

$$\text{for bolted connections, } P_t = p_y (A_e - 0.5a_2) \quad (8.67)$$

$$\text{for welded connections, } P_t = p_y (A_e - 0.3a_2) \quad (8.68)$$

where

$$a_2 = A_g - a_1; \quad (8.69)$$

A_g is the sum of gross cross-sectional area defined in clause 9.3.4.1 ;

a_1 is the gross area of the connected leg, taken as the product of thickness and the leg length of an angle, the depth of a channel or the flange width of a T-section.

For angles connected separately on the same side of a gusset or member, checking in clause 8.8 should also be applied.

8.6.4 Double angle, channel and T-sections with intermediate connections

For double angles, channels and T-sections connected on both sides of a gusset plate and interconnected by bolts or welds by at least 2 battens or solid packing pieces within their length, their tension capacity should be obtained as follows.

$$\text{For bolted connections, } P_t = p_y (A_e - 0.25a_2) \quad (8.70)$$

$$\text{For welded connections, } P_t = p_y (A_e - 0.15a_2) \quad (8.71)$$

8.7 COMPRESSION MEMBERS

8.7.1 Segment length

A segment length L of a compression member in any plane is defined as the length between the points at which the member is restrained against translation in that plane.

8.7.2 Effective length in general

Use of the effective length method for design shall satisfy the condition in clause 6.6. The effective length L_E of a compression member should be taken as the equivalent length of a pin-ended member with identical buckling resistance. When necessary, an imaginarily extended member length is required for estimation of this effective length. A general equivalent length factor is indicated in Table 8.6. Refer to clause 6.6.4 for slenderness ratio limits.

Except for angles, channels and T-sections designed to clause 8.7.9, the effective length L_E of a compression member or its buckling effects should be determined from a buckling analysis or other recognised methods. The guidelines given below may be used to determine the effective length factor for simple columns whose boundary conditions which can be reliably approximated in design.

- a) A restraining member carrying more than 90% of its capacity to clause 8.9 should not be considered as being capable of providing a lateral directional restraint.
- b) The effective length of continuous columns in multi-storey frames depends on conditions of restraint in the relevant plane, directional and rotational restraints, connection stiffness and member stiffness. Clause 6.6.3 should be referred to for determination of effective length factor.
- c) Columns under a variable axial force along their lengths and varying sectional properties should be designed using an analytical method, a second-order analysis or an advanced plastic analysis.
- d) The effective length recommended for design differs from the theoretical values in Table 8.6 because of uncertainty in boundary assumptions.
- e) The buckling resistance of sloping members with moment-resisting connections cannot be determined by the effective length method or the moment amplification method, because of possible snap-through buckling. Second-order or advanced analysis should be used in this case.

For more accurate assessments of buckling resistance of compression members, elastic critical load analysis, second-order P- Δ - δ analysis or advanced analysis should be used. The P- Δ - δ analysis should be carried out as an alternative to the effective length method for the analysis and design of structures with ultimate load affected considerably by buckling. Columns with both ends pinned in a sway frame or leaning should not be designed by the effective length method.

Table 8.6 - Effective length of idealized columns

Flexural Buckling						
Buckled shape of column shown by dashed line						
Theoretical K value	0.5	0.7	1.0	1.0	2.0	/
Recommended K value when ideal conditions are approximated	0.70	0.85	1.20	1.00	2.10	1.5
End condition code						
		Rotation fixed. Transition fixed.				
		Rotation free. Transition fixed.				
		Rotation fixed. Transition free.				
		Rotation free. Transition free.				
		Rotation partially restrained. Transition free.				

8.7.3 Restraints

A restraint should have adequate strength and stiffness to limit movement of the restrained point in position, direction or both. A positional restraint should have adequate stiffness to prevent significant lateral displacement and adequate strength to resist a minimum of 1% of the axial force in the member being restrained. When the bracing member is restraining more than one member, a reduction factor should be applied to the resistance force requirement of the restraint as follows:-

$$k_r = \sqrt{0.2 + \frac{1}{N_r}} \leq 1 \quad (8.72)$$

in which N_r is the number of parallel members being restrained.

8.7.4 Slenderness

The slenderness of a compression member should be taken as the effective length divided by the radius of gyration about the axis considered for buckling.

8.7.5 Compression resistance

The compression resistance P_c of a member should be obtained from,

For Class 1 plastic, Class 2 compact and Class 3 semi-compact cross sections,

$$P_c = A_g p_c \quad (8.73)$$

For Class 4 slender cross-sections,

$$P_c = A_{eff} p_{cs} \quad (8.74)$$

in which

A_{eff} is the effective cross-sectional area in clause 7.6;

A_g is the sum of gross sectional area in clause 9.3.4.1;

p_c is the compressive strength in clause 8.7.6;

p_{cs} is the value of p_c obtained using a reduced slenderness of $\lambda \sqrt{\frac{A_{eff}}{A_g}}$ where λ is the slenderness ratio calculated from the radius of gyration of the gross sectional area and effective length.

8.7.6 Compressive strength

The compressive strength p_c should be based on the type of section, design strength, slenderness and a suitable buckling curve a_0, a, b, c or d that should be selected from Table 8.7. The value p_c for these buckling curves should be obtained from Tables 8.8(a), 8.8(a) to 8.8(h) and Figure 8.4 or, alternatively, by the formulae in Appendix 8.4.

For welded I, H or box sections, p_y should be reduced by 20 N/mm² and p_c should then be determined on the basis of this reduced p_y .

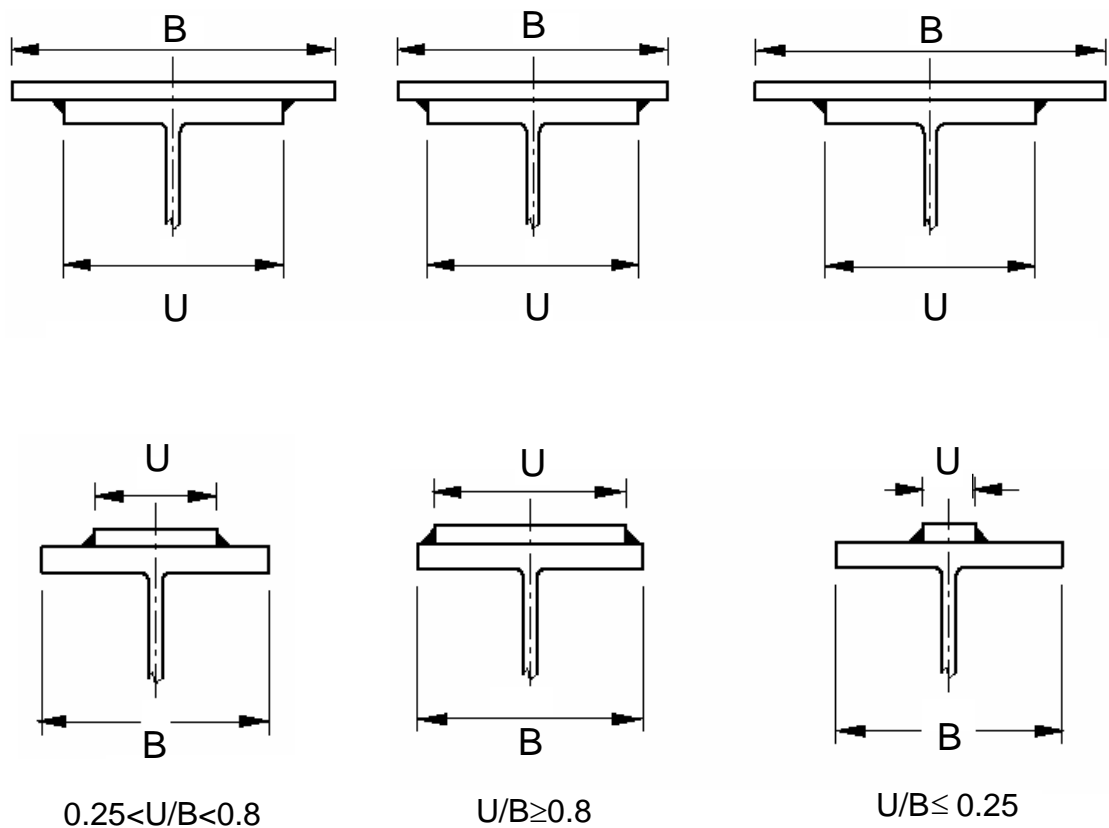

Figure 8.4 - Rolled I- or H-sections with welded flange plates

Table 8.7 - Designation of buckling curves for different section types

Type of section	Maximum thickness (see note1)	Axis of buckling	
		x-x	y-y
Hot-finished structural hollow sections with steel grade \geq S460 or hot-finished seamless structural hollow sections		a ₀)	a ₀)
Hot-finished structural hollow section < grade S460		a)	a)
Cold-formed structural hollow section of longitudinal seam weld or spiral weld		c)	c)
Rolled I-section	≤ 40 mm > 40 mm	a) b)	b) c)
Rolled H-section	≤ 40 mm > 40 mm	b) c)	c) d)
Welded I- or H-section (see note 2)	≤ 40 mm > 40 mm	b) b)	c) d)
Rolled I-section with welded flange cover plates with $0.25 < U/B < 0.80$ as shown in Figure 8.4)	≤ 40 mm > 40 mm	a) b)	b) c)
Rolled H-section with welded flange cover plates with $0.25 < U/B < 0.80$ as shown in Figure 8.4)	≤ 40 mm > 40 mm	b) c)	c) d)
Rolled I or H-section with welded flange cover plates with $U/B \geq 0.80$ as shown in Figure 8.4)	≤ 40 mm > 40 mm	b) c)	a) b)
Rolled I or H-section with welded flange cover plates with $U/B \leq 0.25$ as shown in Figure 8.4)	≤ 40 mm > 40 mm	b) b)	c) d)
Welded box section (see note 3)	≤ 40 mm > 40 mm	b) c)	b) c)
Round, square or flat bar	≤ 40 mm > 40 mm	b) c)	b) c)
Rolled angle, channel or T-section Two rolled sections laced, battened or back-to-back Compound rolled sections		Any axis: c)	
NOTE:			
<ol style="list-style-type: none"> For thickness between 40mm and 50mm the value of p_c may be taken as the average of the values for thicknesses up to 40mm and over 40mm for the relevant value of p_y. For welded I or H-sections with their flanges thermally cut by machine without subsequent edge grinding or machining, for buckling about the y-y axis, strut curve b) may be used for flanges up to 40mm thick and strut curve c) for flanges over 40mm thick. The category "welded box section" includes any box section fabricated from plates or rolled sections, provided that all of the longitudinal welds are near the corners of the cross-section. Box sections with longitudinal stiffeners are NOT included in this category. Use of buckling curves based on other recognized design codes allowing for variation between load and material factors and calibrated against Tables 8.8(a₀), (a) to (h) is acceptable. See also footnote under Table 8.8. 			

Table 8.8(a) - Design strength p_c of compression members

Values of p_c in N/mm ² for strut curve a_0											
λ	Steel grade and design strength (N/mm ²) S460 with $\lambda < 110$					λ	Steel grade and design strength (N/mm ²) S460 with $\lambda \geq 110$				
	400	410	430	440	460		400	410	430	440	460
15	399	409	429	439	458	110	150	150	151	152	153
20	396	405	425	434	454	112	145	146	147	147	148
25	391	401	420	430	449	114	141	141	142	142	143
30	387	396	415	425	443	116	136	137	137	138	138
35	381	391	409	418	437	118	132	132	133	133	134
40	375	384	402	411	429	120	128	128	129	129	130
42	372	381	399	408	425	122	124	124	125	125	126
44	369	378	395	404	421	124	120	121	121	122	122
46	366	375	391	400	417	126	117	117	118	118	118
48	362	371	387	395	412	128	113	114	114	115	115
50	359	367	383	391	406	130	110	111	111	111	112
52	354	362	378	385	400	135	103	103	103	104	104
54	350	357	372	379	393	140	96	96	96	97	97
56	344	352	366	373	386	145	90	90	90	90	91
58	339	346	359	365	378	150	84	84	85	85	85
60	333	339	352	358	369	155	79	79	79	79	80
62	326	332	344	349	360	160	74	74	75	75	75
64	319	325	335	340	350	165	70	70	70	70	71
66	312	317	327	331	340	170	66	66	66	66	67
68	304	308	317	321	329	175	63	63	63	63	63
70	296	300	308	311	318	180	59	59	59	60	60
72	287	291	298	301	307	185	56	56	56	56	57
74	278	282	288	291	296	190	53	53	54	54	54
76	270	273	278	281	286	195	51	51	51	51	51
78	261	264	269	271	275	200	48	48	48	48	49
80	252	255	259	261	265	210	44	44	44	44	44
82	244	246	250	251	255	220	40	40	40	40	40
84	235	237	241	242	245	230	37	37	37	37	37
86	227	229	232	233	236	240	34	34	34	34	34
88	219	221	223	225	227	250	31	31	31	31	31
90	212	213	215	216	219	260	29	29	29	29	29
92	204	205	208	209	210	270	27	27	27	27	27
94	197	198	200	201	203	280	25	25	25	25	25
96	190	191	193	194	195	290	23	23	23	23	23
98	184	185	186	187	188	300	22	22	22	22	22
100	177	178	180	180	182	310	20	20	20	21	21
102	171	172	174	174	175	320	19	19	19	19	19
104	166	166	168	168	169	330	18	18	18	18	18
106	160	161	162	163	163	340	17	17	17	17	17
108	155	156	157	157	158	350	16	16	16	16	16

Note : For other steel grades, refer to Appendix 8.4.

Table 8.8(a) - Design strength p_c of compression members

1) Values of p_c in N/mm ² with $\lambda < 110$ for strut curve a															
λ	Steel grade and design strength p_y (N/mm ²)														
	S275					S355					S460				
	235	245	255	265	275	315	325	335	345	355	400	410	430	440	460
15	235	245	255	265	275	315	325	335	345	355	399	409	429	439	458
20	234	244	254	264	273	312	322	332	342	351	395	405	424	434	453
25	232	241	251	261	270	309	318	328	338	347	390	400	419	429	448
30	229	239	248	258	267	305	315	324	333	343	385	395	414	423	442
35	226	236	245	254	264	301	310	320	329	338	380	389	407	416	434
40	223	233	242	251	260	296	305	315	324	333	373	382	399	408	426
42	222	231	240	249	258	294	303	312	321	330	370	378	396	404	422
44	221	230	239	248	257	292	301	310	319	327	366	375	392	400	417
46	219	228	237	246	255	280	299	307	316	325	363	371	388	396	413
48	218	227	236	244	253	288	296	305	313	322	359	367	383	391	407
50	216	225	234	242	251	285	293	302	310	318	355	363	378	386	401
52	215	223	232	241	249	282	291	299	307	315	350	358	373	380	395
54	213	222	230	238	247	279	287	295	303	311	345	353	367	374	388
56	211	220	228	236	244	276	284	292	300	307	340	347	361	368	381
58	210	218	226	234	242	273	281	288	295	303	334	341	354	360	372
60	208	216	224	232	239	269	277	284	291	298	328	334	346	352	364
62	206	214	221	229	236	266	273	280	286	293	321	327	338	344	354
64	204	211	219	226	234	262	268	275	281	288	314	320	330	335	344
66	201	209	216	223	230	257	264	270	276	282	307	312	321	326	334
68	199	206	213	220	227	253	259	265	270	276	299	303	312	316	324
70	196	203	210	217	224	248	254	259	265	270	291	295	303	306	313
72	194	201	207	214	220	243	248	253	258	263	282	286	293	296	302
74	191	198	204	210	216	238	243	247	252	256	274	277	283	286	292
76	188	194	200	206	212	232	237	241	245	249	265	268	274	276	281
78	185	191	197	202	208	227	231	235	239	242	257	259	264	267	271
80	182	188	193	198	203	221	225	229	232	235	248	251	255	257	261
82	179	184	189	194	199	215	219	222	225	228	240	242	246	248	251
84	176	181	185	190	194	209	213	216	219	221	232	234	237	239	242
86	172	177	181	186	190	204	207	209	212	214	224	225	229	230	233
88	169	173	177	181	185	198	200	203	205	208	216	218	220	222	224
90	165	169	173	177	180	192	195	197	199	201	209	210	213	214	216
92	162	166	169	173	176	186	189	191	193	194	201	203	205	206	208
94	158	162	165	168	171	181	183	185	187	188	194	196	198	199	200
96	154	158	161	164	166	175	177	179	181	182	188	189	191	192	193
98	151	154	157	159	162	170	172	173	175	176	181	182	184	185	186
100	147	150	153	155	157	165	167	168	169	171	175	176	178	178	180
102	144	146	149	151	153	160	161	163	164	165	169	170	172	172	174
104	140	142	145	147	149	155	156	158	159	160	164	165	166	166	168
106	136	139	141	143	145	150	152	153	154	155	158	159	160	161	162
108	133	135	137	139	141	146	147	148	149	150	153	154	155	156	157

Note : For other steel grades, refer to Appendix 8.4.

Table 8.8(a) - Design strength p_c of compression members (cont'd)

2) Values of p_c in N/mm ² with $\lambda \geq 110$ for strut curve a															
λ	Steel grade and design strength p_y (N/mm ²)														
	S275					S355					S460				
	235	245	255	265	275	315	325	335	345	355	400	410	430	440	460
110	130	132	133	135	137	142	143	144	144	145	148	149	150	150	151
112	126	128	130	131	133	137	138	139	140	141	144	144	145	146	146
114	123	125	126	128	129	133	134	135	136	136	139	140	141	141	142
116	120	121	123	124	125	129	130	131	132	132	135	135	136	137	137
118	117	118	120	121	122	126	126	127	128	128	131	131	132	132	133
120	114	115	116	118	119	122	123	123	123	125	127	127	128	128	129
122	111	112	113	114	115	119	119	120	120	121	123	123	124	124	125
124	108	109	110	111	112	115	116	116	117	117	119	120	120	121	121
126	105	106	107	108	109	112	113	113	114	114	116	116	117	117	118
128	103	104	105	105	106	109	109	110	110	111	112	113	113	114	114
130	100	101	102	103	103	106	106	107	107	108	109	110	110	110	111
135	94	95	95	96	97	99	99	100	100	101	102	102	103	103	103
140	88	89	90	90	91	93	93	93	94	94	95	95	96	96	96
145	83	84	84	85	85	87	87	87	88	88	89	89	90	90	90
150	78	79	79	80	80	82	82	82	82	83	83	84	84	84	84
155	74	74	75	75	75	77	77	77	77	78	78	79	79	79	79
160	70	70	70	71	71	72	72	73	73	73	74	74	74	74	75
165	66	66	67	67	67	68	68	69	69	69	70	70	70	70	70
170	62	63	63	63	64	64	65	65	65	65	66	66	66	66	66
175	59	59	60	60	60	61	61	61	61	62	62	62	62	63	63
180	56	56	57	57	57	58	58	58	58	58	59	59	59	59	59
185	53	54	54	54	54	55	55	55	55	55	56	56	56	56	56
190	51	51	51	51	52	52	52	52	53	53	53	53	53	53	53
195	48	49	49	49	49	50	50	50	50	50	50	51	51	51	51
200	46	46	46	47	47	47	47	47	48	48	48	48	48	48	48
210	42	42	42	43	43	43	43	43	43	43	44	44	44	44	44
220	39	39	39	39	39	39	39	40	40	40	40	40	40	40	40
230	35	36	36	36	36	36	36	36	36	36	37	37	37	37	37
240	33	33	33	33	33	33	33	33	33	33	34	34	34	34	34
250	30	30	30	30	30	31	31	31	31	31	31	31	31	31	31
260	28	28	28	28	28	28	29	29	29	29	29	29	29	29	29
270	26	26	26	26	26	26	27	27	27	27	27	27	27	27	27
280	24	24	24	24	24	25	25	25	25	25	25	25	25	25	25
290	23	23	23	23	23	23	23	23	23	23	23	23	23	23	23
300	21	21	21	21	21	22	22	22	22	22	22	22	22	22	22
310	20	20	20	20	20	20	20	20	20	20	20	20	20	20	20
320	19	19	19	19	19	19	19	19	19	19	19	19	19	19	19
330	18	18	18	18	18	18	18	18	18	18	18	18	18	18	18
340	17	17	17	17	17	17	17	17	17	17	17	17	17	17	17
350	16	16	16	16	16	16	16	16	16	16	16	16	16	16	16

Note : For other steel grades, refer to Appendix 8.4.

Table 8.8(b) - Design strength p_c of compression members

i) S275 ~ S460 steel

3) Values of p_c in N/mm ² with $\lambda < 110$ for strut curve b															
λ	Steel grade and design strength p_y (N/mm ²)														
	S275					S355					S460				
	235	245	255	265	275	315	325	335	345	355	400	410	430	440	460
15	235	245	255	265	275	315	325	335	345	355	399	409	428	438	457
20	234	243	253	263	272	310	320	330	339	349	391	401	420	429	448
25	229	239	248	258	267	304	314	323	332	342	384	393	411	421	439
30	225	234	243	253	262	298	307	316	325	335	375	384	402	411	429
35	220	229	238	247	256	291	300	309	318	327	366	374	392	400	417
40	216	224	233	241	250	284	293	301	310	318	355	364	380	388	404
42	213	222	231	239	248	281	289	298	306	314	351	359	375	383	399
44	211	220	228	237	245	278	286	294	302	310	346	354	369	377	392
46	209	218	226	234	242	275	283	291	298	306	341	349	364	371	386
48	207	215	223	231	239	271	279	287	294	302	336	343	358	365	379
50	205	213	221	229	237	267	275	283	290	298	330	337	351	358	372
52	203	210	218	226	234	264	271	278	286	293	324	331	344	351	364
54	200	208	215	223	230	260	267	274	281	288	318	325	337	344	356
56	198	205	213	220	227	256	263	269	276	283	312	318	330	336	347
58	195	202	210	217	224	252	258	265	271	278	305	311	322	328	339
60	193	200	207	214	221	247	254	260	266	272	298	304	314	320	330
62	190	197	204	210	217	243	249	255	261	266	291	296	306	311	320
64	187	194	200	207	213	238	244	249	255	261	284	289	298	302	311
66	184	191	197	203	210	233	239	244	249	255	276	281	289	294	301
68	181	188	194	200	206	228	233	239	244	249	269	273	281	285	292
70	178	185	190	196	202	223	228	233	238	242	261	265	272	276	282
72	175	181	187	193	198	218	223	227	232	236	254	257	264	267	273
74	172	178	183	189	194	213	217	222	226	230	246	249	255	258	264
76	169	175	180	185	190	208	212	216	220	223	238	241	247	250	255
78	166	171	176	181	186	203	206	210	214	217	231	234	239	241	246
80	163	168	172	177	181	197	201	204	208	211	224	226	231	233	237
82	160	164	169	173	177	192	196	199	202	205	217	219	223	225	229
84	156	161	165	169	173	187	190	193	196	199	210	212	216	218	221
86	153	157	161	165	169	182	185	188	190	193	203	205	208	210	213
88	150	154	158	161	165	177	180	182	185	187	196	198	201	203	206
90	146	150	154	157	161	172	175	177	179	181	190	192	195	196	199
92	143	147	150	153	156	167	170	172	174	176	184	185	188	189	192
94	140	143	147	150	152	162	165	167	169	171	178	179	182	183	185
96	137	140	143	146	148	158	160	162	164	165	172	173	176	177	179
98	134	137	139	142	145	153	155	157	159	160	167	168	170	171	173
100	130	133	136	138	141	149	151	152	154	155	161	162	164	165	167
102	127	130	132	135	137	145	146	148	149	151	156	157	159	160	162
104	124	127	129	131	133	141	142	144	145	146	151	152	154	155	156
106	121	124	126	128	130	137	138	139	141	142	147	148	149	150	151
108	118	121	123	125	126	133	134	135	137	138	142	143	144	145	147

Note : For other steel grades, refer to Appendix 8.4.

Table 8.8(b) - Design strength p_c of compression members (cont'd)

i) S275 ~ S460 steel

4) Values of p_c in N/mm ² with $\lambda \geq 110$ for strut curve b															
λ	Steel grade and design strength p_y (N/mm ²)														
	S275					S355					S460				
	235	245	255	265	275	315	325	335	345	355	400	410	430	440	460
110	115	118	120	121	123	129	130	131	133	134	138	139	140	141	142
112	113	115	117	118	120	125	127	128	129	130	134	134	136	136	138
114	110	112	114	115	117	122	123	124	125	126	130	130	132	132	133
116	107	109	111	112	114	119	120	121	122	122	126	126	128	128	129
118	105	106	108	109	111	115	116	117	118	119	122	123	124	124	125
120	102	104	105	107	108	112	113	114	115	116	119	119	120	121	122
122	100	101	103	104	105	109	110	111	112	112	115	116	117	117	118
124	97	99	100	101	102	106	107	108	109	109	112	112	113	114	115
126	95	96	98	99	100	103	104	105	106	106	109	109	110	111	111
128	93	94	95	96	97	101	101	102	103	103	106	106	107	107	108
130	90	92	93	94	95	98	99	99	100	101	103	103	104	105	105
135	85	86	87	88	89	92	93	93	94	94	96	97	97	98	98
140	80	81	82	83	84	86	87	87	88	88	90	90	91	91	92
145	76	77	78	78	79	81	82	82	83	83	84	85	85	86	86
150	72	72	73	74	74	76	77	77	78	78	79	80	80	80	81
155	68	69	69	70	70	72	72	73	73	73	75	75	75	76	76
160	64	65	65	66	66	68	68	69	69	69	70	71	71	71	72
165	61	62	62	62	63	64	65	65	65	65	66	67	67	67	68
170	58	58	59	59	60	61	61	61	62	62	63	63	63	64	64
175	55	55	56	56	57	58	58	58	59	59	60	60	60	60	60
180	52	53	53	53	54	55	55	55	56	56	56	57	57	57	57
185	50	50	51	51	51	52	52	53	53	53	54	54	54	54	54
190	48	48	48	48	49	50	50	50	50	50	51	51	51	51	52
195	45	46	46	46	46	47	47	48	48	48	49	49	49	49	49
200	43	44	44	44	44	45	45	45	46	46	46	46	47	47	47
210	40	40	40	40	41	41	41	41	42	42	42	42	42	43	43
220	36	37	37	37	37	38	38	38	38	38	39	39	39	39	39
230	34	34	34	34	34	35	35	35	35	35	35	36	36	36	36
240	31	31	31	31	32	32	32	32	32	32	33	33	33	33	33
250	29	29	29	29	29	30	30	30	30	30	30	30	30	30	30
260	27	27	27	27	27	27	28	28	28	28	28	28	28	28	28
270	25	25	25	25	25	26	26	26	26	26	26	26	26	26	26
280	23	23	23	23	24	24	24	24	24	24	24	24	24	24	24
290	22	22	22	22	22	22	22	22	22	22	23	23	23	23	23
300	20	20	21	21	21	21	21	21	21	21	21	21	21	21	21
310	19	19	19	19	19	20	20	20	20	20	20	20	20	20	20
320	18	18	18	18	18	18	18	19	19	19	19	19	19	19	19
330	17	17	17	17	17	17	17	17	17	18	18	18	18	18	18
340	16	16	16	16	16	16	16	16	17	17	17	17	17	17	17
350	15	15	15	15	15	16	16	16	16	16	16	16	16	16	16

Note : For other steel grades, refer to Appendix 8.4.

Table 8.8(b) - Design strength p_c of compression members

ii) S550 ~ S690 steel

5) Values of p_c in N/mm² with $\lambda < 110$ for strut curve b						
λ	Steel grade and design strength p_y (N/mm²)					
	S550			S690		
	490	530	550	630	650	690
15	486	525	544	621	641	679
20	477	515	534	609	628	665
25	467	504	522	595	613	650
30	456	491	509	579	596	631
35	443	477	494	560	576	608
40	428	460	476	537	551	580
42	422	452	467	526	540	567
44	415	444	459	514	528	553
46	408	436	449	502	514	538
48	400	427	440	489	500	522
50	391	417	429	475	485	505
52	383	407	418	460	470	488
54	373	396	406	445	454	470
56	364	385	394	429	437	452
58	354	373	382	414	421	434
60	344	361	369	398	404	416
62	333	349	357	382	388	398
64	323	337	344	367	372	381
66	312	326	332	352	356	364
68	302	314	319	337	341	348
70	292	302	307	323	327	333
72	281	291	295	310	313	319
74	271	280	284	297	300	305
76	262	270	273	285	287	292
78	252	259	263	273	275	279
80	243	250	252	262	264	268
82	234	240	243	251	253	257
84	226	231	234	241	243	246
86	218	223	225	232	233	236
88	210	214	216	223	224	227
90	202	206	208	214	216	218
92	195	199	201	206	207	209
94	188	192	193	199	200	201
96	182	185	186	191	192	194
98	176	179	180	184	185	187
100	170	172	174	178	179	180
102	164	167	168	171	172	174
104	159	161	162	165	166	168
106	153	156	157	160	160	162
108	148	150	151	154	155	156

Note : For other steel grades, refer to Appendix 8.4.

Table 8.8(b) - Design strength p_c of compression members (cont'd)

ii) S550 ~ S690 steel (cont'd)

5) Values of p_c in N/mm² with $\lambda \geq 110$ for strut curve b						
λ	Steel grade and design strength p_y (N/mm²)					
	S550			S690		
	490	530	550	630	650	690
110	144	146	146	149	150	151
112	139	141	142	144	145	146
114	135	136	137	140	140	141
116	131	132	133	135	136	137
118	127	128	129	131	132	132
120	123	124	125	127	127	128
122	119	121	121	123	124	124
124	116	117	118	119	120	121
126	112	114	114	116	116	117
128	109	110	111	113	113	114
130	106	107	108	109	110	110
135	99	100	100	102	102	103
140	93	93	94	95	95	96
145	87	87	88	89	89	89
150	81	82	82	83	83	84
155	76	77	77	78	78	79
160	72	73	73	74	74	74
165	68	68	69	69	70	70
170	64	65	65	65	66	66
175	61	61	61	62	62	62
180	58	58	58	59	59	59
185	55	55	55	56	56	56
190	52	52	52	53	53	53
195	49	50	50	50	50	51
200	47	47	47	48	48	48
210	43	43	43	44	44	44
220	39	39	39	40	40	40
230	36	36	36	36	37	37
240	33	33	33	34	34	34
250	31	31	31	31	31	31
260	28	28	29	29	29	29
270	26	26	26	27	27	27
280	25	25	25	25	25	25
290	23	23	23	23	23	23
300	21	22	22	22	22	22
310	20	20	20	20	20	20
320	19	19	19	19	19	19
330	18	18	18	18	18	18
340	17	17	17	17	17	17
350	16	16	16	16	16	16

Note : For other steel grades, refer to Appendix 8.4.

Table 8.8(c) - Design strength p_c of compression members

i) S275 ~ S460 steel

5) Values of p_c in N/mm ² with $\lambda < 110$ for strut curve c															
λ	Steel grade and design strength p_y (N/mm ²)														
	S275					S355					S460				
	235	245	255	265	275	315	325	335	345	355	400	410	430	440	460
15	235	245	255	265	275	315	325	335	345	355	398	408	427	436	455
20	233	242	252	261	271	308	317	326	336	345	387	396	414	424	442
25	226	235	245	254	263	299	308	317	326	335	375	384	402	410	428
30	220	228	237	246	255	289	298	307	315	324	363	371	388	396	413
35	213	221	230	238	247	280	288	296	305	313	349	357	374	382	397
40	206	214	222	230	238	270	278	285	293	301	335	343	358	365	380
42	203	211	219	227	235	266	273	281	288	296	329	337	351	358	373
44	200	208	216	224	231	261	269	276	284	291	323	330	344	351	365
46	197	205	213	220	228	257	264	271	279	286	317	324	337	344	357
48	195	202	209	217	224	253	260	267	274	280	311	317	330	337	349
50	192	199	206	213	220	248	255	262	268	275	304	310	323	329	341
52	189	196	203	210	217	244	250	257	263	270	297	303	315	321	333
54	186	193	199	206	213	239	245	252	258	264	291	296	308	313	324
56	183	189	196	202	209	234	240	246	252	258	284	289	300	305	315
58	179	186	192	199	205	229	235	241	247	252	277	282	292	297	306
60	176	183	189	195	201	225	230	236	241	247	270	274	284	289	298
62	173	179	185	191	197	220	225	230	236	241	262	267	276	280	289
64	170	176	182	188	193	215	220	225	230	235	255	260	268	272	280
66	167	173	178	184	189	210	215	220	224	229	248	252	260	264	271
68	164	169	175	180	185	205	210	214	219	223	241	245	252	256	262
70	161	166	171	176	181	200	204	209	213	217	234	238	244	248	254
72	157	163	168	172	177	195	199	203	207	211	227	231	237	240	246
74	154	159	164	169	173	190	194	198	202	205	220	223	229	232	238
76	151	156	160	165	169	185	189	193	196	200	214	217	222	225	230
78	148	152	157	161	165	180	184	187	191	194	207	210	215	217	222
80	145	149	153	157	161	176	179	182	185	188	201	203	208	210	215
82	142	146	150	154	157	171	174	177	180	183	195	197	201	203	207
84	139	142	146	150	154	167	169	172	175	178	189	191	195	197	201
86	135	139	143	146	150	162	165	168	170	173	183	185	189	190	194
88	132	136	139	143	146	158	160	163	165	168	177	179	183	184	187
90	129	133	136	139	142	153	156	158	161	163	172	173	177	178	181
92	126	130	133	136	139	149	152	154	156	158	166	168	171	173	175
94	124	127	130	133	135	145	147	149	151	153	161	163	166	167	170
96	121	124	127	129	132	141	143	145	147	149	156	158	160	162	164
98	118	121	123	126	129	137	139	141	143	145	151	153	155	157	159
100	115	118	120	123	125	134	135	137	139	140	147	148	151	152	154
102	113	115	118	120	122	130	132	133	135	136	143	144	146	147	149
104	110	112	115	117	119	126	128	130	131	133	138	139	142	142	144
106	107	110	112	114	116	123	125	126	127	129	134	135	137	138	140
108	105	107	109	111	113	120	121	123	124	125	130	131	133	134	136

Note : For other steel grades, refer to Appendix 8.4.

Table 8.8(c) - Design strength p_c of compression members (cont'd)

i) S275 ~ S460 steel (cont'd)

6) Values of p_c in N/mm ² with $\lambda \geq 110$ for strut curve c															
λ	Steel grade and design strength p_y (N/mm ²)														
	S275					S355					S460				
	235	245	255	265	275	315	325	335	345	355	400	410	430	440	460
110	102	104	106	108	110	116	118	119	120	122	126	127	129	130	132
112	100	102	104	106	107	113	115	116	117	118	123	124	125	126	128
114	98	100	101	103	105	110	112	113	114	115	119	120	122	123	124
116	95	97	99	101	102	108	109	110	111	112	116	117	118	119	120
118	93	95	97	98	100	105	106	107	108	109	113	114	115	116	117
120	91	93	94	96	97	102	103	104	105	106	110	110	112	112	113
122	89	90	92	93	95	99	100	101	102	103	107	107	109	109	110
124	87	88	90	91	92	97	98	99	100	100	104	104	106	106	107
126	85	86	88	89	90	94	95	96	97	98	101	102	103	103	104
128	83	84	86	87	88	92	93	94	95	95	98	99	100	100	101
130	81	82	84	85	86	90	91	91	92	93	96	96	97	98	99
135	77	78	79	80	81	84	85	86	87	87	90	90	91	92	92
140	72	74	75	76	76	79	80	81	81	82	84	85	85	86	87
145	69	70	71	71	72	75	76	76	77	77	79	80	80	81	81
150	65	66	67	68	68	71	71	72	72	73	75	75	76	76	76
155	62	63	63	64	65	67	67	68	68	69	70	71	71	72	72
160	59	59	60	61	61	63	64	64	65	65	66	67	67	67	68
165	56	56	57	58	58	60	60	61	61	61	63	63	64	64	64
170	53	54	54	55	55	57	57	58	58	58	60	60	60	60	61
175	51	51	52	52	53	54	54	55	55	55	56	57	57	57	58
180	48	49	49	50	50	51	52	52	52	53	54	54	54	54	55
185	46	46	47	47	48	49	49	50	50	50	51	51	52	52	52
190	44	44	45	45	45	47	47	47	47	48	49	49	49	49	49
195	42	42	43	43	43	45	45	45	45	45	46	46	47	47	47
200	40	41	41	41	42	43	43	43	43	43	44	44	45	45	45
210	37	37	38	38	38	39	39	39	40	40	40	40	41	41	41
220	34	34	35	35	35	36	36	36	36	36	37	37	37	37	38
230	31	32	32	32	32	33	33	33	33	34	34	34	34	34	35
240	29	29	30	30	30	30	31	31	31	31	31	31	32	32	32
250	27	27	27	28	28	28	28	28	29	29	29	29	29	29	29
260	25	25	26	26	26	26	26	26	27	27	27	27	27	27	27
270	23	24	24	24	24	24	25	25	25	25	25	25	25	25	25
280	22	22	22	22	22	23	23	23	23	23	23	24	24	24	24
290	21	21	21	21	21	21	21	22	22	22	22	22	22	22	22
300	19	19	20	20	20	20	20	20	20	20	21	21	21	21	21
310	18	18	18	19	19	19	19	19	19	19	19	19	19	19	20
320	17	17	17	17	18	18	18	18	18	18	18	18	18	18	18
330	16	16	16	16	17	17	17	17	17	17	17	17	17	17	17
340	15	15	15	16	16	16	16	16	16	16	16	16	16	16	16
350	15	15	15	15	15	15	15	15	15	15	15	15	15	15	15

Note : For other steel grades, refer to Appendix 8.4.

Table 8.8(c) - Design strength p_c of compression members

ii) S550 ~ S690 steel

5) Values of p_c in N/mm² with $\lambda < 110$ for strut curve c						
λ	Steel grade and design strength p_y (N/mm²)					
	S550			S690		
	490	530	550	630	650	690
15	484	522	541	617	636	673
20	470	506	525	598	616	652
25	455	490	507	577	595	629
30	439	472	489	554	571	603
35	421	452	468	529	544	573
40	402	431	445	500	513	539
42	394	421	435	487	500	524
44	385	412	425	474	486	509
46	377	402	414	461	472	493
48	368	392	403	447	457	477
50	359	381	392	432	442	460
52	349	370	380	418	427	443
54	340	359	369	404	412	427
56	330	348	357	389	396	410
58	320	337	345	375	381	394
60	310	326	334	361	367	378
62	301	315	322	347	352	362
64	291	305	311	333	338	347
66	281	294	300	320	325	333
68	272	284	289	308	312	319
70	263	273	278	295	299	306
72	254	264	268	284	287	293
74	245	254	258	272	276	281
76	237	245	249	262	265	270
78	228	236	240	252	254	259
80	221	228	231	242	244	248
82	213	219	222	232	235	239
84	206	212	214	224	226	229
86	199	204	207	215	217	220
88	192	197	199	207	209	212
90	185	190	192	200	201	204
92	179	184	186	192	194	197
94	173	177	179	186	187	189
96	167	171	173	179	180	183
98	162	166	167	173	174	176
100	157	160	162	167	168	170
102	152	155	156	161	162	164
104	147	150	151	156	157	158
106	142	145	146	151	152	153
108	138	141	142	146	147	148

Note : For other steel grades, refer to Appendix 8.4.

Table 8.8(c) - Design strength p_c of compression members (cont'd)

ii) S550 ~ S690 steel (cont'd)

5) Values of p_c in N/mm² with $\lambda \geq 110$ for strut curve c						
λ	Steel grade and design strength p_y (N/mm²)					
	S550			S690		
	490	530	550	630	650	690
110	134	136	137	141	142	143
112	130	132	133	137	137	139
114	126	128	129	132	133	134
116	122	124	125	128	129	130
118	119	120	121	124	125	126
120	115	117	118	121	121	122
122	112	114	114	117	118	119
124	109	110	111	114	114	115
126	106	107	108	110	111	112
128	103	104	105	107	108	109
130	100	101	102	104	105	106
135	93	95	95	97	98	98
140	88	89	89	91	91	92
145	82	83	84	85	86	86
150	77	78	79	80	80	81
155	73	74	74	75	75	76
160	69	69	70	71	71	72
165	65	66	66	67	67	67
170	61	62	62	63	63	64
175	58	59	59	60	60	60
180	55	56	56	57	57	57
185	52	53	53	54	54	54
190	50	50	51	51	51	52
195	47	48	48	49	49	49
200	45	46	46	46	47	47
210	41	42	42	42	42	43
220	38	38	38	39	39	39
230	35	35	35	36	36	36
240	32	32	32	33	33	33
250	30	30	30	30	30	30
260	28	28	28	28	28	28
270	26	26	26	26	26	26
280	24	24	24	24	24	24
290	22	22	22	23	23	23
300	21	21	21	21	21	21
310	20	20	20	20	20	20
320	18	19	19	19	19	19
330	17	17	18	18	18	18
340	16	16	17	17	17	17
350	16	16	16	16	16	16

Note : For other steel grades, refer to Appendix 8.4.

Table 8.8(d) - Design strength p_c of compression members

i) S275 ~ S460 steel

7) Values of p_c in N/mm ² with $\lambda < 110$ for strut curve d															
λ	Steel grade and design strength p_y (N/mm ²)														
	S275					S355					S460				
	235	245	255	265	275	315	325	335	345	355	400	410	430	440	460
15	235	245	255	265	275	315	325	335	345	355	397	407	425	435	453
20	232	241	250	259	269	305	314	323	332	341	381	390	408	417	434
25	223	231	240	249	257	292	301	309	318	326	365	373	390	398	415
30	213	222	230	238	247	279	287	296	304	312	348	356	372	380	396
35	204	212	220	228	236	267	274	282	290	297	331	339	353	361	375
40	195	203	210	218	225	254	261	268	275	283	314	321	334	341	355
42	192	199	206	214	221	249	256	263	270	277	307	314	327	333	346
44	188	195	202	209	216	244	251	257	264	271	300	306	319	325	337
46	185	192	199	205	212	239	245	252	258	265	293	299	311	317	329
48	181	188	195	201	208	234	240	246	252	259	286	291	303	309	320
50	178	184	191	197	204	228	235	241	247	253	278	284	295	301	311
52	174	181	187	193	199	223	229	235	241	246	271	277	287	292	303
54	171	177	183	189	195	218	224	229	235	240	264	269	279	284	294
56	167	173	179	185	191	213	219	224	229	234	257	262	271	276	285
58	164	170	175	181	187	208	213	218	224	229	250	255	264	268	277
60	161	166	172	177	182	203	208	213	218	223	243	247	256	260	268
62	157	163	168	173	178	198	203	208	212	217	236	240	248	252	260
64	154	159	164	169	174	193	198	202	207	211	229	233	241	245	252
66	150	156	160	165	170	188	193	197	201	205	223	226	234	237	244
68	147	152	157	162	166	184	188	192	196	200	216	220	226	230	236
70	144	149	153	158	162	179	183	187	190	194	210	213	219	222	228
72	141	145	150	154	158	174	178	182	185	189	203	207	213	215	221
74	138	142	146	150	154	170	173	177	180	183	197	200	206	209	214
76	135	139	143	147	151	165	169	172	175	178	191	194	199	202	207
78	132	136	139	143	147	161	164	167	170	173	186	188	193	195	200
80	129	132	136	140	143	156	160	163	165	168	180	182	187	189	194
82	126	129	133	136	140	152	155	158	161	163	175	177	181	183	187
84	123	126	130	133	136	148	151	154	156	159	169	171	176	177	181
86	120	123	127	130	133	144	147	149	152	154	164	166	170	172	175
88	117	120	123	127	129	140	143	145	148	150	159	161	165	167	170
90	114	118	121	123	126	137	139	141	144	146	154	156	160	161	164
92	112	115	118	120	123	133	135	137	139	142	150	152	155	156	159
94	109	112	115	117	120	129	132	134	136	138	145	147	150	152	154
96	107	109	112	115	117	126	128	130	132	134	141	143	146	147	150
98	104	107	109	112	114	123	125	126	128	130	137	138	141	143	145
100	102	104	107	109	111	119	121	123	125	126	133	134	137	138	141
102	99	102	104	106	108	116	118	120	121	123	129	131	133	134	136
104	97	99	102	104	106	113	115	116	118	120	126	127	129	130	132
106	95	97	99	101	103	110	112	113	115	116	122	123	125	126	128
108	93	95	97	99	101	107	109	110	112	113	119	120	122	123	125

Note : For other steel grades, refer to Appendix 8.4.

Table 8.8(d) - Design strength p_c of compression members (cont'd)

i) S275 ~ S460 steel (cont'd)

8) Values of p_c in N/mm ² with $\lambda \geq 110$ for strut curve d															
λ	Steel grade and design strength p_y (N/mm ²)														
	S275					S355					S460				
	235	245	255	265	275	315	325	335	345	355	400	410	430	440	460
110	91	93	95	96	98	105	106	108	109	110	115	116	118	119	121
112	88	90	92	94	96	102	103	105	106	107	112	113	115	116	118
114	86	88	90	92	94	99	101	102	103	104	109	110	112	113	114
116	85	86	88	90	91	97	98	99	101	102	106	107	109	110	111
118	83	84	86	88	89	95	96	97	98	99	103	104	106	107	108
120	81	82	84	86	87	92	93	94	95	96	101	101	103	104	105
122	79	81	82	84	85	90	91	92	93	94	98	99	100	101	102
124	77	79	80	82	83	88	89	90	91	92	95	96	98	98	99
126	76	77	78	80	81	86	87	88	89	89	93	94	95	96	97
128	74	75	77	78	79	84	85	85	86	87	91	91	93	93	94
130	72	74	75	76	77	82	83	83	84	85	88	89	90	91	92
135	68	70	71	72	73	77	78	79	79	80	83	84	85	85	86
140	65	66	67	68	69	73	73	74	75	75	78	79	80	80	81
145	62	63	64	65	65	69	69	70	71	71	74	74	75	75	76
150	59	60	60	61	62	65	66	66	67	67	69	70	71	71	72
155	56	57	57	58	59	62	62	63	63	64	66	66	67	67	68
160	53	54	55	55	56	58	59	59	60	60	62	62	63	63	64
165	50	51	52	53	53	55	56	56	57	57	59	59	60	60	61
170	48	49	49	50	51	53	53	54	54	54	56	56	57	57	57
175	46	47	47	48	48	50	51	51	51	52	53	53	54	54	55
180	44	45	45	46	46	48	48	49	49	49	50	51	51	51	52
185	42	43	43	44	44	46	46	46	47	47	48	48	49	49	49
190	40	41	41	42	42	44	44	44	44	45	46	46	46	47	47
195	38	39	39	40	40	42	42	42	42	43	44	44	44	45	45
200	37	37	38	38	39	40	40	40	41	41	42	42	42	43	43
210	34	34	35	35	35	37	37	37	37	37	38	38	39	39	39
220	31	32	32	32	33	34	34	34	34	34	35	35	36	36	36
230	29	29	30	30	30	31	31	31	32	32	32	33	33	33	33
240	27	27	28	28	28	29	29	29	29	29	30	30	30	30	31
250	25	25	26	26	26	27	27	27	27	27	28	28	28	28	28
260	24	24	24	24	24	25	25	25	25	25	26	26	26	26	26
270	22	22	22	23	23	23	23	23	24	24	24	24	24	24	25
280	21	21	21	21	21	22	22	22	22	22	23	23	23	23	23
290	19	20	20	20	20	20	21	21	21	21	21	21	21	21	21
300	18	18	19	19	19	19	19	19	19	20	20	20	20	20	20
310	17	17	17	18	18	18	18	18	18	18	19	19	19	19	19
320	16	16	16	17	17	17	17	17	17	17	18	18	18	18	18
330	15	15	16	16	16	16	16	16	16	16	17	17	17	17	17
340	15	15	15	15	15	15	15	15	15	15	16	16	16	16	16
350	14	14	14	14	14	14	14	15	15	15	15	15	15	15	15

Note : For other steel grades, refer to Appendix 8.4.

Table 8.8(d) - Design strength p_c of compression members

ii) S550 ~ S690 steel

5) Values of p_c in N/mm² with $\lambda < 110$ for strut curve d						
λ	Steel grade and design strength p_y (N/mm²)					
	S550			S690		
	490	530	550	630	650	690
15	481	518	537	611	629	666
20	461	496	514	584	602	637
25	440	474	490	557	573	606
30	419	450	466	527	542	572
35	397	426	440	496	509	536
40	374	400	413	463	475	498
42	365	390	402	449	460	482
44	356	379	391	435	446	466
46	346	369	380	421	431	450
48	337	358	368	407	416	434
50	327	347	357	393	402	418
52	317	336	345	379	387	403
54	308	326	334	366	373	387
56	298	315	323	352	359	372
58	289	305	312	339	346	357
60	280	294	301	327	332	343
62	271	284	291	314	319	329
64	262	275	281	302	307	316
66	253	265	271	291	295	304
68	245	256	261	279	284	291
70	237	247	252	269	273	280
72	229	238	243	258	262	269
74	221	230	234	249	252	258
76	214	222	226	239	242	248
78	206	214	218	230	233	238
80	200	207	210	222	224	229
82	193	200	203	214	216	220
84	186	193	196	206	208	212
86	180	186	189	198	201	204
88	174	180	183	191	193	197
90	169	174	176	185	186	190
92	163	168	170	178	180	183
94	158	163	165	172	174	177
96	153	157	159	166	168	170
98	148	152	154	161	162	165
100	144	148	149	155	157	159
102	139	143	145	150	152	154
104	135	139	140	145	147	149
106	131	134	136	141	142	144
108	127	130	132	136	137	139

Note : For other steel grades, refer to Appendix 8.4.

Table 8.8(d) - Design strength p_c of compression members (cont'd)

ii) S550 ~ S690 steel (cont'd)

5) Values of p_c in N/mm² with $\lambda \geq 110$ for strut curve d						
λ	Steel grade and design strength p_y (N/mm²)					
	S550			S690		
	490	530	550	630	650	690
110	123	126	128	132	133	135
112	120	123	124	128	129	131
114	116	119	120	124	125	127
116	113	116	117	121	121	123
118	110	112	113	117	118	119
120	107	109	110	114	114	116
122	104	106	107	110	111	112
124	101	103	104	107	108	109
126	98	100	101	104	105	106
128	96	98	99	101	102	103
130	93	95	96	99	99	100
135	87	89	90	92	93	94
140	82	84	84	86	87	88
145	77	78	79	81	81	82
150	73	74	74	76	77	77
155	69	70	70	72	72	73
160	65	66	66	68	68	69
165	61	62	63	64	64	65
170	58	59	59	61	61	61
175	55	56	56	57	58	58
180	52	53	53	54	55	55
185	50	51	51	52	52	52
190	48	48	48	49	49	50
195	45	46	46	47	47	47
200	43	44	44	45	45	45
210	40	40	40	41	41	41
220	36	37	37	37	38	38
230	33	34	34	34	34	35
240	31	31	31	32	32	32
250	29	29	29	29	29	30
260	27	27	27	27	27	27
270	25	25	25	25	25	26
280	23	23	23	24	24	24
290	22	22	22	22	22	22
300	20	20	20	21	21	21
310	19	19	19	19	19	20
320	18	18	18	18	18	18
330	17	17	17	17	17	17
340	16	16	16	16	16	16
350	15	15	15	15	15	15

Note : For other steel grades, refer to Appendix 8.4.

Table 8.8(e) - Design strength p_c of compression members

Values of p_c in N/mm ² with $\lambda < 110$ for strut curve a					
λ	Steel grade and design strength (N/mm ²)				
	Q235	Q345/Q355	Q390	Q420	Q460
	215	305	345	375	410
15	215	305	345	375	409
20	215	303	342	371	405
25	212	299	338	366	400
30	210	296	333	362	395
35	208	292	329	357	389
40	205	287	324	350	382
42	204	285	321	348	378
44	203	283	319	345	375
46	201	281	316	342	371
48	200	279	313	338	367
50	199	277	310	335	363
52	198	274	307	331	358
54	196	271	303	327	353
56	195	268	300	322	347
58	193	265	295	317	341
60	191	262	291	312	334
62	190	259	286	306	327
64	188	255	281	300	320
66	186	251	276	293	312
68	184	247	270	287	303
70	182	242	265	279	295
72	180	237	258	272	286
74	178	233	252	265	277
76	175	227	245	257	268
78	173	222	239	249	259
80	170	217	232	241	251
82	168	211	225	234	242
84	165	206	219	226	234
86	162	200	212	219	225
88	159	195	205	212	218
90	156	189	199	205	210
92	153	184	193	198	203
94	150	179	187	191	196
96	147	173	181	185	189
98	144	168	175	179	182
100	141	163	169	173	176
102	137	158	164	167	170
104	134	154	159	162	165
106	131	149	154	157	159
108	128	145	149	152	154

Note : For other steel grades, refer to Appendix 8.4.

Table 8.8(e) - Design strength p_c of compression members (cont'd)

Values of p_c in N/mm ² with $\lambda \geq 110$ for strut curve a					
λ	Steel grade and design strength (N/mm ²)				
	Q235	Q345/Q355	Q390	Q420	Q460
	215	305	345	375	410
110	125	140	144	147	149
112	122	136	140	142	144
114	119	132	136	138	140
116	116	129	132	134	135
118	113	125	128	129	131
120	111	121	124	126	127
122	108	118	120	122	123
124	105	115	117	118	120
126	103	111	114	115	116
128	100	108	110	112	113
130	98	105	107	108	110
135	92	98	100	101	102
140	86	92	94	95	95
145	81	86	88	88	89
150	77	81	82	83	84
155	73	76	77	78	79
160	69	72	73	73	74
165	65	68	69	69	70
170	62	64	65	65	66
175	58	61	61	62	62
180	55	58	58	59	59
185	53	55	55	56	56
190	50	52	53	53	53
195	48	50	50	50	51
200	46	47	48	48	48
210	42	43	43	44	44
220	38	39	40	40	40
230	35	36	36	36	37
240	32	33	33	34	34
250	30	31	31	31	31
260	28	28	29	29	29
270	26	26	27	27	27
280	24	25	25	25	25
290	23	23	23	23	23
300	21	22	22	22	22
310	20	20	20	20	20
320	19	19	19	19	19
330	18	18	18	18	18
340	17	17	17	17	17
350	16	16	16	16	16

Note : For other steel grades, refer to Appendix 8.4.

Table 8.8(f) - Design strength p_c of compression members

Values of p_c in N/mm ² with $\lambda < 110$ for strut curve b							
λ	Steel grade and design strength (N/mm ²)						
	Q235	Q345/Q355	Q390	Q420	Q460	Q550	Q690
	215	305	345	375	410	520	630
15	215	305	345	375	409	515	621
20	215	301	339	368	401	505	609
25	211	295	332	360	393	494	595
30	207	289	325	353	384	482	579
35	202	283	318	344	374	468	560
40	198	276	310	335	364	452	537
42	196	273	306	331	359	445	526
44	194	270	302	326	354	437	514
46	193	267	298	322	349	429	502
48	191	263	294	317	343	420	489
50	189	260	290	312	337	411	475
52	187	256	286	307	331	401	460
54	185	253	281	302	325	390	445
56	182	249	276	296	318	380	429
58	180	245	271	290	311	368	414
60	178	241	266	284	304	357	398
62	176	236	261	278	296	346	382
64	173	232	255	271	289	334	367
66	171	227	249	265	281	322	352
68	168	223	244	258	273	311	337
70	166	218	238	251	265	300	323
72	163	213	232	244	257	289	310
74	161	208	226	237	249	278	297
76	158	204	220	230	241	268	285
78	155	199	214	224	234	258	273
80	153	194	208	217	226	248	262
82	150	189	202	210	219	239	251
84	147	184	196	204	212	230	241
86	144	179	190	198	205	221	232
88	141	174	185	191	198	213	223
90	138	169	179	185	192	206	214
92	136	165	174	180	185	198	206
94	133	160	169	174	179	191	199
96	130	156	164	169	173	184	191
98	127	151	159	163	168	178	184
100	124	147	154	158	162	172	178
102	121	143	149	153	157	166	171
104	119	139	145	149	152	160	165
106	116	135	141	144	148	155	160
108	113	131	137	140	143	150	154

Note : For other steel grades, refer to Appendix 8.4.

Table 8.8(f) - Design strength p_c of compression members (cont'd)

Values of p_c in N/mm ² with $\lambda \geq 110$ for strut curve b							
λ	Steel grade and design strength (N/mm ²)						
	Q235	Q345/Q355	Q390	Q420	Q460	Q550	Q690
	215	305	345	375	410	520	630
110	111	128	133	136	139	145	149
112	108	124	129	132	134	140	144
114	106	121	125	128	130	136	140
116	103	117	122	124	126	132	135
118	101	114	118	120	123	128	131
120	99	111	115	117	119	124	127
122	96	108	112	114	116	120	123
124	94	105	109	111	112	117	119
126	92	103	106	107	109	113	116
128	90	100	103	105	106	110	113
130	88	97	100	102	103	107	109
135	83	91	94	95	97	100	102
140	78	86	88	89	90	93	95
145	74	81	83	84	85	87	89
150	70	76	78	79	80	82	83
155	66	72	73	74	75	77	78
160	63	68	69	70	71	72	74
165	60	64	65	66	67	68	69
170	57	61	62	62	63	65	65
175	54	58	59	59	60	61	62
180	51	55	56	56	57	58	59
185	49	52	53	53	54	55	56
190	47	49	50	51	51	52	53
195	45	47	48	48	49	50	50
200	43	45	46	46	46	47	48
210	39	41	42	42	42	43	44
220	36	38	38	38	39	39	40
230	33	35	35	35	36	36	36
240	31	32	32	32	33	33	34
250	28	30	30	30	30	31	31
260	26	27	28	28	28	28	29
270	25	26	26	26	26	26	27
280	23	24	24	24	24	25	25
290	22	22	22	23	23	23	23
300	20	21	21	21	21	23	23
310	19	20	20	20	20	20	20
320	18	18	19	19	19	19	19
330	17	17	17	18	18	18	18
340	16	16	17	17	17	17	17
350	15	16	16	16	16	16	16

Note : For other steel grades, refer to Appendix 8.4.

Table 8.8(g) - Design strength p_c of compression members

Values of p_c in N/mm ² with $\lambda < 110$ for strut curve c							
λ	Steel grade and design strength (N/mm ²)						
	Q235	Q345/Q355	Q390	Q420	Q460	Q550	Q690
	215	305	345	375	410	520	630
15	215	305	345	374	408	512	617
20	214	299	336	364	396	497	598
25	208	290	326	353	384	481	577
30	202	281	315	341	371	464	554
35	196	272	305	329	357	445	529
40	190	262	293	316	343	424	500
42	187	258	288	311	337	415	487
44	185	254	284	305	330	405	474
46	182	250	279	300	324	396	461
48	180	246	274	294	317	386	447
50	177	241	268	288	310	375	432
52	174	237	263	282	303	365	418
54	172	232	258	276	296	354	404
56	169	228	252	270	289	344	389
58	166	223	247	263	282	333	375
60	164	219	241	257	274	322	361
62	161	214	236	251	267	312	347
64	158	210	230	244	260	301	333
66	155	205	224	238	252	291	320
68	152	200	219	231	245	281	308
70	150	195	213	225	238	271	295
72	147	191	207	219	231	261	284
74	144	186	202	212	223	252	272
76	141	181	196	206	217	243	262
78	139	177	191	200	210	234	252
80	136	172	185	194	203	226	242
82	133	168	180	188	197	218	232
84	130	163	175	183	191	210	224
86	128	159	170	177	185	203	215
88	125	155	165	172	179	196	207
90	122	151	161	167	173	189	200
92	120	147	156	162	168	183	192
94	117	143	151	157	163	176	186
96	114	139	147	152	158	170	179
98	112	135	143	148	153	165	173
100	109	132	139	143	148	159	167
102	107	128	135	139	144	154	161
104	105	125	131	135	139	149	156
106	102	121	127	131	135	144	151
108	100	118	124	128	131	140	146

Note : For other steel grades, refer to Appendix 8.4.

Table 8.8(g) - Design strength p_c of compression members (cont'd)

Values of p_c in N/mm ² with $\lambda \geq 110$ for strut curve c							
λ	Steel grade and design strength (N/mm ²)						
	Q235	Q345/Q355	Q390	Q420	Q460	Q550	Q690
	215	305	345	375	410	520	630
110	98	115	120	124	127	136	141
112	96	112	117	120	124	131	137
114	93	109	114	117	120	127	132
116	91	106	111	114	117	124	128
118	89	104	108	111	114	120	124
120	87	101	105	108	110	117	121
122	85	98	102	105	107	113	117
124	84	96	100	102	104	110	114
126	82	93	97	99	102	107	110
128	80	91	95	97	99	104	107
130	78	89	92	94	96	101	104
135	74	84	87	88	90	94	97
140	70	79	81	83	85	88	91
145	66	74	77	78	80	83	85
150	63	70	72	74	75	78	80
155	60	66	68	69	71	73	75
160	57	63	65	66	67	69	71
165	54	60	61	62	63	65	67
170	52	57	58	59	60	62	63
175	49	54	55	56	57	59	60
180	47	51	52	53	54	56	57
185	45	49	50	50	51	53	54
190	43	46	47	48	49	50	51
195	41	44	45	46	46	48	49
200	39	42	43	44	44	46	46
210	36	39	40	40	40	42	42
220	33	36	36	37	37	38	39
230	31	33	33	34	34	35	36
240	29	30	31	31	31	32	33
250	27	28	29	29	29	30	30
260	25	26	27	27	27	28	28
270	23	24	25	25	25	26	26
280	22	23	23	23	24	24	24
290	20	21	22	22	22	22	23
300	19	20	20	20	21	21	21
310	18	19	19	19	19	20	20
320	17	18	18	18	18	19	19
330	16	17	17	17	17	17	18
340	15	16	16	16	16	16	17
350	14	15	15	15	15	16	16

Note : For other steel grades, refer to Appendix 8.4.

Table 8.8(h) - Design strength p_c of compression members

Values of p_c in N/mm ² with $\lambda < 110$ for strut curve d							
λ	Steel grade and design strength (N/mm ²)						
	Q235	Q345/Q355	Q390	Q420	Q460	Q550	Q690
	215	305	345	375	410	520	630
15	215	305	345	374	407	509	611
20	214	296	332	359	390	488	584
25	205	283	318	343	373	466	557
30	197	271	304	328	356	443	527
35	188	259	290	312	339	419	496
40	180	247	275	297	321	394	463
42	177	242	270	290	314	384	449
44	174	237	264	284	306	373	435
46	171	232	258	277	299	363	421
48	168	227	252	271	291	353	407
50	164	222	247	264	284	342	393
52	161	217	241	258	277	332	379
54	158	213	235	251	269	321	366
56	155	208	229	245	262	311	352
58	152	203	224	238	255	301	339
60	149	198	218	232	247	291	327
62	146	193	212	226	240	281	314
64	143	189	207	219	233	272	302
66	140	184	201	213	226	262	291
68	137	179	196	207	220	253	279
70	134	175	190	201	213	244	269
72	132	170	185	195	207	236	258
74	129	166	180	190	200	228	249
76	126	162	175	184	194	220	239
78	123	157	170	179	188	212	230
80	121	153	165	174	182	205	222
82	118	149	161	169	177	198	214
84	115	145	156	164	171	191	206
86	113	142	152	159	166	185	198
88	110	138	148	154	161	179	191
90	108	134	144	150	156	173	185
92	105	131	139	145	152	167	178
94	103	127	136	141	147	162	172
96	101	124	132	137	143	156	166
98	99	121	128	133	138	151	161
100	96	117	125	129	134	147	155
102	94	114	121	126	131	142	150
104	92	111	118	122	127	138	145
106	90	109	115	119	123	134	141
108	88	106	112	116	120	130	136

Note : For other steel grades, refer to Appendix 8.4.

Table 8.8(h) - Design strength p_c of compression members (cont'd)

Values of p_c in N/mm ² with $\lambda \geq 110$ for strut curve d							
λ	Steel grade and design strength (N/mm ²)						
	Q235	Q345/Q355	Q390	Q420	Q460	Q550	Q690
	215	305	345	375	410	550	690
110	86	103	109	113	116	126	132
112	84	101	106	110	113	122	128
114	82	98	103	107	110	118	124
116	81	96	101	104	107	115	121
118	79	93	98	101	104	112	117
120	77	91	95	98	101	109	114
122	76	89	93	96	99	106	110
124	74	87	91	93	96	103	107
126	72	85	89	91	94	100	104
128	71	83	86	89	91	97	101
130	69	81	84	87	89	95	99
135	66	76	79	81	84	89	92
140	62	72	75	77	79	83	86
145	59	68	71	72	74	78	81
150	56	64	67	68	70	74	76
155	54	61	63	65	66	69	72
160	51	58	60	61	62	66	68
165	49	55	57	58	59	62	64
170	47	52	54	55	56	59	61
175	45	50	51	52	53	56	57
180	43	47	49	50	51	53	54
185	41	45	47	47	48	50	52
190	39	43	44	45	46	48	49
195	37	41	42	43	44	46	47
200	36	40	41	41	42	44	45
210	33	36	37	38	38	40	41
220	31	33	34	35	35	37	37
230	28	31	32	32	33	34	34
240	26	29	29	30	30	31	32
250	25	27	27	28	28	29	29
260	23	25	25	26	26	27	27
270	22	23	24	24	24	25	25
280	20	22	22	22	23	23	24
290	19	20	21	21	21	22	22
300	18	19	19	20	20	20	21
310	17	18	18	18	19	19	19
320	16	17	17	17	18	18	18
330	15	16	16	16	17	17	17
340	14	15	15	16	16	16	16
350	14	14	15	15	15	15	15

Note : For other steel grades, refer to Appendix 8.4.

8.7.7 Eccentric connections

The effect of eccentric connections should be considered explicitly using the formulae for combined loads given in clause 8.9. Angles, channels and T-sections can also be designed using clause 8.7.9.

8.7.8 Simple construction

Pattern loads need not be considered in the design of simple structures as defined in clause 6.1. For column design, all beams are assumed fully loaded and simply supported on columns.

The nominal moment on columns due to simply supported beams should be calculated as follows:

- (a) For beams resting on a cap plate, the reaction should be taken as acting on the face of the column or edge of the packing towards the centre of the beam packing used.
- (b) For a roof truss resting on a cap plate, eccentricity can be neglected if the centre of reaction is at the centre of the column.
- (c) For beams resting on the face of steel columns, the reaction position should be taken as the larger of 100 mm from the column face or at the centre of the stiff bearing length.
- (d) For other cases not covered above, the actual eccentricities should be used.

In multi-storey buildings where columns are connected rigidly by splices, the net moment at any level should be distributed among members in proportion to the column stiffness or to their I/L ratios.

All equivalent moment factors in columns should be taken as unity. The column should be checked against the combined load condition using clause 8.9, with the effective length determined from clause 6.6.3 and taking the effective slenderness for lateral-torsional buckling λ_{LT} as,

$$\lambda_{LT} = \frac{0.5L}{r_y} \quad (8.75)$$

where

L is the length of the column between lateral supports or the storey height; and
 r_y is the radius of gyration about the minor axis.

8.7.9 Effective length of sections in triangulated structures and trusses

Angles, channels and T-sections are normally connected eccentrically and with different degrees of connection stiffness by welding or by one, two or more bolts. Buckling curve "c" in Table 8.7 should be used and the effective lengths of the sections must be carefully determined as follows or by a rational analysis such as a second-order analysis. The use of the following formulae is based on the assumption that the two ends of the members are effectively restrained against translational movement.

For out-of-plane buckling of chord members, the effective length L_E can be taken as the distance between lateral restraints unless other values can be justified by a buckling or second-order analysis. For chord members and out-of-plane buckling of web members, the effective length L_E is taken as the member length unless a smaller value can be justified by a buckling or second-order analysis.

For web members, buckling about principal axes and axes parallel to the legs should be considered. For angle sections connected by two or more bolts, the slenderness ratio should be calculated from the following:

For buckling about v-v axis, $\lambda_{eff,v} = 0.35 \times 85.8\varepsilon + 0.7\lambda_v$ or λ_v whichever is larger

For buckling about x-x axis, $\lambda_{eff,x} = 0.5 \times 85.8\varepsilon + 0.7\lambda_x$ or λ_x whichever is larger (8.76)

For buckling about y-y axis, $\lambda_{eff,y} = 0.5 \times 85.8\varepsilon + 0.7\lambda_y$ or λ_y whichever is larger

in which $\varepsilon = \sqrt{\frac{275}{p_y}}$ and λ_{eff} is the effective slenderness ratio. λ_v , λ_x and λ_y are respectively

the slenderness ratios about the minor v-axis and the x- and y-axes of the angle sections.

For a single bolt connection, 80% of the axial force compression resistance of the double bolt connection should be used.

For short members, the effect of load eccentricity should be considered analytically. Alternatively, the buckling strength of these sections can be designed as for other columns using the combined axial force and moment equation in clause 8.9 or by a second-order analysis allowing for eccentric connections and member imperfections such as using an equivalent member imperfection giving the same buckling strength curve “c” of Table 8.7.

Hollow sections used as members in trusses can be connected either by welding or by bolting. The in-plane effective length can be taken as the distance between connection nodes unless other values can be justified by a buckling or second-order analysis. The out-of-plane buckling resistance can be greatly enhanced by consideration of the torsional stiffness of hollow sections. This effect can be considered in a second-order or an advanced analysis. Curve “a” in Table 8.7 for hot rolled hollow sections or curve “c” for cold-formed hollow sections should be used for checking buckling strength.

8.8 TENSION MEMBERS UNDER COMBINED AXIAL FORCE AND MOMENTS

The cross-section capacity of a tension member under biaxial moment should be checked using the following equation:

$$\frac{F_t}{P_t} + \frac{M_x}{M_{cx}} + \frac{M_y}{M_{cy}} \leq 1 \quad (8.77)$$

in which,

F_t is the design axial tension at critical location;

M_{cx} is the moment capacity about the major axis from clause 8.2.2;

M_{cy} is the moment capacity about the minor axis from clause 8.2.2;

M_x is the design moment about the major axis at critical location;

M_y is the design moment about the minor axis at critical location;

P_t is the tension capacity given in clause 8.6.1.

Alternatively, for members of Class 1 plastic or Class 2 compact and symmetrical I and rectangular hollow cross-sections, a more exact check can be carried out by formulae in literature or a sectional strength analysis based on an assumption as follows. Area in web, and partly in flanges if web area is not sufficient to resist axial compression, is allocated to take the design axial compression and remaining area in webs and flanges is to resist moment in order to obtain the reduced moment capacities under axial compression. Under this analysis, Equation 8.77, with first term for axial compression ignored due to its inclusion in moment capacities, should be satisfied.

For more exact design of asymmetric and mono-symmetrical sections, maximum stresses due to moments about principal axes may not occur at the same location and the maximum stress of the whole cross section can be determined from the stresses computed from axial compression and individual moments with their respective moduli.

Tension members should be checked against lateral-torsional buckling by considering the design moment alone.

8.9 COMPRESSION MEMBERS UNDER COMBINED AXIAL FORCE AND MOMENTS

Compression members should be checked for cross-sectional capacity and member buckling resistance as follows:

8.9.1 Cross-section capacity

Except for Class 4 slender cross-sections, the cross-section capacity can be checked as,

$$\frac{F_c}{A_g P_y} + \frac{M_x}{M_{cx}} + \frac{M_y}{M_{cy}} \leq 1 \quad (8.78)$$

in which M_x and M_y are the design moments about the x- and y-axes. M_{cx} and M_{cy} are the moment capacities about the x- and y-axes.

For Class 4 slender cross-sections, the effective area A_{eff} should be used in place of the gross sectional area.

Alternatively, for members of Class 1 plastic or Class 2 compact and symmetrical I and rectangular hollow cross-sections, a more exact check can be carried out by formulae in literature or the sectional strength analysis described in clause 8.8.

For more exact design of asymmetric and mono-symmetrical sections, clause 8.8 should be referred.

8.9.2 Member buckling resistance

For Class 4 slender section, the effective moduli $Z_{x,eff}$ and $Z_{y,eff}$ should be used in place of the elastic moduli Z_x and Z_y in the following cases. When using the P- Δ - δ analysis allowing for initial imperfection and beam buckling in clause 6.8.3 a check for member buckling resistance in this clause is not required.

The resistance of the member of a sway frame as defined in clause 6.3 can be checked using,

$$\frac{F_c}{P_c} + \frac{m_x \bar{M}_x}{M_{cx}} + \frac{m_y \bar{M}_y}{M_{cy}} \leq 1 \quad (8.79)$$

$$\frac{F_c}{P_c} + \frac{m_x M_x}{M_{cx}} + \frac{m_y M_y}{M_{cy}} \leq 1 \quad (8.80)$$

$$\frac{F_c}{P_{cy}} + \frac{m_{LT} M_{LT}}{M_b} + \frac{m_y \bar{M}_y}{M_{cy}} \leq 1 \quad (8.81)$$

in which,

F_c is the design axial compression at the critical location;

M_b is the buckling resistance moment in clause 8.3.5.2;

M_x is the maximum design moment amplified for the P- Δ - δ effect about the major x-axis (see below);

M_y is the maximum design moment amplified for the P- Δ - δ effect about the minor y-axis (see below);

\bar{M}_x is the maximum first-order linear design moment about the major x-axis;

\bar{M}_y is the maximum first-order linear design moment about the minor y-axis;

M_{LT} is the maximum design moment amplified for the P- Δ - δ effect about major x-axis governing M_b (see below);

\bar{P}_c is the smaller of the axial force resistance of the column about x- and y-axis under non-sway mode and determined from a second-order analysis or taking member length as the effective length.

The effects of moment amplification are automatically considered in a second-order P-Δ-δ analysis. Alternatively, λ_{cr} can be found by an elastic buckling analysis or by Equation 6.1 and used to multiply the maximum moment by the following amplification factor.

$$\frac{\lambda_{cr}}{\lambda_{cr} - 1} = \text{larger of } \frac{1}{1 - \frac{F_v \delta_N}{F_N h}} \text{ and } \frac{1}{1 - \frac{F_c L_E^2}{\pi^2 EI}} \quad (8.82)$$

- M_{cx} is the elastic moment capacity $p_y Z_x$ about the major principal x-axis;
- M_{cy} is the elastic moment capacity $p_x Z_y$ about the minor principal y-axis;
- m_x is the equivalent uniform moment factor for flexural buckling about the major axis in Table 8.9;
- m_y is the equivalent uniform moment factor for flexural buckling about the minor axis in Table 8.9;
- m_{LT} is the equivalent moment factor for lateral-flexural buckling (see Table 8.4);
- P_{cx} is the compression resistance under sway mode and about the x-axis using clause 8.7.5;
- P_{cy} is the compression resistance under sway mode and about the y-axis using clause 8.7.5;
- P_c is the smaller of P_{cx} and P_{cy} .

For non-sway frames defined in clause 6.3, non-sway axial force resistance can be used for the computation of P_{cx} and P_{cy} and checking using Equations 8.80 and 8.81 is adequate. For more exact analysis, \bar{P}_c in equation 8.80 can be replaced by P_c using the computed effective length. The P-δ amplification factor below should be used for non-sway frames.

$$\frac{1}{1 - \frac{F_c L_E^2}{\pi^2 EI}} \quad (8.83)$$

The design moment for connections in sway and ultra-sway frames must include the P-Δ effect.

When second-order P-Δ-δ analysis is used, the amplification is considered in the analysis and amplification at design stage is not needed.

Table 8.9 - Moment equivalent factor m for flexural buckling

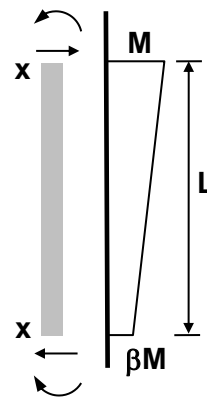
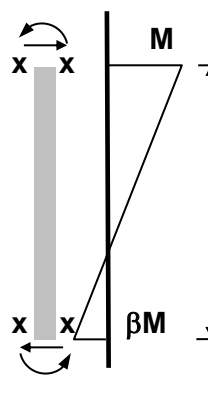
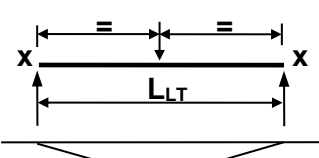
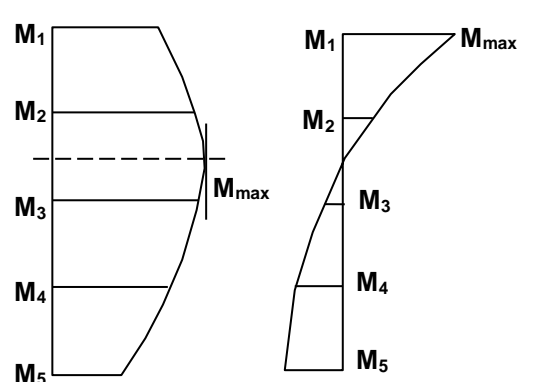
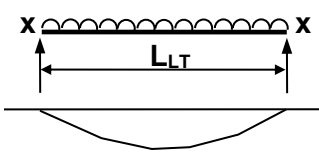
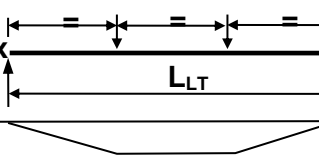
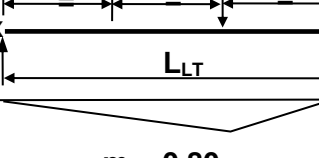
Segment with end moment only (value of m from the formula of general case)		β	m
<p>β positive</p>  <p>X - lateral restraint</p>	<p>β negative</p> 	1.0	1.00
		0.9	0.96
		0.8	0.92
		0.7	0.88
		0.6	0.84
		0.5	0.80
		0.4	0.76
		0.3	0.72
		0.2	0.68
		0.1	0.64
		0.0	0.60
		-0.1	0.58
		-0.2	0.56
		-0.3	0.54
-0.4	0.52		
-0.5	0.50		
-0.6	0.48		
-0.7	0.46		
-0.8	0.44		
-0.9	0.42		
-1.0	0.40		
Segment between intermediate lateral restraints			
Specific cases	General case		
 <p>$m = 0.90$</p>	 $m = 0.2 + \frac{0.1M_2 + 0.6M_3 + 0.1M_4}{M_{\max}} \text{ but } m \geq \frac{0.8M_{24}}{M_{\max}}$ <p>The moment M_2 and M_4 are the values at the quarter points and the moment M_3 is the value at mid-length.</p> <p>If M_2, M_3 and M_4 all lie on the same side of the axis, their values are all taken as positive. If they lie both sides of the axis, the side leading to the larger value of m is taken as the positive side.</p> <p>The values of M_{\max} and M_{24} are always taken as positive. M_{\max} is the maximum moment in the segment and M_{24} is the maximum moment in the central half of the segment.</p>		
 <p>$m = 0.95$</p>			
 <p>$m = 0.95$</p>			
 <p>$m = 0.80$</p>			

8.9.3 Member buckling resistance – (Alternative to 8.9.2)

Members which are subjected to combined bending and axial compression should satisfy:

$$\frac{F_c}{A_g p_{cx}} + k_{xx} \frac{M_x}{M_b} + k_{xy} \frac{M_y}{M_{cy}} \leq 1 \quad (8.82a)$$

$$\frac{F_c}{A_g p_{cy}} + k_{yx} \frac{M_x}{M_b} + k_{yy} \frac{M_y}{M_{cy}} \leq 1 \quad (8.82b)$$

where F_c , M_x and M_y are the design values of the compression force and the maximum moments about the major (x-x) axis and the minor (y-y) axis along the member, respectively

M_b is the buckling resistance moment in clause 8.3.5.2

M_{cy} is the moment capacity about the minor axis from clause 8.2.2

p_{cx}, p_{cy} are the axial strength under column buckling about the major (x-x) axis, and the minor (y-y) axis

$k_{xx}, k_{xy}, k_{yx}, k_{yy}$ are the interaction factors given in Table 8.10.

Refer to Table 8.10 for members not susceptible to torsional deformations, or to Table 8.11 for members susceptible to torsional deformations.

Table 8.10 Interaction factors for combined axial compression and bending

Interaction factors	Type of sections	Design assumptions	
		Elastic cross-sectional properties Class 3, Effective cross-sectional properties Class 4	Plastic cross-sectional properties Class 1, Class 2
k_{xx}	I-sections RHS	$C_{mx} \left(1 + 0.6 \bar{\lambda}_x \frac{F_c}{P_{cx}} \right)$ $\leq C_{mx} \left(1 + 0.6 \frac{F_c}{P_{cx}} \right)$	$C_{mx} \left(1 + (\bar{\lambda}_x - 0.2) \frac{F_c}{P_{cx}} \right)$ $\leq C_{mx} \left(1 + 0.8 \frac{F_c}{P_{cx}} \right)$
k_{xy}	I-sections RHS	k_{yy}	$0.6k_{yy}$
k_{yx}	I-sections RHS	$0.8k_{xx}$	$0.6k_{xx}$
k_{yy}	I-sections	$C_{my} \left(1 + 0.6 \bar{\lambda}_y \frac{F_c}{P_{cy}} \right)$ $\leq C_{my} \left(1 + 0.6 \frac{F_c}{P_{cy}} \right)$	$C_{my} \left(1 + (2\bar{\lambda}_y - 0.6) \frac{F_c}{P_{cy}} \right)$ $\leq C_{my} \left(1 + 1.4 \frac{F_c}{P_{cy}} \right)$
	RHS		$C_{my} \left(1 + (\bar{\lambda}_y - 0.2) \frac{F_c}{P_{cy}} \right)$ $\leq C_{my} \left(1 + 0.8 \frac{F_c}{P_{cy}} \right)$
For I- and H-sections and rectangular hollow sections under axial compression and uniaxial bending M_x , the coefficient k_{yx} may be $k_{yx} = 0$.			

Note:

$$\bar{\lambda}_x = \frac{\lambda_x}{\pi \sqrt{\frac{E}{P_y}}}$$

$$\bar{\lambda}_y = \frac{\lambda_y}{\pi \sqrt{\frac{E}{P_y}}}$$

Table 8.11 Interaction factors k_{ij} for members susceptible to torsional deformations

Interaction factors	Design assumptions	
	Elastic cross-sectional properties Class 3, Effective cross-sectional properties Class 4	Plastic cross-sectional properties Class 1, Class 2
k_{xx}	k_{yy} from Table 8.10)	k_{yy} from Table 8.10
k_{xy}	k_{yz} from Table 8.10)	k_{yz} from Table 8.10
k_{yx}	$\left[1 - \frac{0.05\bar{\lambda}_y}{(C_{mLT} - 0.25) P_{cy}} \frac{F_c}{P_{cy}} \right]$ $\leq \left[1 - \frac{0.05}{(C_{mLT} - 0.25) P_{cy}} \frac{F_c}{P_{cy}} \right]$	$\left[1 - \frac{0.1\bar{\lambda}_y}{(C_{mLT} - 0.25) P_{cy}} \frac{F_c}{P_{cy}} \right]$ $\geq \left[1 - \frac{0.1}{(C_{mLT} - 0.25) P_{cy}} \frac{F_c}{P_{cy}} \right]$ <p style="text-align: center;">for $\bar{\lambda}_y < 0.4$:</p> $k_{zy} = 0.6 + \bar{\lambda}_y \leq 1 - \frac{0.1\bar{\lambda}_y}{(C_{mLT} - 0.25) P_{cy}} \frac{F_c}{P_{cy}}$
k_{yy}	k_{yy} from Table 8.10	k_{yy} from Table 8.10

Table 8.12 Equivalent uniform moment factors, C_m in Tables 8.10 and 8.11

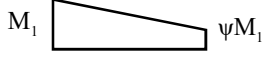
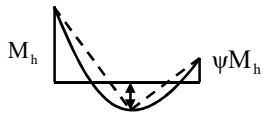
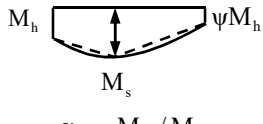
Moment diagram	Range		C_{mx} and C_{my} and C_{mLT}													
			Uniform loading	Concentrated load												
	$-1 \leq \psi \leq 1$		$0.6 + 0.4\psi \geq 0.4$													
 $\alpha_h = M_s / M_h$	$0 \leq \alpha_s \leq 1$	$-1 \leq \psi \leq 1$	$0.2 + 0.8\alpha_s \geq 0.4$	$0.2 + 0.8\alpha_s \geq 0.4$												
	$-1 \leq \alpha_s \leq 0$	$0 \leq \psi \leq 1$	$0.1 - 0.8\alpha_s \geq 0.4$	$-0.8\alpha_s \geq 0.4$												
		$-1 \leq \psi \leq 0$	$0.1(1 - \psi) - 0.8\alpha_s \geq 0.4$	$0.2(-\psi) - 0.8\alpha_s \geq 0.4$												
 $\alpha_h = M_h / M_s$	$0 \leq \alpha_h \leq 1$	$-1 \leq \psi \leq 1$	$0.95 + 0.05\alpha_h$	$0.90 + 0.10\alpha_h$												
	$-1 \leq \alpha_h \leq 0$	$0 \leq \psi \leq 1$	$0.95 + 0.05\alpha_h$	$0.90 + 0.10\alpha_h$												
		$-1 \leq \psi \leq 0$	$0.95 + 0.05\alpha_h(1 + 2\psi)$	$0.90 + 0.10\alpha_h(1 + 2\psi)$												
For members with sway buckling mode the equivalent uniform moment factor should be taken $C_{mx} = 0.9$ or $C_{my} = 0.9$ respectively.																
C_{mx} , C_{my} and C_{mLT} should be obtained according to the bending moment diagram between the relevant braced points as follows: <table border="1" style="width: 100%; border-collapse: collapse;"> <thead> <tr> <th>Moment factor</th> <th>Bending axis</th> <th>Points braced in direction</th> </tr> </thead> <tbody> <tr> <td style="text-align: center;">C_{mx}</td> <td style="text-align: center;">x-x</td> <td style="text-align: center;">y-y</td> </tr> <tr> <td style="text-align: center;">C_{my}</td> <td style="text-align: center;">y-y</td> <td style="text-align: center;">x-x</td> </tr> <tr> <td style="text-align: center;">C_{mLT}</td> <td style="text-align: center;">x-x</td> <td style="text-align: center;">x-x</td> </tr> </tbody> </table>					Moment factor	Bending axis	Points braced in direction	C_{mx}	x-x	y-y	C_{my}	y-y	x-x	C_{mLT}	x-x	x-x
Moment factor	Bending axis	Points braced in direction														
C_{mx}	x-x	y-y														
C_{my}	y-y	x-x														
C_{mLT}	x-x	x-x														

8.10 TORSIONAL AND FLEXURAL-TORSIONAL BUCKLING OF COMPRESSION MEMBERS

Single angle, double angle, tee sections and cruciform compression members with small thickness-to-length ratios may buckle in a torsional or a flexural-torsional mode. A check should be carried out by considering the interaction of torsional buckling mode with the flexural buckling mode about the principal axes. Design checks should be carried out as given in clause 11.5.4.

8.11 PORTAL FRAMES

8.11.1 General

Either elastic or plastic analysis may be adopted for the design of single-storey frames with rigid moment-resisting joints, see clauses 6.5, 6.6, 6.7, and 6.8. All load combinations should be covered. For the load case involving the gravity load only, notional horizontal forces should be applied to check the adequacy of in-plane stability. The out-of-plane stability of all frame members under all load cases should be ensured by the provision of appropriate lateral and torsional restraints.

8.11.2 Elastic design

In the elastic analysis of portal frames, the members should be designed in accordance with clauses 8.8 and 8.9. The out-of-plane stability should be checked considering the interaction of the torsional buckling mode with the flexural buckling mode about the principal axes, see clause 8.3.

For non-sway frames and independently braced frames, the in-plane member buckling resistances should be checked using clause 8.9.

In global elastic analysis where $P-\Delta$ effects have not been calculated, the ultimate design loads must be multiplied by the required load factor λ_r obtained from clause 8.11.4 to check against the member resistance.

8.11.3 Plastic design

Plastic analysis can be used when static loading, rather than fatigue, is the main design concern. The material should be Class 1 to ensure the development of plastic hinge and redistribution of moment.

The plastic load factor obtained from a first-order global analysis with ultimate design loads should satisfy:

$$\lambda_p \geq \lambda_r \quad (8.84)$$

Member resistance is checked by multiplying ultimate design loads by λ_r .

8.11.4 In-plane stability

8.11.4.1 General

The in-plane stability of portal frames under each load combination must be checked when the member sizes have been determined. One of the following methods should be used except for the case of tied portal frames:

- the sway-check method plus snap through stability check in clause 8.11.4.2.
- the amplified moments method given in clause 8.11.4.3.
- a second order analysis, see clause 8.11.4.4.

Tied portal frames should be checked as recommended in clause 8.11.4.5.

8.11.4.2 Sway-check method plus snap through stability

8.11.4.2.1 General

For untied portal frames which satisfying the following conditions, simplified sway check method may be used:

- a) The span L does not exceed 5 times the mean height h of the columns;
 b) The height h_r of the ridge above the apex does not exceed 0.25 times the span L ;
 c) If the portal frame is asymmetric, h_r should satisfy the criterion $\left(\frac{h_r}{s_a}\right)^2 + \left(\frac{h_r}{s_b}\right)^2 \leq 5$,
 where s_a and s_b are the horizontal distance from the apex to columns, see Figure 8.5.

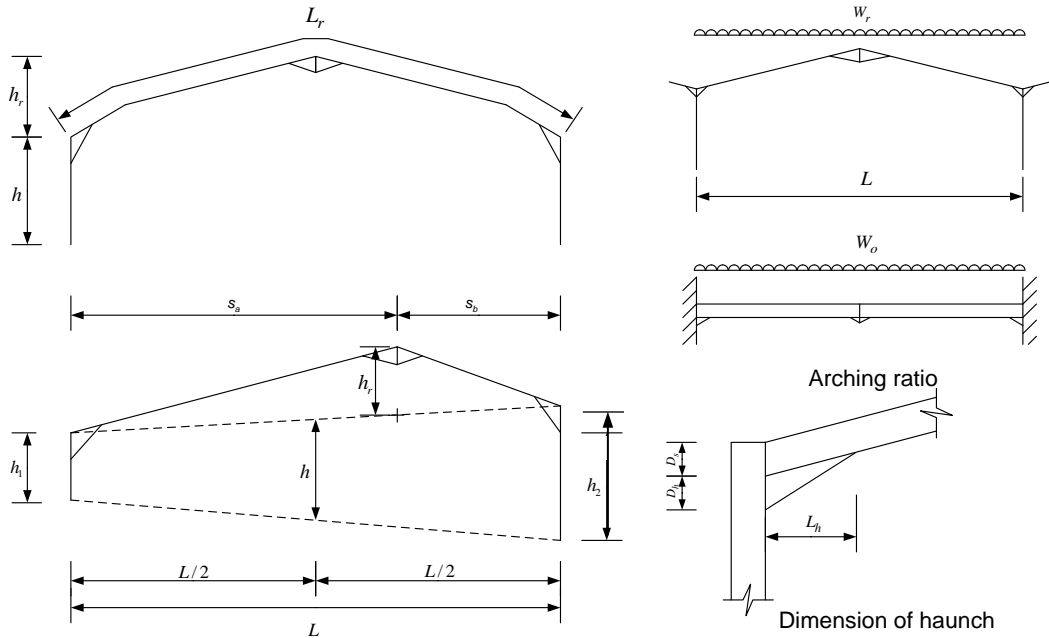

Figure 8.5 - Geometry of portal frames

When these geometric limitations are satisfied, linear elastic analysis should be used to determine the deflection at the top of the columns caused by a notional lateral force applied generally at the top of the columns in the plane of the frame. The notional horizontal force is calculated in accordance with clause 2.5.8. If significant proportions of vertical loads are applied at levels below the top of the columns, the corresponding notional horizontal forces should be applied at the same levels where the vertical loads are applied.

8.11.4.2.2 Gravity loads

The gravity load cases include load combination 1 in clause 4.3 and load combination 1 in Table 13.3 of clause 13.7.3 where vertical crane loads are present. Any stiffening effects provided by cladding, roof plan bracing, and roof sheeting should be ignored in the calculation of notional horizontal deflection. If the calculated deflection δ_i is less than $h_i/1000$ then the required plastic collapse load factor λ_r may be taken as 1.0.

A simplified formula may be used to check the stability if there are no valley beams, crane gantries or significant concentrated load larger than those from purlins and in cases where the deflections are otherwise difficult to determine:

$$\frac{L_b}{D} \leq \frac{44L}{\Omega h} \left(\frac{\rho}{4 + \rho L_r/L} \right) \left(\frac{275}{\rho_{yr}} \right) \quad (8.85)$$

in which

$$L_b = L - \left(\frac{2D_h}{D_s + D_h} \right) L_h \quad (8.86)$$

$$\rho = \left(\frac{2I_c}{I_r} \right) \left(\frac{L}{h} \right) \quad \text{for a single bay frame;} \quad (8.87)$$

$$\rho = \left(\frac{I_c}{I_r} \right) \left(\frac{L}{h} \right) \quad \text{for a multi-bay frame;} \quad (8.88)$$

and Ω is the arching ratio, given by:

$$\Omega = W_r / W_o \quad (8.89)$$

where

D is the cross-section depth of the rafter;

D_h is the additional depth of the haunch, see Figure 8.5;

D_s is the depth of the rafter, allowing for its slope, see Figure 8.5;

h is the mean column height;

I_c is the in-plane second moment of area of the column (taken as zero if the column is not rigidly connected to the rafter, or if the rafter is supported on a valley beam);

I_r is the in-plane second moment of area of the rafter;

L is the span of the bay;

L_b is effective span of the bay;

L_h is the length of a haunch;

L_r is the total developed length of the rafters, see Figure 8.5;

p_{yr} is the design strength of the rafters in N/mm²;

W_o is the value of W_r for plastic failure of the rafters as a fixed-ended beam of span L ;

W_r is the total factored vertical load on the rafters of the bay;

If the two columns or the two rafters of a bay differ, the mean value of I_c/I_r should be used.

If the haunches at each side of the bay are different, the mean value of L_b should be used.

8.11.4.2.3 Horizontal loads

When checking load combination 2 and load combination 3 of clause 4.3, where wind loads and other significant horizontal loads are present, the stiffening effects provided by cladding, plan bracing and roof-sheeting should be taken into account to calculate the notional horizontal deflections δ_i .

The value of λ_r for load cases involving horizontal loads may be determined from the following simple rules provided that the frame is stable under gravity loading, i.e. the $h/1000$ criteria or the formula is satisfied for gravity loading. (Equation 6.9 in clause 6.6.2)

$$\lambda_r = \frac{\lambda_{sc}}{(\lambda_{sc} - 1)} \quad (8.90)$$

in which λ_{sc} is the smallest value for each column determined by equation 6.1 in clause 6.3.2.2.

If $\lambda_{sc} < 5$, second order analysis should be used.

If there are no valley beams, crane gantries or significant concentrated loads larger than those from purlins, and where the deflections are difficult to determine a simplified formula may be used to check the stability:

$$\frac{L_b}{D} \leq \frac{220DL}{\Omega h L_b} \left(\frac{\rho}{4 + \rho L_r/L} \right) \left(\frac{275}{p_{yr}} \right) \quad (8.91)$$

If the axial forces are tensile in all rafters and columns under wind loads, the required load factor λ_r should be taken as 1.0.

8.11.4.2.4 Snap-through stability

For internal bays of multi-bay frames the possibility of snap through stability should be considered and checked by the following formula:

$$\frac{L_b}{D} \leq \frac{22(4 + L/h)}{4(\Omega - 1)} \left(1 + \frac{I_c}{I_r} \right) \left(\frac{275}{p_{yr}} \right) \tan 2\theta \quad (8.92)$$

where θ is the slope of the rafters for a symmetrical frame and $\tan^{-1}(2h_r/L)$ for asymmetric frames.

8.11.4.3 Amplified moment method

When the geometric limitations of clause 6.4.2 to use the sway check method are not met, the amplified moment method may be adopted. The elastic critical load factor λ_{cr} should be calculated from the eigenvalue analysis instead of using the approximate formula (Equation 6.1) in clause 6.3.2.2. If λ_{cr} for the relevant load case can be calculated, and is not less than 5, the required load factor can be determined.

If $\lambda_{cr} \geq 10$ then λ_r may be taken as 1.0;

If $10 > \lambda_{cr} \geq 5$ then λ_r may be calculated by

$$\lambda_r = \frac{0.9\lambda_{cr}}{(\lambda_{cr} - 1)} \quad (8.93)$$

If $\lambda_{cr} < 5$ then the amplified moment method should not be used as the lateral stiffness of the portal frame is too low. In such a case the lowest elastic critical load factor is generally obtained using elastic critical load analysis.

8.11.4.4 Second order analysis

Where the above methods are not appropriate, a full second order analysis, either elastic or elastic-plastic, should be carried out. In this case, the required load factor λ_r should be taken as 1.0.

8.11.4.5 Tied portals

Tied portals should be treated with extreme caution to ensure stability of the slender rafters that can result from this method of design. A full second order elastic or elastic-plastic analysis should be carried out. Tied portals may usually have shallow rafters. The axial forces in rafters increase inversely proportional to the actual slopes of the rafters. In addition, the curvature of the deformed rafter will increase apex drop. The analysis software routines adopted should be able to account for such nonlinearities.

8.11.5 Out-of-plane stability

8.11.5.1 General

The out-of-plane stability of the frame should be ensured by making the frame effectively non-sway out-of-plane. This will imply the use of bracing or very stiff portal frame. The out-of-plane stability of all frame members should be ensured by the provision of appropriate lateral and torsional restraints under all load cases.

8.11.5.2 Torsional restraints

Torsional restraint prevents twisting of the section. The most effective way is to provide lateral restraints to both flanges of a section. The use of a "fly" brace to provide torsional restraint is shown in Figure 8.6.

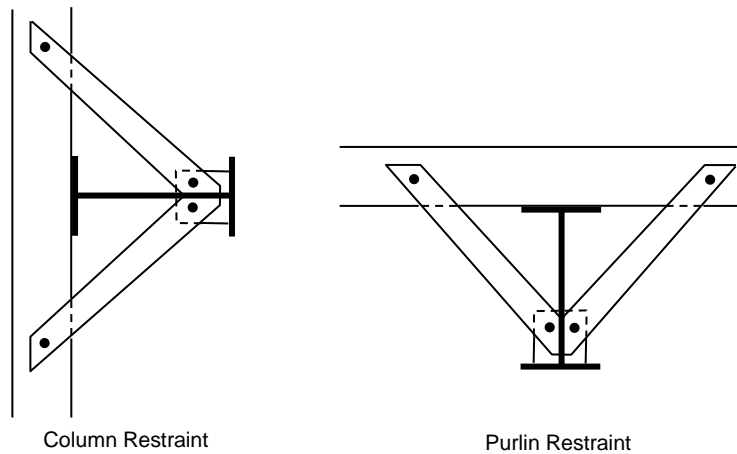

Figure 8.6 - Example of using fly brace for column and rafter

At the point of contraflexure in a portal frame rafter, the section may be assumed to be torsionally restrained by a virtual lateral restraint to the bottom flange if the purlins and their connections to the top flange of the rafter are capable of providing torsional restraint to the top flange of the rafter.

Torsional restraint of the top flange may be assumed to exist if the following conditions are satisfied:

- a) The rafter is an I-section with $D/B \geq 1.2$, where D is the depth and B is the flange width;
- b) For haunched rafters D_h is not greater than $2D$;
- c) Every length of purlin has at least two bolts in each purlin-to-rafter connection;
- d) The depth of the purlin section is not less than 0.25 times the depth D of the rafter.

Lateral restraint of the bottom flange should not be assumed at the point of contraflexure under other restraint conditions, unless a lateral restraint is actually provided at that point.

8.11.5.3 Location of torsional restraints

8.11.5.3.1 General

Torsional restraints should be provided in accordance with the following requirements:

- (1) All plastic hinges locations should be torsionally restrained at both flanges. Where it is not practical to do this at the hinge location, a restraint may be provided within a distance $D/2$ of the hinge location.
- (2) The distance between the plastic hinge and the next torsional restraint (restraint to both flanges) can be calculated by two methods:
 - a) A conservative method which does not allow for the shape of the moment diagram between the plastic hinge and the next torsional restraint.
 - b) An approximate method which allows for shape of the moment diagram.

The lateral restraints at both flanges and/or virtual restraints at bottom flange (see Figure 8.6) should extend up to or beyond the point of contraflexure.

8.11.5.3.2 Conservative method

The distance between a plastic hinge and the next torsional restraint L_m should not exceed L_u determined by:

$$L_u = \frac{38r_y}{\left[\frac{f_c}{130} + \left(\frac{x}{36} \right)^2 \left(\frac{p_y}{275} \right)^2 \right]^{1/2}} \quad (8.94)$$

where

f_c is the compressive stress (in N/mm²) due to axial force;

p_y is the design strength (in N/mm²);

r_y is the radius of gyration about the minor axis;

x is the torsional index, see Appendix 8.2.

If the member has unequal flanges the radius of gyration about the minor axis r_y should be taken as the lesser of the values for the compression flange(s).

8.11.5.3.3 Approximate method allowing for moment gradient

For I section members with uniform cross section with equal flanges and $D/B \geq 1.2$ where f_c does not exceed 80 N/mm²:

$$L_m = \phi L_u \quad (8.95)$$

In which case L_u is given in equation 8.94 of clause 8.11.5.3.2 and ϕ is given as following:

$$\text{For } 1 \geq \beta \geq \beta_u: \quad \phi = 1 \quad (8.96)$$

$$\text{For } \beta_u > \beta > 0: \quad \phi = 1 - (1 - K K_0)(\beta_u - \beta)/\beta_u \quad (8.97)$$

$$\text{For } 0 \geq \beta > -0.75: \quad \phi = K(K_0 - 4(1 - K_0)\beta/3) \quad (8.98)$$

$$\text{For } \beta \leq -0.75: \quad \phi = K \quad (8.99)$$

where β is the end moment ratio, and

For steel grade of design strength between 200 to 300 MPa,

$$\beta_u = 0.44 + \frac{x}{270} - \frac{f_c}{200} \quad (8.100)$$

For steel grade of design strength greater than 300 MPa and less than 460 MPa,

$$\beta_u = 0.47 + \frac{x}{270} - \frac{f_c}{250} \quad (8.101)$$

For other steel grades, P- Δ - δ and advanced analyses should be used.

Coefficient K_0 and K can be calculated as follows:

$$K_0 = (180 + x)/300 \quad (8.102)$$

$$\text{For } 20 \leq x \leq 30, \quad K = 2.3 + 0.03x - x f_c/3000 \quad (8.103)$$

$$\text{For } 30 < x \leq 50, \quad K = 0.8 + 0.08x - (x - 10) f_c/2000 \quad (8.104)$$

8.11.5.3.4 Segments with one flange restrained

Where one flange is restrained between torsional restraints (i.e. restraints to both flanges) the distance between torsional restraints may be increased provided that:

- adjacent to a plastic hinge location, the spacing of intermediate lateral restraints should not exceed L_m as given in clause 8.11.5.3.3; and
- the distance between the intermediate lateral restraints would be adequate if they were attached to the compression flange. Member buckling resistance should be checked in accordance with clause 8.9 or L_m from clause 8.11.5.3.3.

In addition to conditions a) and b), when the following conditions are satisfied, a simplified method may be used:

- The member is an I-section with $D/B \geq 1.2$;
- For haunched rafters $D_h \leq 2D_s$;
- For haunched segments the haunch flange is not smaller than the member flange;
- The steel grade of design strength between 200 to 460 MPa.

For other steel grades, P- Δ - δ elastic analysis or advanced analysis should be used.

The spacing L_y between restraints to the compression flange should not exceed the limiting spacing L_s given as follows:

For steel grade of design strength between 200 to 300 MPa,

$$L_s = \frac{620 r_y}{K_1 [72 - (100/x)^2]^{0.5}} \quad (8.105)$$

For steel grade of design strength greater than 300 MPa and less than 460 MPa,

$$L_s = \frac{645 r_y}{K_1 [94 - (100/x)^2]^{0.5}} \quad (8.106)$$

Where

r_y is the minor axis radius of the un-haunched rafter (is the minimum value of the radius of gyration within the length of the segment (at the top of the haunch));
 x is the maximum value of torsional index within the segment, see Appendix 8.2. Note that at the bottom of the haunch x can be approximated with D/T .

K_1 has the following value:

For an un-haunched segment $K_1 = 1.00$

For a haunch with $D_h/D_s = 1$ $K_1 = 1.25$

For a haunch with $D_h/D_s = 2$ $K_1 = 1.40$

For a haunch generally $K_1 = 1 + 0.25(D_h/D_s)^{2/3}$ (8.107)

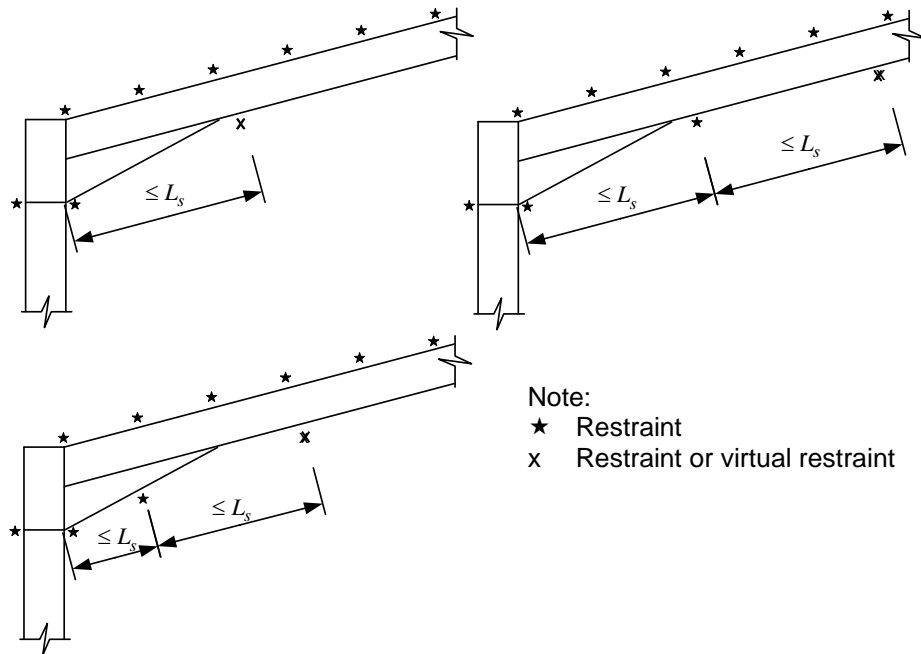

Figure 8.7 - Haunch restraints

8.12 LACED AND BATTENED STRUTS

Lighter structural elements can be fabricated to form laced and battened struts to increase their resistance. Laced columns normally have transverse members arranged in triangulated manner and battened columns have the transverse members placed perpendicular to the longitudinal axis of the compound columns.

8.12.1 Laced struts

A laced strut consisting of two or more main components may be designed using a second-order analysis with allowance for component and strut imperfections or as a single integral member if the following conditions are met:

- a) The main components should be effectively restrained against buckling by a lacing system of flats or sections.
- b) The lacing should comprise an effectively restrained system on each face and the lacing should not vary throughout the length of the member.
- c) Except for tie panels in f) below, double and single intersection lacing systems mutually opposed in direction on opposite sides of two main components should not be combined with members or diaphragms perpendicular to the longitudinal axis of the strut unless all forces resulting from deformation of the strut members are allowed for.
- d) Single lacing systems mutually opposed in direction on opposite sides of two main components should not be used unless the resulting torsional effects are allowed for.
- e) All lacings should be inclined at an angle between 40° and 70° to the axis of the member.
- f) Tie panels should be provided at the ends of the lacing systems, at points where the lacing is interrupted and at connections with other members. Tie panels may take the form of battens conforming to clause 8.12.2 below or cross braced panels of equivalent rigidity may be used. In either case, the tie panels should be designed to carry the loads for which the lacing system is designed.
- g) The slenderness λ_c of the main components about their minimum radius of gyration between consecutive points where the lacing is attached should not exceed 50. If the overall slenderness of the member is less than $1.4 \lambda_c$ the design should be based on a slenderness of $1.4\lambda_c$.
- h) The effective length of a lacing should be taken as the distance between the inner end welds or bolts for single intersection lacing and as 0.7 times of this distance for double intersection lacing connected by welds or bolts at the intersection. The slenderness of a lacing should not exceed 180.
- i) The lacings and their connections should be designed to carry forces induced by a transverse shear at any point in the length of the member equal to 2.5% of the axial force in the member, divided equally amongst all transverse lacing systems in parallel planes. For members carrying moments due to eccentricity of loading, applied end moments or lateral loading, the lacing should be proportioned to resist the shear due to bending in addition to 2.5% of the axial force.

8.12.2 Battened struts

A battened strut consisting of two or more main components may be designed using a second-order analysis with allowance for component and strut imperfections or as a single integral member if the following conditions are met.

- a) The main component should be effectively restrained against buckling by a system of battens consisting of plates or sections, so connected to the main components to form an effectively rigid-jointed frame.
- b) Battens should be positioned opposite each other in each plane at ends of the members and at points where it is laterally restrained. Intermediate battens should

be positioned opposite each other and be spaced and proportioned uniformly throughout the length of a member.

- c) The slenderness λ_c of a main component based on minimum radius of gyration between end welds or end bolts of adjacent battens should not exceed 50. The slenderness λ_b of the battened strut about the axis perpendicular to the plane of the battens should be calculated as,

$$\lambda_b = \sqrt{\lambda_m^2 + \lambda_c^2} \quad (8.108)$$

in which λ_m is the ratio $\frac{L_E}{r}$ of the whole member about that axis.

- d) If λ_b is less than $1.4\lambda_c$, the design should be based on a slenderness of $1.4\lambda_c$.
- e) The thickness of the plate battens should not be less than 1/50 of the minimum distance between welds or bolts. The slenderness of sections used as battens should not exceed 180. The width of an end batten along the axis of the main components should not be less than the distance between centroids of the main members and not less than half this distance for intermediate battens. Further, the width of any batten should be not less than twice the width of the narrow main component.
- f) The battens and their connections and the main components should be designed to carry the forces and moments induced by transverse shear at any point in the length of the member equal to 2.5% of the axial force in the member. For members carrying moments due to eccentricity of loading, applied end moments or lateral loads, the battens should be proportioned to resist the shear due to bending in addition to 2.5% of the axial force.

Appendix 8.1

The bending buckling strength p_b for resistance to lateral-torsional buckling should be taken as the smaller root of the following equation.

$$(p_E - p_b)(p_y - p_b) = \eta_{LT} p_E p_b \quad (\text{A8.1})$$

Hence

$$p_b = \frac{p_E p_y}{\phi_{LT} + \sqrt{(\phi_{LT}^2 - p_E p_y)}} \quad (\text{A8.2})$$

where,

$$p_E = \frac{\pi^2 E}{\lambda_{LT}^2} \quad (\text{A8.3})$$

$$\phi_{LT} = \frac{p_y + (\eta_{LT} + 1)p_E}{2} \quad (\text{A8.4})$$

p_y is the design strength,

λ_{LT} is the equivalent slenderness

η_{LT} is the Perry factor taken as follows.

For rolled sections,

$$\eta_{LT} = \alpha_{LT}(\lambda_{LT} - \lambda_{L0})/1000; \eta_{LT} \geq 0; \quad (\text{A8.5})$$

For welded sections,

$$\text{For } \lambda_{LT} \leq \lambda_{L0}; \eta_{LT} = 0 \quad (\text{A8.6})$$

$$\text{For } \lambda_{L0} < \lambda_{LT} \leq 2\lambda_{L0}; \eta_{LT} = \frac{2\alpha_{LT}(\lambda_{LT} - \lambda_{L0})}{1000} \quad (\text{A8.7})$$

$$\text{For } 2\lambda_{L0} < \lambda_{LT} \leq 3\lambda_{L0}; \eta_{LT} = \frac{2\alpha_{LT}\lambda_{L0}}{1000} \quad (\text{A8.8})$$

$$\text{For } \lambda_{LT} > 3\lambda_{L0}; \eta_{LT} = \frac{\alpha_{LT}(\lambda_{LT} - \lambda_{L0})}{1000} \quad (\text{A8.9})$$

$$\lambda_{L0} = 0.4 \sqrt{\frac{\pi^2 E}{p_y}} \quad (\text{A8.10})$$

$$\alpha_{LT} = 7.0 \quad (\text{A8.11})$$

α_{LT} is applicable to all steel grades at sources.

Appendix 8.2

For uniform I, H and channel sections with equal flanges, the equivalent slenderness λ_{LT} should be obtained as follows.

$$\lambda_{LT} = uv\lambda\sqrt{\beta_w} \quad (\text{A8.12})$$

where

$$\lambda = \frac{L_E}{r_y} \quad (\text{A8.13})$$

L_E is the effective length for lateral-torsional buckling from clause 8.3.4

r_y is the radius of gyration about the minor y-axis

u is the buckling parameter

$$= \left(\frac{4S_x^2\gamma}{A^2h_s^2} \right)^{0.25} \quad \text{for equal flanged I and H sections} \quad (\text{A8.14})$$

$$= \left(\frac{I_y S_x^2 \gamma}{A^2 H} \right)^{0.25} \quad \text{for equal flanged channels} \quad (\text{A8.15})$$

v is the slenderness factor given by,

$$\frac{1}{(1+0.05(\lambda/x)^2)^{0.25}} \quad (\text{A8.16})$$

x is the torsional index

$$= 0.566h_s\sqrt{\frac{A}{J}} \quad \text{for equal flanged I and H sections} \quad (\text{A8.17})$$

$$= 1.132\sqrt{\frac{AH}{I_y J}} \quad \text{for equal flanged channels} \quad (\text{A8.18})$$

Alternatively, u and x in Equations A8.14, A8.15, A8.17 and A8.18 can be obtained for rolled and welded I, H or channel sections with equal flanges as,

$$x = \frac{D}{T} \quad \text{and } u=0.9 \quad \text{for rolled I, H or channel sections with equal flanges.}$$

$$x = \frac{D}{T} \quad \text{and } u=1.0 \quad \text{for welded I, H or channel sections with equal flanges.}$$

D is the depth of the section

H is the warping constant for equal flanged channel sections

$$= \frac{h_s^2(B-t/2)^3 T}{12} - \frac{2h_s t + 3(B-t/2)T}{h_s t + 6(B-t/2)T} \quad (\text{A8.19})$$

h_s is the distance between shear centres of flanges

J is the torsional constant

S_x is the plastic modulus about the major axis

t is the web thickness

T is the flange thickness

$$\gamma = 1 - \frac{I_y}{I_x} \quad (\text{A8.20})$$

β_w is the ratio defined in Equations 8.28 and 8.29.

Buckling strength of other sections should be determined by a recognized buckling analysis.

Appendix 8.3

The shear buckling strength of web in an I-section beams or plate girders may be obtained as follows:

For welded I-section,

$$\text{For } \lambda_w \leq 0.8, \quad q_w = p_v \quad (\text{A8.21})$$

$$\text{For } 0.8 < \lambda_w < 1.25, \quad q_w = \left(\frac{13.48 - 5.6\lambda_w}{9} \right) p_v \quad (\text{A8.22})$$

$$\text{For } \lambda_w \geq 1.25, \quad q_w = 0.9p_v / \lambda_w \quad (\text{A8.23})$$

For hot-rolled I-sections,

$$\lambda_w \leq 0.9, \quad q_w = p_v \quad (\text{A8.24})$$

$$\lambda_w > 0.9, \quad q_w = 0.9p_v / \lambda_w \quad (\text{A8.25})$$

in which

$$p_v = 0.6p_{yw} \quad (\text{A8.26})$$

$$\lambda_w = \sqrt{\frac{p_v}{q_e}} \quad (\text{A8.27})$$

$$\text{For } a/d \leq 1, \quad q_e = \left[0.75 + \frac{1}{(a/d)^2} \right] \left[\frac{1000}{d/t} \right]^2 \text{ in N/mm}^2 \quad (\text{A8.28})$$

$$\text{For } a/d > 1, \quad q_e = \left[1 + \frac{0.75}{(a/d)^2} \right] \left[\frac{1000}{d/t} \right]^2 \text{ in N/mm}^2 \quad (\text{A8.29})$$

λ_w is applicable to all steel grades at source.

Appendix 8.4

The compressive buckling strength p_c of a column for resistance to flexural buckling should be taken as the smaller root of the following equation.

$$(p_E - p_c)(p_y - p_c) = \eta p_E p_c \quad (\text{A8.30})$$

Hence

$$p_c = \frac{p_E p_y}{\phi_C + \sqrt{(\phi_C^2 - p_E p_y)}} \quad (\text{A8.31})$$

where,

$$p_E = \frac{\pi^2 E}{\lambda^2} \quad (\text{A8.32})$$

$$\phi_C = \frac{p_y + (\eta + 1)p_E}{2} \quad (\text{A8.33})$$

p_y is the design strength,

λ is the slenderness in clause 8.7.4

η is the Perry factor taken as,

$$\eta = \alpha (\lambda - \lambda_0) / 1000; \eta \geq 0 \quad (\text{A8.34})$$

$$\text{in which the limit slenderness should be taken as } \lambda_0 = 0.2 \sqrt{\frac{\pi^2 E}{p_y}} \quad (\text{A8.35})$$

and the Robertson constant should be taken as,

Curve (a₀), $\alpha=1.8$;

Curve (a), $\alpha=2.0$;

Curve (b), $\alpha=3.5$;

Curve (c), $\alpha=5.5$;

Curve (d), $\alpha=8.0$;

When using other steel grades, it may be necessary to determine the Perry factor or member bow imperfection for a manual or a second-order analysis. Perry factors above can be used for member design or member bow imperfection in Table 6.1 can be used for second-order analysis. The Perry factor can be related to the member bow imperfection e_0 as,

$$\eta = \frac{e_0 \bar{y}}{r^2}$$

in which \bar{y} is the maximum distance from centroidal axis of a section and r is the radius of gyration.

9 CONNECTIONS

9.1 GENERAL

The structural properties of connections should conform to the global analysis method used and comply with the assumptions made in the design of members given in section 6. Connections should be designed on the basis of direct load paths and by taking account of both the stiffness and strength of the various parts of the connection. Connection design relies on the ductility of steel to relieve residual stresses, which may generally be ignored in normal cases.

The connections between members should be capable of withstanding the forces and moments to which they are subjected, within acceptable deformation limits and without invalidating the design assumptions. Clauses 6.11.1, 6.11.2 and 6.11.3 describe these assumptions for pinned, rigid and semi-rigid connections respectively.

Detailing of the connections should take into account possible dimensional variations caused by rolling tolerances and fabrication variations which may lead to a small degree of lack of fit.

Where possible in connection design, members should be arranged on the principle that their centroidal axes coincide with the action lines of the forces in the members. Where this is not practical, the effects of additional moments due to eccentricity shall be taken into account in the design of the connection. In the case of bolted connections consisting of angles and T-sections, the intersection of the setting-out lines of the bolts may be adopted instead of the intersections of the centroidal axis. The effects of fatigue need not normally be considered in the design of connections for building structures, unless there are members supporting cranes or heavy vibratory plant or machinery, see clause 2.3.3. In the latter cases, reference should be made to specialist fatigue literature or design codes, see Annex A1.10.

The practicability of carrying out fabrication and erection work shall be considered in the design and detailing of connections:

- (a) **Shop fabrication**
- the requirements of the welding procedures for the materials and joint types concerned.
 - accessibility for welding.
 - welding constraints.
 - effects of angular and length tolerances on fit-up, i.e. minimising residual stress and distortion.
 - allowance for dimensional variation on rolled sections.
 - inspection and testing, including considerations of access for testing welds of partially completed complex connections before such welds are inaccessible.
 - surface treatment.
- (b) **Site fabrication and erection**
- clearances necessary for installing and tightening fasteners.
 - Allowance in terms of slotted holes, shim packing etc. for dimensional tolerances.
 - need for access for field welding.
 - effects of angular and length tolerances on fit-up, i.e. minimising residual stress and distortion.
 - welding constraints.

9.2 WELDED CONNECTIONS

9.2.1 Through-thickness tension

Corner or T-joint welding details of rolled sections or plates involving transfer of tensile forces in the through-thickness direction should be avoided whenever possible.

If tensile stresses are transmitted through the thickness of the connected part, the connection detail, welding procedure and sequence of welding shall be designed to minimise constraints which can cause additional tensile stresses in the through-thickness direction from weld shrinkage. The through-thickness properties of the part should be such as to minimise the risk of lamellar tearing.

9.2.2 Types of welds

For the purposes of design, welds may be classified as:

- (a) **Fillet welds**
 - continuous welds.
 - intermittent welds.
 - plug welds on circular and elongated holes.
 - slot welds.
- (b) **Butt welds**
 - full penetration butt welds.
 - partial penetration butt welds.
 - butt welds reinforced with fillet welds.
- (c) **Flare groove welds**

9.2.3 Weldability and electrodes

Steel material shall have good weldability such that crack-free and sound structural joints can be produced without great difficulty, special or expensive requirements on the welding procedure. The welding procedure (including all parameters such as preheating or post-heating requirements, interpass temperature, AC/DC current value, arc speed etc.) shall take into account of the properties of the parent material including the carbon equivalent (CE) value, thickness and the welding consumable type. The chemical contents and mechanical properties of steel material shall conform to the requirements in section 3.1. The welding consumable shall conform to the acceptable standards given in Annex A1.4 with chemical contents matching the parent metal and mechanical properties not inferior to the parent metal.

9.2.4 Welded connections to unstiffened flanges

In a T-joint of a plate to an unstiffened flange of I, H or box section, a reduced effective breadth b_e should be used for both the parent members and the welds.

- (a) For I or H section, b_e should be obtained from Figure 9.1 as

$$b_e = t_c + 2r_c + 5T_c \quad (9.1)$$

$$\text{but } b_e \leq t_c + 2r_c + 5 \left(\frac{T_c^2}{t_p} \right) \left(\frac{p_{yc}}{p_{yp}} \right)$$

where

- p_{yc} is the design strength of the member
- p_{yp} is the design strength of the plate
- r_c is root radius of rolled section or toe of fillet on welded section
- T_c is the thickness of connected flange
- t_c is the stem of connected structural member
- t_p is the thickness of the connected plate

- (b) For box sections, b_e should be obtained from
- $$b_e = 2t_c + 5T_c \tag{9.2}$$

but $b_e \leq 2t_c + 5 \left(\frac{T_c^2}{t_p} \right) \left(\frac{\rho_{yc}}{\rho_{yp}} \right)$

If b_e is less than 0.7 times the full breadth, the joint should be stiffened.

Using b_e as the weld length, the capacity of the weld P_x should be obtained from:

$$P_x = \rho_w a b_e \tag{9.3}$$

in which ρ_w is the design strength of weld and a is the throat thickness.

The strength of the connected plate at the weld, e.g. the flange of a beam, should be considered by using b_e as the effective breadth.

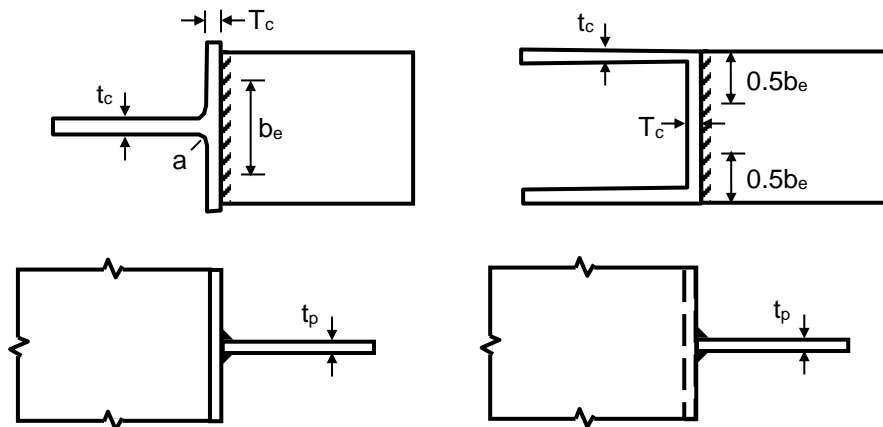

Figure 9.1 - Effective breadth of an unstiffened Tee-joint

9.2.5 Strength of welds

9.2.5.1 Fillet welds

9.2.5.1.1 Cross sectional geometry

The intersection angle between the fusion faces of fillet welds should be between 60° and 120° . The size of the fusion faces, referred to as leg length s , and the throat size a is defined in Figure 9.2.

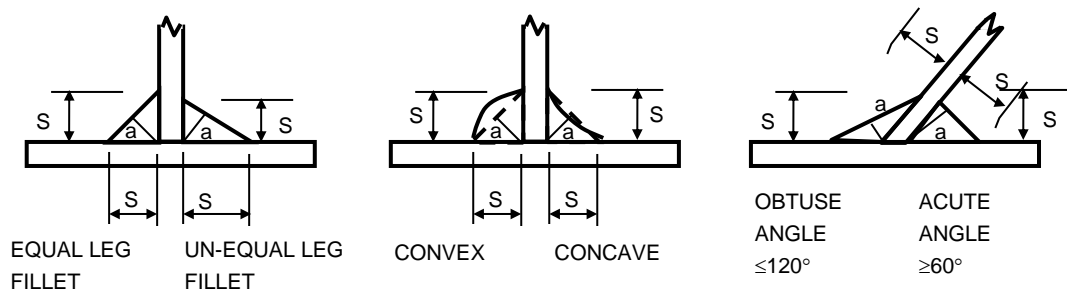

Figure 9.2 - Geometry of fillet welds

9.2.5.1.2 Weld size

(a) Leg length s

The minimum leg length of a fillet weld should not be less than that specified in Table 9.1 and should be able to transmit the calculated stress. For a T-joint the minimum leg length is not required to be greater than the thickness of the thinner part.

Table 9.1 - Minimum leg length of a fillet weld

Thickness of the thicker part (mm)	Minimum leg length (for unequal leg weld, the smaller leg length should be considered) (mm)
up to and including 6	3
7 to 13	5
14 to 19	6
over 19	8

For a weld along the edge of a plate:

- (i) If the thickness of plate is less than 6 mm, the maximum leg length should be the thickness of the plate.
- (ii) If the thickness of the plate is equal to or greater than 6 mm, the maximum leg length should be the thickness of the plate minus 2 mm.

(b) Throat size a

- (i) As shown in Figure 9.2, the throat size a is defined as the perpendicular length from the point of intersection of the connected plates to the inclined weld surface.
- (ii) Slight concavity or convexity of weld profile is allowed but the throat size should be determined according to Figure 9.2.
- (iii) If the welds are on both sides, the throat size on each side should not be greater than thickness of the thinner part with both sides welded.

9.2.5.1.3 Effective length

The effective length of a fillet weld should be its full length of weld less $2s$ with its end return excluded, but should not be less than 40 mm. A fillet weld with an effective length less than $4s$ or 40mm should not be used to carry load.

For a flat-bar tension member, if only longitudinal fillet welds are used for end connections, the length of each fillet weld should not be less than the width of the flat bar.

9.2.5.1.4 End returns

Fillet welds should not be terminated at the extreme ends or edges of members. They should either be returned continuously around the ends or edges for a length of not less than $2s$ or, if a return is impracticable, terminated not less than s from the ends or edges. The return and termination should not be included for calculation of the effective length of the weld.

In the case of fillet welds on the tension side or the tension end of a connection when subjected to significant moment from brackets, beam seats, framing angles, simple end plates, etc., the connection should be detailed with considerations of the practicality of making end returns as illustrated in Figure 9.3.

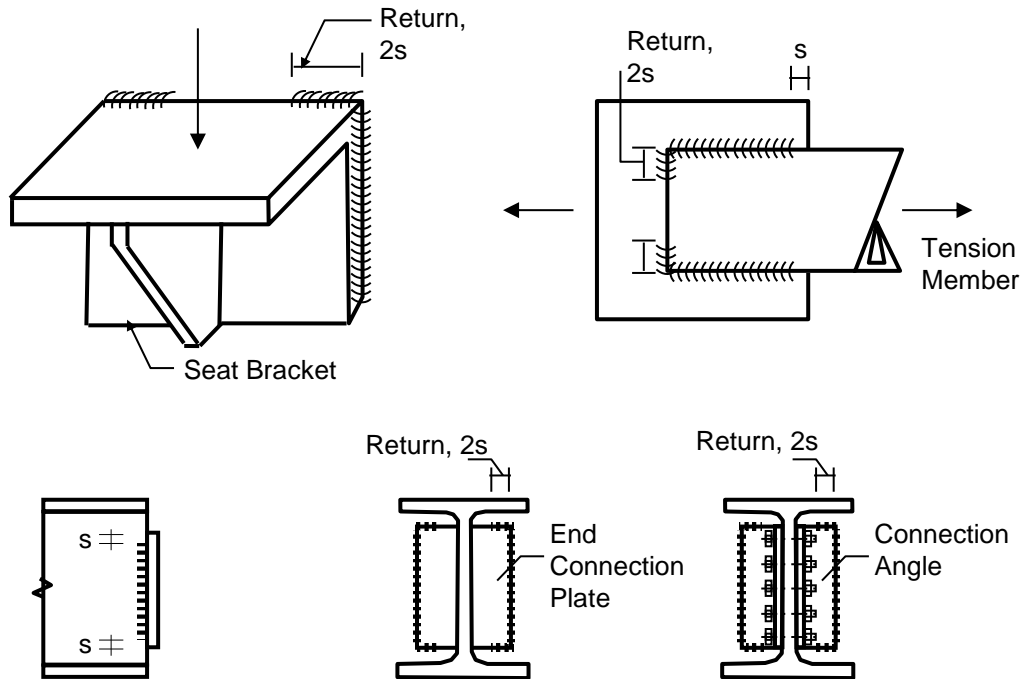

Beam End Connection

Figure 9.3 - End return of welds

Table 9.2a - Design strength of fillet welds p_w for BS-EN and American Welding Society (AWS) Standards

Steel grade	Electrode Grade					For other types of electrode and/or steel grades: $p_w = 0.5U_e$ but $p_w \leq 0.55 U_s$ where U_e is the minimum tensile strength of the electrode specified in the relevant product standard; U_s is the specified minimum tensile strength of the parent metal.
	AWS standards					
	ER60	ER70	ER80	ER90	ER110	
	EN ISO standards					
	35	42	50	55	69	
S275	220	(220) ^a	(220) ^a	(220) ^a	(220) ^a	
S355	(220) ^b	250	(250) ^a	(250) ^a	(250) ^a	
S460	(220) ^b	(250) ^b	280	(280) ^a	(280) ^a	
S550	(220) ^b	(250) ^b	(280) ^b	320	(320) ^a	
S690	(220) ^b	(250) ^b	(280) ^b	(320) ^a	385	

a) Over-matching electrodes.

b) Under-matching electrodes.

Table 9.2b - Design strength of fillet welds p_w for GB or other Standards

Steel grade	Electrode classification	Design strength N/mm ²	For other types of electrode and/or steel grades: $p_w = 0.38U_e$ $U_e \geq U_s$ where U_e is the minimum tensile strength of the electrode specified in the relevant product standard; U_s is the specified minimum tensile strength of the parent metal.
Q235	E43	160	
Q345, Q355	E50	200	
Q390, Q420	E55	220	
Q550	E60	225	
Q690	E85	335	

Note :- The ultimate strength of electrodes shall be greater than or equal to the tensile strength of the parent metal.

9.2.5.1.5 Strength of fillet welds

The strength of a fillet weld p_w using electrodes or other consumables with chemical contents and mechanical properties not inferior to the parent metals and complying with the acceptable standards given in Annex A1.4 can be obtained from Tables 9.2a and 9.2b. When two different grades of parent materials are joined by fillet welds, the lower grade should be considered in the design.

Single sided fillet or partial penetration butt welds should not be used to transmit a bending moment about the longitudinal axis of the weld.

9.2.5.1.6 Capacity of fillet welds

The capacity of a fillet weld should be calculated using the throat size a , see clause 9.2.5.1.2(b), and the following methods:-

(a) Simplified method

Stresses should be calculated from the vector sum of forces from all directions divided by the weld throat area i.e. longitudinal and transverse forces and moment to ensure that it does not exceed the design strength of weld p_w .

(b) Directional method

In consideration of more accurate behaviour, the force per unit length should be resolved into a longitudinal shear F_L parallel to axis of the weld and a resultant transverse force F_T perpendicular to this axis. The corresponding capacities per unit length should be:-

$$P_L = p_w a \text{ (longitudinal direction)} \quad (9.4)$$

$$P_T = K P_L \text{ (transverse direction)} \quad (9.5)$$

The coefficient K should be obtained from:

$$K = 1.25 \sqrt{\frac{1.5}{1 + \cos^2 \theta}} \quad (9.6)$$

in which θ is the angle between the force F_T and the throat of weld, see Figure 9.4.

The stress resultants should satisfy the following relationship:

$$\left(\frac{F_L}{P_L}\right)^2 + \left(\frac{F_T}{P_T}\right)^2 \leq 1 \quad (9.7)$$

in which P_L and P_T are the respective permissible capacities per unit length of weld in the longitudinal and the transverse directions.

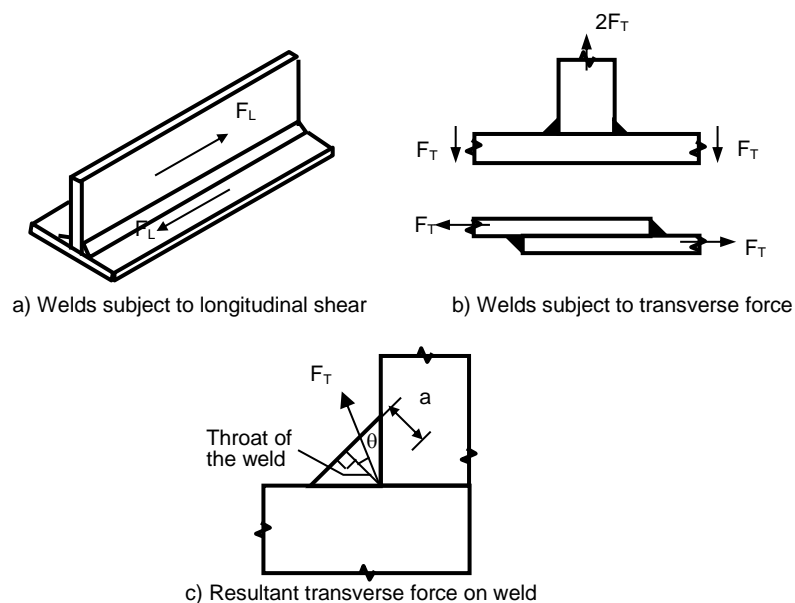

Figure 9.4 - Fillet welds – directional method

9.2.5.1.7 Intermittent fillet welds

Intermittent fillet welds may be used to transmit forces across a joint or faying surface.

- (a) The longitudinal spacing along any one edge of the element between effective lengths of weld should not exceed the least of
 - (i) 300 mm;
 - (ii) 16 times the thickness of the thinner part of compression elements; and
 - (iii) 24 times the thickness of the thinner part of tension elements.
- (b) A continuous fillet weld with a length of 3/4 of the width of narrower plate should be provided on each side of plate at both ends.
- (c) In staggered intermittent fillet welds, the clear unconnected gap should be measured between the ends of welds on opposing sides.
- (d) Intermittent fillet welds should not be used in corrosive conditions or to resist fatigue loads.

9.2.5.1.8 Plug welds

- (a) Plug welds are welds that fill up circular or elongated holes. Plug welds should not be used to resist tension. They may be used in the following situations:
 - to transmit shear on lap joints;
 - to prevent buckling or separation of lapped parts; or
 - to interconnect the components of built-up members.
- (b) The diameter of a circular hole, or width of an elongated hole, should be at least 8 mm larger than the thickness of the element containing the hole.
- (c) The effective shear area of a plug weld can be taken as the nominal area of the hole on the plane of the faying surface.
- (d) The thickness of a plug weld in an element up to 16 mm thickness should be equal to the thickness of the element. In material over 16 mm thick, thickness of a plug weld should be at least half of the thickness of the element but not less than 16 mm.
- (e) The minimum centre to centre spacing of plug welds should be 4 times their diameter but not greater than the distance necessary to prevent local buckling.

9.2.5.1.9 Slot welds

- (a) Slot welds are fillet welds in a slot. Slot welds may be used to transmit shear or to prevent buckling or separation of lapped parts. It should not be used to resist tension.
- (b) Slot welds should satisfy the requirements of plug welds in clause 9.2.5.1.8.
- (c) The length of the slot should not exceed 10 times the thickness of the weld.
- (d) The width of the slot should not be less than thickness of the element containing it plus 8 mm.
- (e) The ends of the slot should be semi-circular, except for those ends which extend to the edge of the element concerned.

9.2.5.1.10 Lap joints

The minimum lap should be $5t$ or 25 mm whichever is the greater, where t is the thickness of the thinner part joined.

For lap joints longer than 100s, a reduction factor β_{LW} should be taken to allow for the effects of non-uniform distribution of stress along its length.

$$L_{eff} = \beta_{LW} L_j \quad (9.8)$$

where

$$\beta_{LW} = 1.2 - 0.002 \left(\frac{a}{L_j} \right) \leq 1.0 \quad (9.9)$$

a = fillet weld leg size

L_j = actual length of weld

L_{eff} = effective length

A single fillet weld should not be used for lap joints unless the parts are restrained to prevent opening of the joint and eccentric moments.

9.2.5.2 Penetration welds

9.2.5.2.1 Full penetration welds

The design strength of a full penetration weld, or a butt weld, can be taken as equal to the parent metal if all the following conditions are satisfied:

- (a) A full penetration weld should have complete penetration and fusion of weld with parent metal throughout the thickness of the joint.
- (b) Welding consumables should possess mechanical properties not inferior to those specified for the parent metal.
- (c) The backing material should be not inferior to parent material.

The welding of single V, U, J, bevel or square butt welds should follow a proper procedure by depositing a sealing run of weld metal on the back of the joint. When welding is on one side only, facilitating this process by the use of temporary or permanent backing material or by using an approved specialist method without the need of using backing material is acceptable.

Precautionary measures against residual stresses should be taken to mitigate the adverse effect when welding plates with thickness greater than 40mm or in constrained or congested locations.

9.2.5.2.2 Partial penetration welds

(a) Throat size of partial penetration welds

The throat size of a single-sided partial penetration weld, see Figures 9.5(a) and 9.5(c), or the size of each throat of a double-sided partial penetration weld, see Figures 9.5(b) and 9.5(d), should be the minimum depth of penetration from that side of the weld.

The minimum throat size of a longitudinal partial penetration weld should be $2\sqrt{t}$ where t is the thickness of the thinner part joined.

(b) Capacity of partial penetration welds

A single-side partial penetration butt weld should not be used to resist a bending moment about its longitudinal axis to avoid possible tension at the root of the weld, nor to transmit forces perpendicular to the longitudinal axis that would significantly produce such a bending moment, see Figure 9.6.

The capacity of a partial penetration weld in a butt joint, see Figures 9.5(a) and 9.5(b), or a corner joint, see Figure 9.5(c), should be taken as sufficient if the stress does not exceed the relevant strength of the parent material throughout the weld.

The capacity of a T-butt joint comprising a pair of partial penetration butt welds with additional fillets, see Figure 9.5(d), should be determined by treating the weld as:

- a butt weld, if $a > 0.7s$;
- a fillet weld, see 9.2.5.1.6, if $a \leq 0.7s$;

in which a is the effective throat size and s is the length of the smaller fusion face, see Figure 9.5(d).

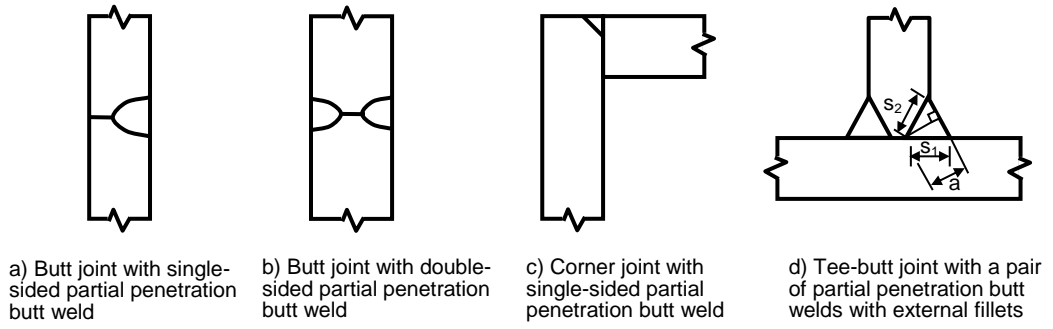

Figure 9.5 - Partial penetration butt welds

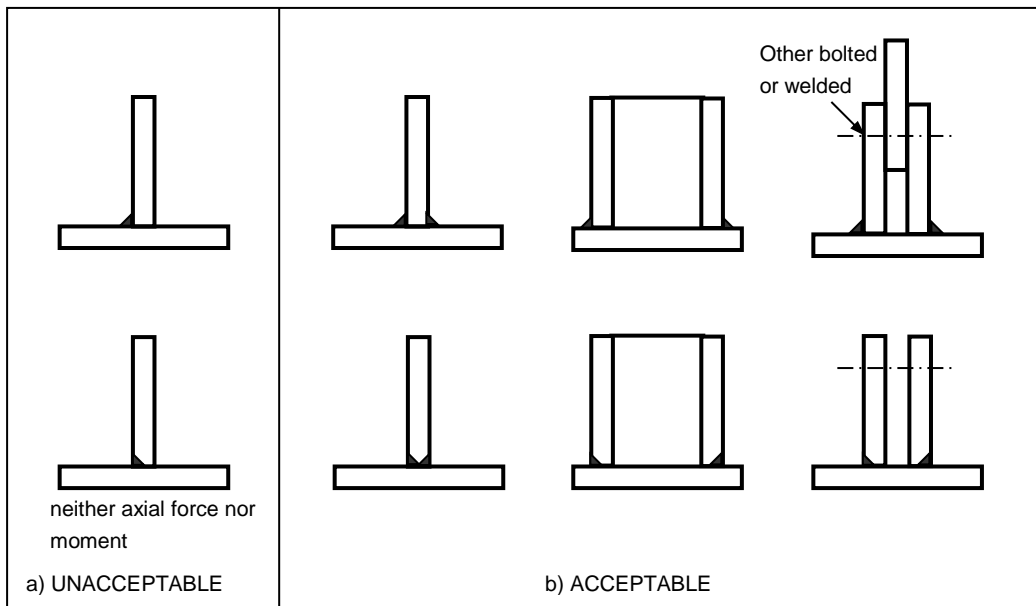

Figure 9.6 - Single and double sides of penetration welds

9.3 BOLTED CONNECTIONS

9.3.1 Bolt spacing

9.3.1.1 Minimum spacing

- (a) The spacing between centres of bolts in the direction of load transfer should not be less than $2.5d$, where d is the nominal diameter of the bolts. This spacing can be increased as necessary for bearing capacity.
- (b) The spacing between centres of standard holes measured perpendicular to the direction of load transfer should normally be $3d$. This spacing may be reduced to not less than $2.5d$ provided that the bearing on the bolt is not more than $2/3$ of P_{bb} (see clause 9.3.6.1.2).
- (c) The spacing for slotted holes should be measured from the centres of its end radius or the centreline of the slot.

9.3.1.2 Maximum spacing

The maximum spacing between centres of standard holes measured either parallel or perpendicular to the direction of load transfer should be limited to the lesser of $12t$ or 150 mm, where t is the thickness of the thinner connected plate.

9.3.2 End and edge distances

The end distance is the distance from the centre of a hole to the adjacent edge in the direction in which the fastener bears. The end distance shall be sufficient to provide adequate bearing capacity. The edge distance is the distance from the centre of a hole to the adjacent edge at right angles to the direction of stress.

The distance from the centre of a standard hole to the adjacent edge or end of any part, measured either parallel or perpendicular to the direction of load transfer, should be not less than those listed in Table 9.3.

Table 9.3 - Minimum end and edge distances of holes (for standard holes)

Bolt Size	At sheared and hand flame cut edge(mm)	At rolled edges of plates, shapes, bars or gas cut edges (mm)
M12	22	18
M16	28	22
M18	32	24
M20	34	26
M22	38	28
M24	42	30
M27 and over	$1.75d$	$1.25d$

The maximum end and edge distance should not be greater than $11t\varepsilon$, in which ε is the material constant equal to $\sqrt{275/p_y}$ and t is the thickness of the connected thinner plate. This does not apply to bolts interconnecting the components of back-to-back tension or compression members. For those exposed to a highly corrosive environment, the end and edge distance should not exceed $40 + 4t$.

Limiting the edge distance ensures adequate resistance against end shear, assists to exclude moisture and to prevent corrosion. More restriction should be exercised in severe conditions of exposure.

9.3.3 Hole dimensions

To compensate for shop fabrication tolerance and to provide some freedom for adjustment during erection, four types of holes are permitted as shown in Table 9.4.

For oversize holes, spacing, end and edge distances should be increased. The increment should be half of the difference between the diameters of an oversize hole and a standard hole.

Table 9.4 - Nominal hole dimensions

Bolt size	Standard hole	Oversize hole	Short slot hole	Long slot hole
	Diameter d (mm)	Diameter d (mm)	Width × Length (mm)	Width × Length (mm)
M12	14	16	14 × 18	16 × 30
M16	18	20	18 × 22	18 × 40
M18	20	22	20 × 24	20 × 45
M20	22	25	22 × 26	22 × 50
M22	24	27	24 × 28	24 × 55
M24	26	30	26 × 32	26 × 60
M27 and over	d + 3	d + 8	(d + 3) × (d + 10)	(d + 3) × (2.5d)

9.3.4 Sectional area of connected parts

9.3.4.1 Gross area

The gross area a_g should be computed as the products of the thickness and the gross width of the element, measured normal to its axis.

9.3.4.2 Net area

The net area a_n should be the gross area less the deductions for bolt holes. See Figure 9.7.

9.3.4.3 Deduction for bolt holes

(a) Holes not staggered

For bolts aligned perpendicular to the direction of force, the deduction should be the sum of sectional areas of the bolt holes.

(b) Staggered holes

Where the bolt hole are staggered, the deduction should be the greater of

- (i) The deduction for non-staggered holes, see Figure 9.7 line (1).
- (ii) The sum of the sectional area of all holes lying on diagonal or zig-zag line less a justification factor of $0.25S^2t/g$ for each gauge g that it traverses diagonally. See Figure 9.7 lines (2) and (3).
- (iii) For angles with bolts on both legs, the gauge length g should be the sum of the gauge lengths on each leg g_1 and g_2 measured from the heel minus the thickness t of the angle, see Figure 9.8.

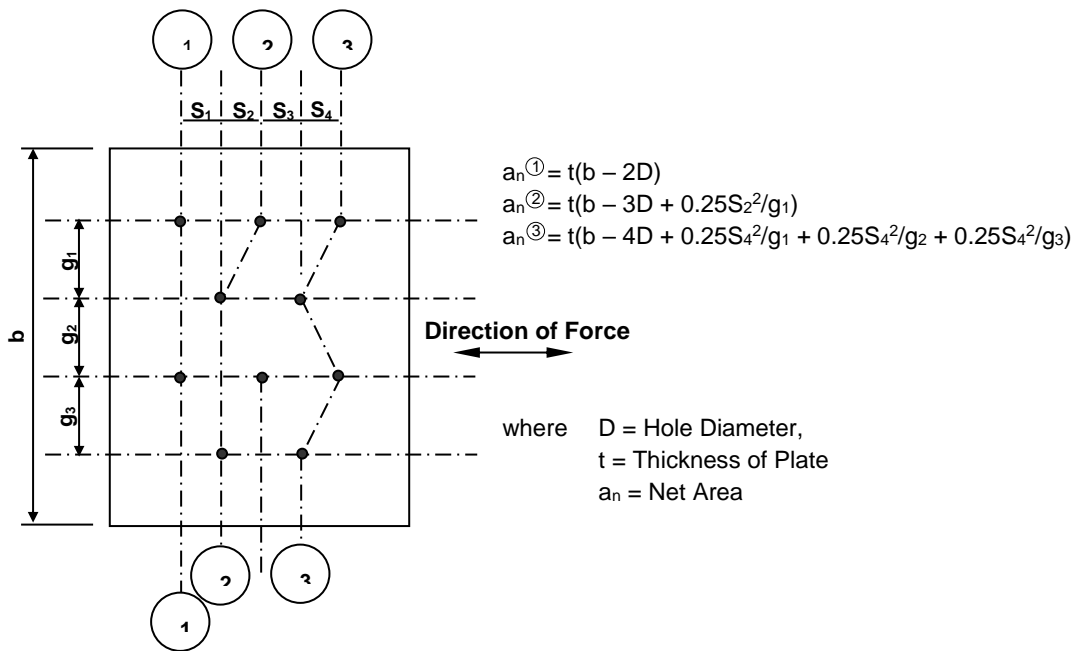

Figure 9.7 - Staggered holes

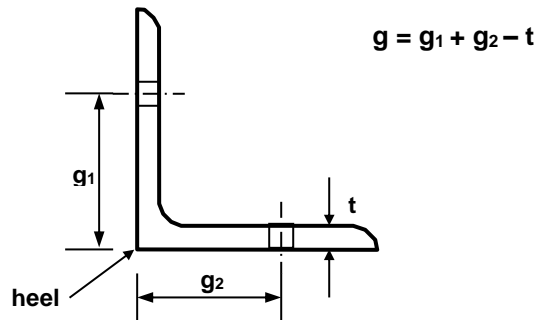

Figure 9.8 - Angles with hole in legs

9.3.4.4 *Effective area for tension*

The effective area a_e perpendicular to the force direction should be determined from

$$a_e = K_e a_n \leq a_g \quad (9.10)$$

where the effective net area coefficient K_e is given by

$K_e = 1.2$	for steel of grade S275
$K_e = 1.1$	for steel of grade S355
$K_e = 1.0$	for steel of grade S460
$K_e = 0.84$	for steel of grade S550
$K_e = 0.80$	for steel of grade S690

a_n is the net cross sectional area of the leg deduced for hole openings.

a_g is the gross sectional area without reduction for openings.

9.3.4.5 *Effective area for shear*

Bolt holes need not be allowed for in the shear area provided that:

$$A_{v.net} \geq 0.85 A_v / K_e \quad (9.11)$$

where	A_v	= gross shear area before hole deduction
	$A_{v.net}$	= net shear area after deducting bolt holes
	K_e	= effective net area coefficient from clause 9.3.4.4

Otherwise the net shear capacity should be taken as

$$0.7 p_y K_e A_{v.net} \quad (9.12)$$

9.3.5 Block shear

Block shear failure at a group of bolt holes near the end of web of a beam or bracket should be prevented by proper arrangement of a bolt pattern as shown in Figure 9.9. This mode of failure generally consists of tensile rupture on the tension face along the bolt line accompanied by gross section yielding in shear at the row of bolt holes along the shear face of the bolt group. On the tension side, the block shear capacity should be taken as,

$$P_r = (1/\sqrt{3})p_y A_{v,eff} \quad (9.13)$$

where $A_{v,eff}$ is the effective shear area defined as,

$$A_{v,eff} = t [L_v + K_e (L_t - k D_t)] \quad (9.14)$$

- t = thickness of connected part
 L_v = length of shear face, see Figure 9.9 below
 L_t = length of tension face
 K_e = effective net area coefficient see clause 9.3.4.4
 k = 0.5 for single row of bolts or 2.5 for two rows of bolts
 D_t = is the hole diameter for the tension face, but for slotted holes the dimension perpendicular to load direction should be used

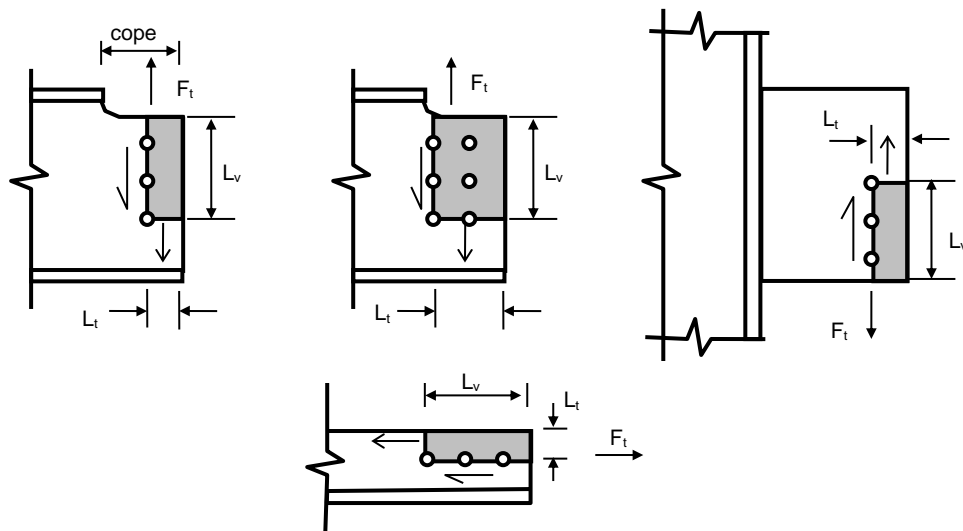

Figure 9.9 - Block shear and effective shear area

9.3.6 Design strength of bolts under shear and bearing

9.3.6.1 Shear capacity of non-preloaded bolts

This category of connection may be referred to as a "Bearing Type Connection". For this type of connection, no preload or special treatment on contact surfaces is required. Ordinary bolts of ISO grade 4.6 or equivalent manufactured from low carbon steel to high strength bolts of ISO grade 10.9 or equivalent may be used.

9.3.6.1.1 Shear capacity of bolts

The shear capacity P_s of a bolt should be taken as

$$P_s = p_s A_s \quad (9.15)$$

where

p_s is the design shear strength obtained from Table 9.5

A_s is the effective shear area

- for the case of the bolt thread occurring in the shear plane, A_s is taken as the tensile area A_t .
- for the case of the bolt thread not occurring in the shear plane, A_s is taken as the cross sectional area of the shank.

The shear strength p_s should be reduced due to the effect of bolting conditions, see clauses 9.3.6.1.4 to 9.3.6.1.6 below.

Table 9.5 - Design shear strength of bolts

Bolt grade		Design shear strength p_s (N/mm ²)
ISO	4.6	160
	6.8	240
	8.8	375
	10.9	400
	12.9	480
BS	General grade HSFG \leq M24 \geq M27	400
		350
	Higher grade HSFG	400
ASTM	A307	124
	A325	248
	A490	311
GB50017	8.8	250
	10.9	310
Other grades ($U_b \leq 1200$ N/mm ²)		$0.4U_b$
<i>Note: U_b is the specified minimum tensile strength of the bolt.</i>		

9.3.6.1.2 Bearing capacity of bolts

The bearing capacity P_{bb} of a bolt bearing on connecting parts should be taken as

$$P_{bb} = d t_p p_{bb} \quad (9.16)$$

where d is the nominal diameter of the bolt

t_p is the thickness of the thinner connecting part

p_{bb} is the bearing strength of the bolt obtained from Table 9.6

Table 9.6 - Design bearing strength of bolts

Bolt grade		Design bearing strength p_{bb} (N/mm ²)
ISO	4.6	460
	6.8	900
	8.8	1000
	10.9	1300
	12.9	1600
BS	General grade HSFG \leq M24 \geq M27	1000
		900
	Higher grade HSFG	1300
ASTM	A307	400
	A325	450
	A490	485
GB50017	8.8	720
	10.9	930
Other grades ($U_b \leq 1000$ N/mm ²)		$0.7(U_b + Y_b)$
<i>Note: U_b is the specified minimum tensile strength of the bolt. Y_b is the specified minimum yield strength of the bolt.</i>		

9.3.6.1.3 Bearing capacity of connected parts

The bearing capacity P_{bs} of the connected parts should be the least of the followings

$$P_{bs} = k_{bs} d t_p p_{bs} \quad (9.17)$$

$$P_{bs} = 0.5 k_{bs} e t_p p_{bs} \quad (9.18)$$

and

$$P_{bs} = 1.5 l_c t_p U_s \leq 2.0 d t_p U_b \quad (9.19)$$

in which

e is the end distance, measured in the same direction of load transfer

p_{bs} is bearing strength of connected parts

- for steel of grade S275, $p_{bs} = 460$ MPa
- for steel of grade S355, $p_{bs} = 550$ MPa
- for steel of grade S460, $p_{bs} = 670$ MPa
- for steel of grade S550, $p_{bs} = 770$ MPa
- for steel of grade S690, $p_{bs} = 940$ MPa
- for steel of other grades, $p_{bs} = 0.67(U_s + Y_s)$

(9.20)

(refer to section 3 for other grades of steel)

k_{bs} is hole coefficient taken as

- for standard holes $k_{bs} = 1.0$
- for over size holes $k_{bs} = 0.7$
- for short slotted holes $k_{bs} = 0.7$
- for long slotted holes $k_{bs} = 0.5$

l_c is net distance between the bearing edge of the holes and the near edge of adjacent hole in the same direction of load transfer.

9.3.6.1.4 Long joints

In a lapped joint of bearing type, when the distance L_j between the centres of two end bolts measured in the direction of load transfer is larger than 500 mm as shown in Figure 9.10, the shear capacity P_s of all the bolts calculated from clause 9.3.6.1.1 should be reduced by multiplying a reduction factor β_L as

$$\beta_L = \left(\frac{5500 - L_j}{5000} \right) < 1.0 \quad (9.21)$$

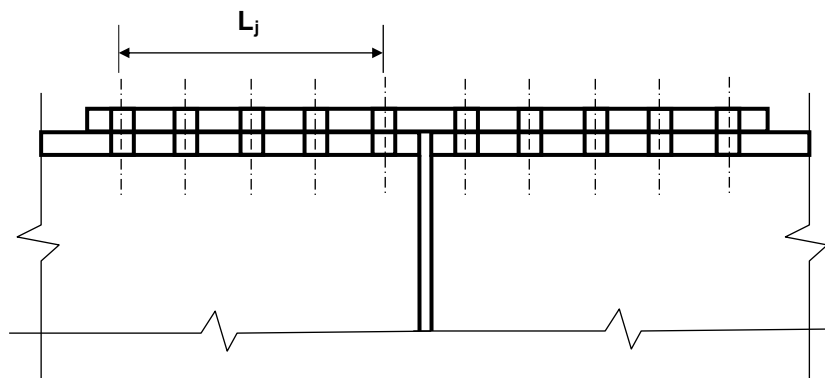

Figure 9.10 - Lap length of a splice

Note that this provision does not apply to a full length connection with uniform load distribution, e.g. the bolted connection of flanges to web of a plate girder.

9.3.6.1.5 Long grip length

Where the grip length T_g (i.e. the total thickness of the connected plies) is greater than $5d$, the shear capacity P_s should be reduced by multiplying a reduction factor β_g given by,

$$\beta_g = \frac{8d}{3d + T_g} \quad (9.22)$$

9.3.6.1.6 Bolts through packing

When a bolt passes through packing with thickness t_{pa} greater than one-third of the nominal diameter d , its shear capacity P_s should be reduced by multiplying a reduction factor β_p obtained from:

$$\beta_p = \left(\frac{9d}{8d + 3t_{pa}} \right) \leq 1.0 \quad (9.23)$$

For double shear connections with packing on both sides of connecting member, t_{pa} should have the same thickness; otherwise, the thicker t_{pa} should be used.

This provision does not apply to preloaded bolt (friction-type) connections when working in friction, but does apply when such bolts are designed to slip into bearing.

9.3.6.2 Shear capacity of preloaded bolts

Only high strength friction grip bolts of ISO grade 8.8 or above should be used for preloaded bolts. High strength friction grip bolts complying with the acceptable references in Annex A1.3 should be used as such bolts have stronger heads and nuts to ensure failure occurs in the bolt shank. The bolts should be preloaded to the required tension with controlled tightening to generate the required gripping forces so that slip between the connected parts will not occur at ultimate limit state. The factored load on each bolt should not exceed the slip resistance P_{SL} taken from the following equation:

$$P_{SL} = 0.9 K_s \mu P_o \quad (9.24)$$

where

P_o is the minimum proof loads of bolts specified in relevant international or local standards.

μ is the slip factor between connected parts. It may be obtained from Table 9.7 or determined from the results of test as specified to relevant standards.

K_s is the coefficient allowing for type of hole

- for standard holes $K_s = 1.0$
- for oversize holes $K_s = 0.85$
- for slotted holes, loaded perpendicular to slot $K_s = 0.85$
- for slotted holes, loaded parallel to slot $K_s = 0.7$

Table 9.7 - Slip factors for preloaded bolts

Class	Condition of faying surfaces		Slip factor μ
	Preparation	Treatment	
A	Blasted with shot or grit	Loose rust removed, no pitting	0.5
		Spray metallized with aluminium	
		Spray metallized with a zinc based coating that has been demonstrated to provide a slip factor of at least 0.5	
B	Blasted with shot or grit	Spray metallized with zinc	0.4
C	Wire brushed	Loose rust removed, tight mill scale	0.3
	Flamed cleaned		
D	Untreated	Untreated	0.2
	Galvanized		

Should slip between the connected parts occur the bolts should be designed as bearing type.

9.3.7 Design strength of bolts in tension

9.3.7.1 Tension capacity of bolts

The tension capacity P_t of a bolt should be taken as

$$P_t = A_s p_t \quad (9.25)$$

where

A_s is the tensile stress area

p_t is tension strength obtained from Table 9.8.

Table 9.8 - Design tension strength of bolts

Bolt grade		Design tension strength p_t (N/mm ²)
ISO	4.6	240
	6.8	480
	8.8	560
	10.9	700
	12.9	810
BS	General grade HSFG $\leq M24$	590
	$\geq M27$	515
	Higher grade HSFG	700
ASTM	A307	310
	A325	620
	A490	780
GB50017	8.8	400
	10.9	500
Other grades ($U_b \leq 1200$ N/mm ²)		$0.7 U_b$ but $\leq Y_b$
Note: U_b is the specified minimum tensile strength of the bolt. Y_b is the specified minimum yield strength of the bolt.		

9.3.7.2 Prying force

(a) Design against prying force is not required provided that all the following conditions are satisfied.

(i) Bolt tension capacity P_t is reduced to

$$P_{nom} = 0.8 A_t p_t \quad (9.26)$$

in which P_{nom} is the nominal tension capacity of the bolt.

(ii) The bolt gauge G on the flange of UB, UC and T sections does not exceed $0.55B$, in which B is total width of the flange, see Figure 9.11.

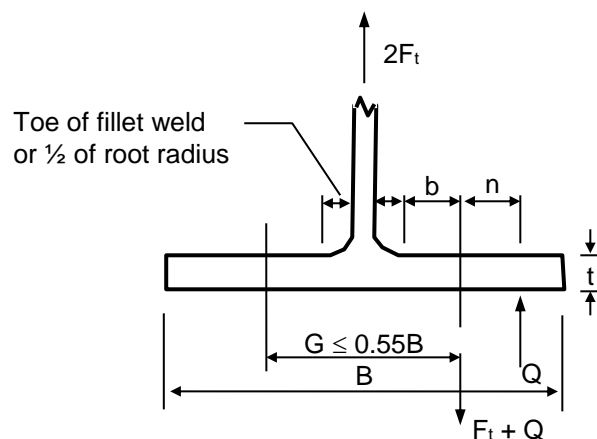

Figure 9.11 - Prying force

(b) If the conditions described in (a) above cannot be satisfied, the prying force Q should be calculated and taken into account and F_{tot} should be calculated as follows:

$$F_{tot} = F_t + Q < P_t \quad (9.27)$$

F_{tot} is the total applied tension in the bolt including the prying force, and F_t is the

tension force in the bolt.

9.3.8 Combined shear and tension

9.3.8.1 Tension combined with non-preloaded bolts

Both shear and tension will directly act to the bolts.

(a) For bolts without consideration of prying force

$$\frac{F_s}{P_s} + \frac{F_t}{P_{nom}} \leq 1.4 \quad (9.28)$$

(b) For bolts with consideration of prying force

$$\frac{F_s}{P_s} + \frac{F_{tot}}{P_t} \leq 1.4 \quad (9.29)$$

9.3.8.2 Tension combined with preloaded bolts

It is still assumed that there is no slip between the connected parts under shear force. However, the gripping force will be reduced by the tension force. The combined effect of tension and shear should be

$$\frac{F_s}{P_{SL}} + \frac{F_{tot}}{0.9P_0} \leq 1.0 \quad (9.30)$$

in which P_{SL} is the slip resistance of a preloaded bolt, P_0 is the specified minimum proof load and F_s is the applied shear.

9.3.9 Bolts combined with welds

Only preloaded bolts designed to be non-slip and tightened after welding may share load with welds.

In alteration and addition works, if the existing bolted connections are HSFG type or load reversal is not expected, the existing bolts are permitted to carry loads present at the time of the alteration and any new welds shall be designed to resist the additional design loads.

9.3.10 Pin connections

9.3.10.1 Pin connected tension members

In pin connected tension members and their connecting parts, the thickness of an unstiffened element containing a hole for a pin should be not less than 25% of the distance from the edge of the hole to the edge of the element, measured perpendicularly to the axis of the member, see Figure 9.12. Where the connected elements are clamped together by external nuts, this limit on thickness need not be applied to internal plies.

The net cross-sectional area beyond a hole for a pin, in all directions within 45° of the member axis shown in Figure 9.12, should not be less than the net cross-sectional area A_r required for the member. When measured perpendicular to the member axis, the net cross-sectional area on each side of the hole should not be less than $2A_r/3$.

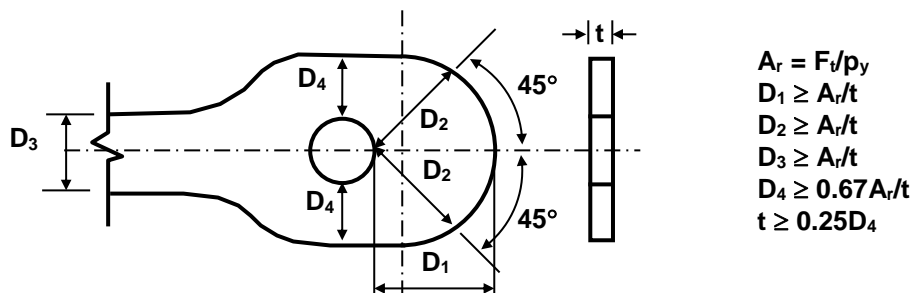

Figure 9.12 - Pin-ended tension member

9.3.10.2 Design of pins

9.3.10.2.1 General

All pins shall be provided with locking devices to ensure that the pin does not move away from its position in service. The capacity of a pin connection should be determined from the shear capacity of the pin, see clause 9.3.10.2.2, and the bearing capacity on each connected part, see clause 9.3.10.2.3, taking due account of the distribution of load between the various parts. The moment in the pin should also be checked, see clause 9.3.10.2.4.

9.3.10.2.2 Shear capacity

The shear capacity of a pin should be taken as follows:

- a) if rotation is not required and the pin is not intended to be removable:

$$0.6 p_{yp} A \quad (9.31)$$

- b) if rotation is required or if the pin is intended to be removable:

$$0.5 p_{yp} A \quad (9.32)$$

where

A is the cross-sectional area of the pin

p_{yp} is the design strength of the pin

9.3.10.2.3 Bearing capacity

The bearing capacity of a pin should be taken as follows:

- a) if rotation is not required and the pin is not intended to be removable:

$$1.5 p_y d t \quad (9.33)$$

- b) if rotation is required or if the pin is intended to be removable:

$$0.8 p_y d t \quad (9.34)$$

where

d is the diameter of the pin

p_y is the smaller of the design strengths of the pin and the connected part

t is the thickness of the connected part

9.3.10.2.4 Bending

The bending moment in a pin should be calculated on the assumption that the connected parts form simple supports. It should generally be assumed that the reactions between the pin and the connected parts are uniformly distributed along the contact length on each part, see Figure 9.13.

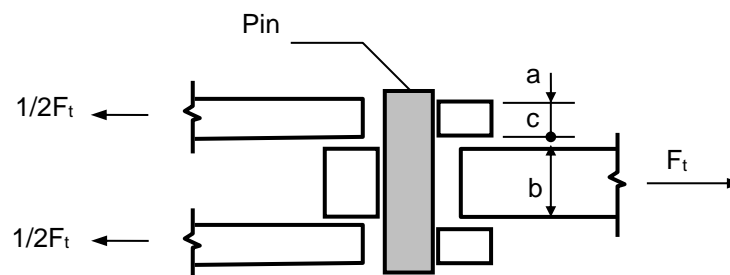

Figure 9.13 - Bending action in pinned connection

The moment capacity of the pin should be taken as follows:

a) if rotation is not required and the pin is not intended to be removable: (9.35)

$$1.5 p_{yp} Z$$

b) if rotation is required or if the pin is intended to be removable: (9.36)

$$1.0 p_{yp} Z$$

where

p_{yp} is the design strengths of the pin

Z is the elastic section modulus of the pin

9.3.11 Connections for hollow sections of lattice girders

The design of connections of hollow sections members of trusses should be based on the following criteria as relevant.

- (a) Chord face failure
- (b) Chord web (or wall) failure by yielding or instability
- (c) Chord shear failure
- (d) Chord punching shear failure
- (e) Local buckling failure
- (f) Braces (web members) failure with reduced effective width
- (g) Load eccentricities

Their design can be complex and good guidance and rules may be found from specialist literature, see Annex A1.3.

9.4 BASEPLATE AND ANCHOR CONSTRUCTION

9.4.1 Column base plates

Steel columns should be provided with a steel base plate of sufficient size, stiffness and strength to distribute the forces due to axial, bending and shear effects as appropriate from the column to the support without exceeding the load carrying capacity of the support. The nominal bearing pressure between the base plate and the support should be determined by assuming a linear distribution. The maximum stress induced on concrete foundation should not be larger than $0.6f_{cu}$ in which f_{cu} is the lesser of the concrete or the bedding grout 28-day cube strength.

Steel base plate with design strength not larger than 275 N/mm^2 should be used for transmitting moments, and its thickness should be designed to prevent from brittle fracture if the base plate is exposed to external weather conditions.

- (a) Base plates with axial forces applied concentrically may be designed by the effective area method. As shown on Figure 9.14, only the shaded portion of the base plate is considered to be effective to transmit the full design pressure of $0.6f_{cu}$ to the support. The thickness t_p of the base plate can be determined by

$$t_p = c \sqrt{\frac{3w}{p_{yp}}} \quad (9.37)$$

where

c is the largest perpendicular distance from the edge of the effective portion of the base plate to the face of the column cross-section, see Figure 9.14.

w is the pressure under the effective portions of the base plate. It can be assumed as uniform distribution over entire effective portion but should be limited to $0.6 f_{cu}$.

p_{yp} is the design strength of the base plate.

t, T are respectively the thickness of the thinner and thicker parts of the column section including the stiffeners, if any.

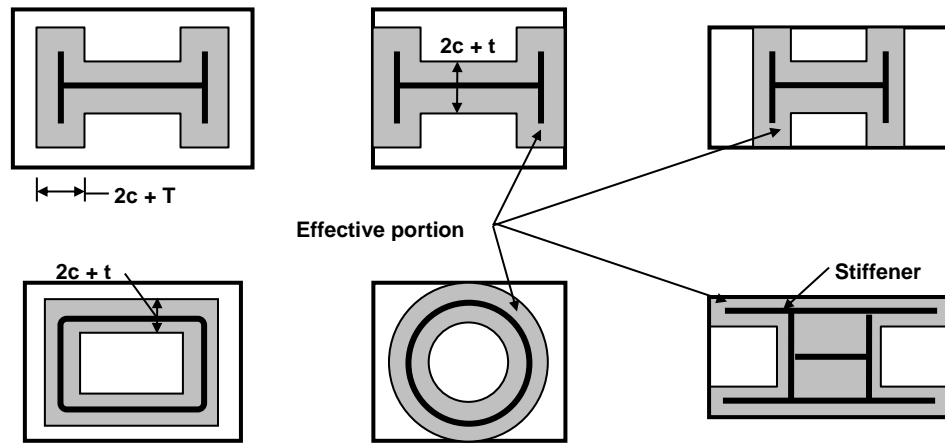

Figure 9.14 - Typical base plates

- (b) If moments are applied to the base plate through the column, either caused by eccentric axial loads or direct moments, the base plate should be analysed by elastic linear analysis. The pressure under the compression zone may be considered as uniform or linearly distributed.

Stiffeners may be used to reinforce the base plate. These stiffeners should resist the total moment due to the design anchor tension or concrete pressure on the base plate and should not exceed

$$M_s \leq p_{ys} Z_s \quad (9.38)$$

where

p_{ys} = design strength of stiffener

Z_s = section modulus of stiffener

- (c) Alternatively to (a) and (b) above, the Responsible Engineer may justify the design of a base plate by other means using acceptable structural principles.

The column may be connected to the base plate, either with or without gussets, by welding or bolting. The welds or bolts should be provided to transmit the total forces and moments unless tight bearing contact can be ensured such that welds or bolts transmit only shear and tension forces.

9.4.2 Anchor bolts for base plates, wall plates and hangers

Anchor bolts shall be required to attach steel plates to concrete structure, typically for column base plates, beam wall support plates, hangers and cladding steelwork.

Anchor bolts should be able to resist forces from the most severe design load combination of wind, imposed, permanent, construction and other loads. They should be designed to take the tension due to uplift forces and bending moment as appropriate. If no special element for resisting shear force is provided, such as shear key on the bottom of a column base plate or other restraint system, the anchor bolts should be designed to resist the shear forces in addition to the tension forces. Friction between the base plate and concrete or grout should not normally be considered to provide shear resistance.

The long-term durability of the anchorage system should be considered. Where corrosion is possible, materials with good corrosion resistance such as stainless steel or hot-dip galvanized steel may be used or a heavy-duty paint system employed.

(a) Cast-in anchor bolts

The cast-in anchor bolts may be fabricated from high yield reinforcing bars, plain bars of grade S275 or other grades of steel.

(i) Straight or hooked bars

This type of bolts is anchored by bond stress between steel and concrete. The design anchorage bond stress is assumed to be constant over the bond length. The minimum bond length should be calculated by

$$l = \frac{F_t}{\pi d f_{bu}} \quad (9.39)$$

where

F_t = total factored tension in bolt

d = diameter (nominal) of bolt

f_{bu} = design ultimate anchorage bond stress

$$= \beta \sqrt{f_{cu}}$$

β = coefficient dependent on bar type and equal to

0.28 for plain bar in tension;

0.35 for plain bar in compression;

0.50 for deformed bar in tension; and

0.63 for deformed bar in compression

f_{cu} = concrete cube strength on 28 days

The design of the bolt should be the same as ordinary bearing type bolted connections. Net area at thread portion of the anchor bolt should be used for design calculation. Interaction for combining tension and shear should be the vector sum of the ratio of design to capacity and should not be greater than unity as,

$$\left(\frac{V}{V_c}\right)^2 + \left(\frac{F_t}{P_t}\right)^2 \leq 1 \quad (9.40)$$

where

V, F_t are factored shear and tension respectively.

V_c, P_t are shear and tension capacities of anchor bolt respectively.

(ii) Headed bolts

This type of bolts is associated with washer plate (bearing plate) fixed at the embedded end of the bolt by either welding or nuts. Bond stress should not be taken into account for anchorage force. The total tension resisted by the washer plate should be calculated using the theory of shear cone on concrete.

(b) Drilled-in anchor bolts

Drilled-in anchors should only be used in existing concrete and in situations where they are required to resist significant tension, their uses should be avoided whenever possible. Their design and installation should be strictly in accordance with manufacturer's specification.

(c) Anchor bolts for hangers

There is often no redundancy in hanger systems and the Responsible Engineer should assess the consequences of failure of a particular system and, if it is considered necessary an additional partial safety factor should be used to account for this.

Anchor bolts for attaching steel hangers to new concrete beams or slabs should be mechanically locked around top reinforcement using hooks or top plates embedded in the concrete. Anchor bolts for attaching steel hangers to existing concrete beams or slabs should take the form of through bolts with substantial top

plates. The use of expansion or chemical anchors in this situation should be avoided if at all possible.

9.5 STEEL CASTINGS AND FORGINGS

Steel castings and forgings may be used in bearings, connection or other parts for architectural aesthetics or because of joint node complexity. They are particularly well suited for nodes of structural hollow section structures with several members meeting at a single point. For details of the use of castings in buildings see Annex A2.2 and see Annex A1.2 for acceptable references for materials for castings and forgings.

Connections of castings or forgings may be designed by means of testing (see section 16), analysis or other rational methods.

Performance tests may be required to demonstrate the safety and functionality of castings or forgings in addition to valid mill certificates.

10 COMPOSITE CONSTRUCTION

This section gives recommendations for the interactive behaviour between structural steel and concrete designed to utilize the best load-resisting characteristics of each material. Detailed design considerations and design methods of the following composite members are provided:

- Composite beams with either a solid slab or a composite slab using profiled steel sheets.
- Composite slabs with profiled steel sheets of either trapezoidal or re-entrant cross-sections.
- Composite columns with fully encased H sections, partially encased H sections and infilled rectangular and circular hollow sections.

Recommendation on the use of shear connectors is also given. However, the design of composite joints is not covered, and reference to specialist design recommendation shall be made.

10.1 MATERIALS

10.1.1 Structural steel

Structural steel shall comply with clause 3.1 with proper allowances on strength, resistance to brittle fracture, ductility and weldability.

10.1.2 Concrete

Normal weight concrete shall comply with the recommendations given in HKCC. The nominal maximum size of aggregate shall not exceed 20 mm. In the absence of other information, the wet and the dry densities of reinforced concrete shall be taken as 2450 kg/m³ and 2350 kg/m³ respectively, and the grade specified shall be in the range of C25 to C60. For concrete grades above C60, a performance-based approach based on test and analytical methods should be used to justify the composite behaviour. According to the HKCC, the short-term elastic modulus, E_{cm} (kN/mm²), of the normal weight concrete is given by:

$$E_{cm} = 3.46 \sqrt{f_{cu}} + 3.21 \quad (10.1)$$

where

f_{cu} is the cube compressive strength of concrete (N/mm²).

Table 10.1 - Compressive strength and short-term elastic modulus for various concrete grades

Concrete Grade	Cube compressive strength, f_{cu} (N/mm ²)	Elastic modulus, E_{cm} (kN/mm ²)
C25	25	20.5
C30	30	22.2
C35	35	23.7
C40	40	25.1
C45	45	26.4
C50	50	27.7
C55	55	28.9
C60	60	30.0

For design data on creep coefficient, shrinkage coefficient and coefficient of thermal expansion for concrete, refer to HKCC.

10.1.3 Reinforcement

Reinforcement shall comply with HKCC, and the characteristic strength, f_y , shall not be larger than 500 N/mm². The elastic modulus shall be taken as 205 kN/mm², i.e. same as that of structural steel sections.

Different types of reinforcement may be used in the same structural member.

10.1.4 Shear connectors

Shear connection shall be capable of transmitting longitudinal shear forces between the concrete and the steel section due to factored loads, without causing crushing or other damage to the concrete and without allowing excessive slip or separation between the concrete and the steel section.

10.1.4.1 Headed shear studs

Shear connectors commonly take the form of headed studs welded to the steel section, either directly or through profiled steel sheets. The purpose of the head of the studs is to resist any uplift component of the forces applied to the studs.

The stud material shall be mild steel with the following minimum properties (before cold drawn or cold forging):

Ultimate tensile strength, f_u : 450 N/mm²

Elongation (on a gauge length of $5.65 \sqrt{A_o}$): 15%

where

f_u is the ultimate strength of the stud material,

A_o is the original cross section area.

The minimum diameter and the minimum depth of the head of a headed stud shall be $1.5d$ and $0.4d$ respectively, where d is the nominal shank diameter of the stud.

10.1.4.2 Other types of shear connectors

Other materials may also be used for shear connectors provided that they can be demonstrated to

- i) produce shear connection possessing sufficient deformation capacity as shown in clause 10.3, and
- ii) prevent separation between the concrete and the steel section effectively.

10.1.5 Profiled steel sheets

10.1.5.1 Specification

The steel used to manufacture profiled steel sheets shall have a yield strength between 220 and 550 N/mm².

10.1.5.2 Sheet thickness

The structural thickness of the profiled steel sheets, to which the stresses and section properties apply, is the "bare metal thickness" of the sheets excluding any protective or decorative finish such as zinc coating or organic coating.

The nominal bare metal thickness of the sheets shall not normally be less than 0.70 mm except where the profiled steel sheets are used only as permanent shuttering. Thinner sheets should not be used unless proper justification on their resistance against local damage is provided.

10.2 COMPOSITE BEAMS

10.2.1 General

- (1) This clause presents the design of composite beams with either solid slabs or composite slabs using profiled steel sheet.

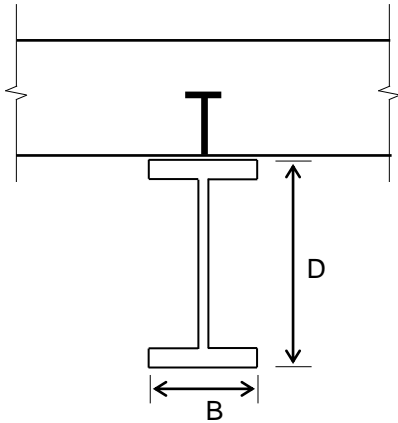

a) Composite beam with solid concrete slab

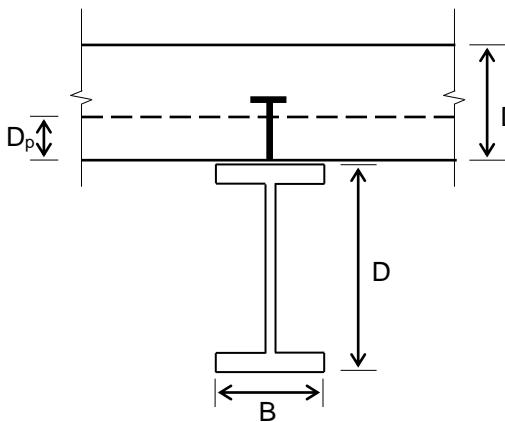

b) Composite beam with composite slab using trapezoidal and re-entrant sheet profiles
(Beam span perpendicular to slab span)

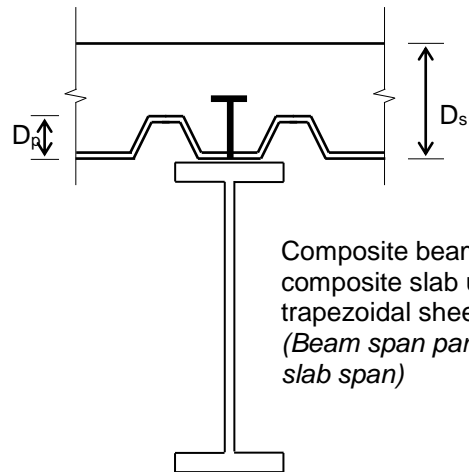

Composite beam with composite slab using trapezoidal sheet profile
(Beam span parallel to slab span)

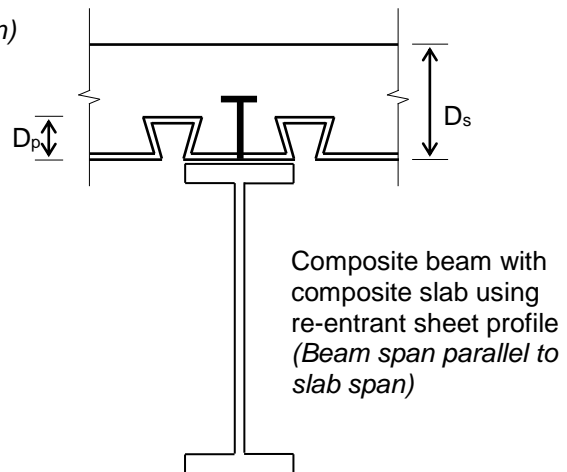

Composite beam with composite slab using re-entrant sheet profile
(Beam span parallel to slab span)

Figure 10.1 - Typical composite beams

- (2) This clause applies to composite beams using steel sections with yield strengths between 235 and 460 N/mm² and C25 to C60 concrete.

The steel sections in the composite beams shall be bi-symmetrical I or H sections. The flanges of the steel sections should be Class 1 plastic, Class 2 compact or Class 3 semi-compact while the webs should be at least Class 3 semi-compact.

- (3) Composite beams shall be checked for
- resistance of critical cross-sections;
 - resistance to lateral-torsional buckling;
 - resistance to shear buckling and transverse forces on webs; and
 - resistance to longitudinal shear.

- (4) Critical cross-section shall include:
- sections under maximum moment;
 - supports;
 - sections subject to concentrated loads or reactions; and
 - places where a sudden change of cross-section occurs, other than a change due to cracking of concrete.

A cross-section with a sudden change in geometry should be considered as a critical cross-section when the ratio of the greater to the lesser resistance moment is greater than 1.2.

- (5) For checking resistance to longitudinal shear, a critical length consists of a length of the interface between two critical cross-sections. For this purpose, critical cross-sections also include:
- free-end of cantilever; and
 - in tapering members, sections so chosen that the ratio of the greater to the lesser plastic resistance moments (under flexural bending of the same direction) for any pair of adjacent cross-sections does not exceed 1.5.

- (6) The concepts “full shear connection” and “partial shear connection” are applicable only to beams in which plastic theory is used for calculating bending resistances of critical cross-sections. A span of beam, or a cantilever, has full shear connection when increase in the number of shear connectors does not increase the design bending resistance of the member. Otherwise, the shear connection is partial.

- (7) Refer to clause 3.1.2 for the design strength of the structural steel section, p_y . The design strengths of the concrete, f_{cd} , and the steel reinforcement, f_{sd} , are given as follows:

$$f_{cd} = f_{cu} / \gamma_c \quad \gamma_c = 1.5 \quad (10.2)$$

$$f_{sd} = f_y / \gamma_s \quad \gamma_s = 1.15 \quad (10.3)$$

where

f_{cu} is the cube compressive strength of concrete;

f_y is the characteristic strength of steel reinforcement; and

γ_c, γ_s are the partial safety factors of concrete and steel reinforcement respectively.

- (8) In unpropped construction, composite beams with Class 1 plastic or Class 2 compact compression steel flanges throughout shall be designed assuming that at the ultimate limit state the whole of the loading acts on the composite beams, provided that the longitudinal shear is calculated accordingly.

Where propped construction is used, all composite beams shall be designed assuming that at the ultimate limit state the whole of the loading acts on the composite beams.

10.2.2 Analysis of internal forces and moments

10.2.2.1 Simply supported or cantilever beams

Elastic analysis shall be used to evaluate both the shear forces and the moments.

10.2.2.2 Continuous beams

The moments in continuous composite beams shall be determined using any of the following methods, provided that the beams comply with the relevant conditions.

- Simplified method (see clause 10.2.2.3)
- Elastic global analysis (see clause 10.2.2.4)
- Plastic global analysis (see clause 10.2.2.5)

All composite beams are assumed to be effectively continuous at all internal supports while the supports are assumed to be simple supports. In each case, the shear forces shall be in equilibrium with the moments and the applied loads.

10.2.2.3 Simplified method

The moments in continuous composite beams shall be determined using the coefficients given in Table 10.2, provided that the following conditions are satisfied.

- In each span, the cross section of the steel beam is uniform with equal flanges and without any haunches.
- The same beam section is used in all spans.
- The dominant loading is uniformly distributed.
- The unfactored imposed load does not exceed 2.5 times the unfactored dead load.
- No span is less than 75% of the longest.
- End spans do not exceed 115% of the length of the adjacent span.
- There is no cantilever.

Table 10.2 - Simplified moment coefficients

Location	Number of spans	Classification of compression flange at supports			
		Class 3 Semi-compact	Class 2 Compact	Class 1 Plastic	
				Generally	Non-reinforced
Middle of end span	2	+0.71	+0.71	+0.75	+0.79
	3 or more	+0.80	+0.80	+0.80	+0.82
First internal support	2	- 0.81	- 0.71	- 0.61	- 0.50
	3 or more	- 0.76	- 0.67	- 0.57	- 0.48
Middle of internal spans	3	+0.51	+0.52	+0.56	+0.63
	4 or more	+0.65	+0.65	+0.65	+0.67
Internal supports except the first	4 or more	- 0.67	- 0.58	- 0.50	- 0.42

Note:

- The coefficients shall be multiplied by the free bending moment $WL/8$, where W is the total factored load on the span L .
- Where the spans in each side of a support differ, the mean of the values of $WL/8$ for the two adjacent spans shall be used to calculate the support moment.
- The values of the coefficients already allow for both pattern loads and possible moment redistribution. No further redistribution shall be carried out when using this method.
- For the use of non-reinforced Class 1 plastic sections, refer to clause 10.2.2.6.

10.2.2.4 Elastic global analysis

- Elastic global analysis of continuous beams shall be carried out using the section properties of the gross uncracked section described in clause 10.2.5.3(2) throughout. The resulting negative moment at any support shall be reduced (except adjacent to cantilevers) by an amount not exceeding the appropriate maximum percentage given in Table 10.3. Corresponding increases shall then be made to the positive moments in the adjacent spans to maintain equilibrium with the applied loads. The shear forces shall also be adjusted, if necessary, to maintain equilibrium.

For beams with unequal spans with over 15% different in lengths, concrete cracking in internal supports with short spans should be properly allowed and designed for.

- (2) Alternatively, provided that the ratios of shorter to longer span are smaller than 0.6, an elastic global analysis shall be carried out assuming that for a length of 15% of the span on each side of internal supports, the section properties are those of the cracked section under negative moments (see clause 10.2.5.3(4)). Elsewhere the section properties of the gross uncracked section are used.

The resulting moments shall be adjusted by an amount not exceeding the appropriate maximum percentage given in Table 10.3. It is also permissible to iteratively adjust the length of span which is assumed to be cracked on each side of an internal support, to correspond to the points of contraflexure determined from the redistributed moment diagram.

Table 10.3 - Maximum redistribution of support moments for elastic global analysis

Elastic global analysis using	Classification of compression flange at supports			
	Class 3 Semi-compact	Class 2 Compact	Class 1 Plastic	
			Generally	Non-reinforced
Gross uncracked section	20%	30%	40%	50%
Cracked section	10%	20%	30%	40%

Note: "Non-reinforced" sections are defined in clause 10.2.2.6.

Imposed loads shall be arranged in the most unfavourable realistic pattern for each case. Dead load γ_f factors shall not be varied when considering such pattern loading, i.e. either 1.0 or 1.4 for all spans.

For continuous beams subject to uniformly distributed imposed load, only the following arrangements of imposed load shall be considered.

- a) Alternate spans loaded
- b) Two adjacent spans loaded

10.2.2.5 *Plastic global analysis*

Plastic global analysis shall be used to determine the moments in continuous beams with non-reinforced Class 1 plastic sections (see clause 10.2.2.6) at internal supports and with Class 1 plastic sections at mid-span, provided that conditions a) to d) given in clause 10.2.2.3 for the simplified method are satisfied.

Alternatively, a plastic global analysis shall be used to determine the moments in continuous beams subject to the following conditions:

- a) Adjacent spans do not differ by more than 33% of the larger span.
- b) End spans do not exceed 115% of the length of the adjacent span.
- c) In any span in which more than half the total factored load on a span is concentrated within a length of one-fifth of the span, the cross section at each positive moment plastic hinge location is such that the plastic neutral axis lies within $0.15(D + D_s)$ below the top of the concrete flange, where D_s is the depth of the concrete flange.
 Note: This condition need not be satisfied where it can be shown that the hinge will be the last to form in that span.
- d) At plastic hinge locations, both the compression flange and the web are Class 1 plastic.

10.2.2.6 *Non-reinforced Class 1 plastic sections*

The recommendations given for non-reinforced Class 1 plastic sections apply exclusively to cross sections with only nominal tension reinforcement in negative moment regions. The nominal tension reinforcement should be neglected when calculating the plastic moment capacity (see clause 10.2.5.1). The classification of both the web and the compression flange shall be Class 1 plastic, in accordance with clause 10.2.4.

10.2.3 Establishment of composite cross-sections

10.2.3.1 Effective span

- (1) The effective span of a beam, L , shall be taken as the distance between the centres of the supports, but not greater than the clear distance between the supports plus the depth of the steel member.
- (2) The effective length of a cantilever shall be taken from the centre of the support, but not greater than the projecting length from the face of the support plus half the depth of the steel member.

10.2.3.2 Effective section

The moment capacity of a composite beam shall be based on the following effective cross section:

- (1) The total effective breadth B_e of the concrete flange (see clause 10.2.3.3) shall be used.
- (2) The effective section of a composite slab which spans onto a beam with its ribs running perpendicular to the beam shall be taken as the concrete above the top of the ribs only. The concrete within the depth of the ribs shall be neglected.

The effective section of a composite slab with its ribs running parallel to the beam shall be taken as the full cross section of the concrete.

The effective section of a composite slab with its ribs running at an angle θ to the beam shall be taken as the full area of the concrete above the top of the ribs plus $\cos^2\theta$ times the area of the concrete within the depth of the ribs. Alternatively, for simplicity, the concrete within the depth of the ribs should conservatively be neglected.

Concrete in tension shall be neglected, and profiled steel sheets shall not be included in the calculation of the effective section.

Reinforcement in compression shall be neglected, unless it is properly restrained by links in accordance with HKCC. Moreover, all welded mesh reinforcement and any bar reinforcement which is less than 10 mm in diameter shall be treated as nominal reinforcement and shall not be included in the calculation of the effective section.

10.2.3.3 Effective breadth of concrete flange

- (1) Allowance shall be made for the in-plane shear flexibility (shear lag) of a concrete flange by using an effective breadth.
- (2) The total effective breadth B_e of concrete flange acting compositely with a steel beam shall be taken as the sum of the effective breadths b_e of the portions of flange each side of the centreline of the steel beam.

In the absence of any more accurate determination, the effective breadth of each portion shall be taken as follows:

- For a slab spanning perpendicular to the beam,
$$b_e = L_z / 8 \leq b \quad (10.4)$$

- For a slab spanning parallel to the beam,
$$b_e = L_z / 8 \leq 0.8b \quad (10.5)$$

where L_z is the distance between points of zero moment.

However, if a separate allowance is made for the co-existing effects of slab bending,

$$b_e = L_z / 8 \leq b \quad (10.6)$$

- For a simply supported beam, L_z is equal to the effective span L (see clause 10.2.3.1)
- For a continuous beam, L_z should be obtained from Figure 10.2.

- (3) The actual breadth b of each portion shall be taken as half the distance to the adjacent beam, measured to the centreline of the web, except that at a free edge the actual breadth is the distance from the beam to the free edge; refer to Figure 10.2.

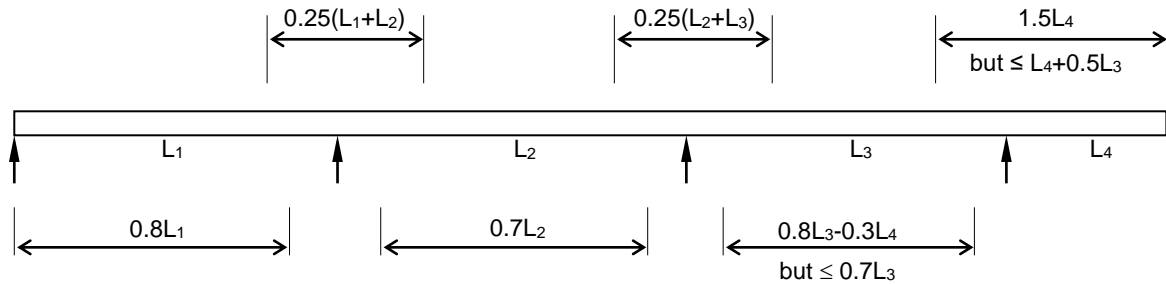

Figure 10.2 - Value of L_z for continuous beams

10.2.3.4 Modular ratio

- (1) The elastic section properties of a composite cross-section shall be expressed in terms of an equivalent steel section by dividing the contributions of the concrete flange by the effective modular ratio, α_e .

In the absence of detailed information about the effective modular ratio, α_e , the following expression shall be adopted:

$$\alpha_e = \alpha_s + \rho_L (\alpha_L - \alpha_s) \quad (10.7)$$

where

α_L is the modular ratio for long-term loading;

α_s is the modular ratio for short-term loading;

ρ_L is the proportion of the total loading which is long term.

The values of short-term and long-term modular ratios in Table 10.4 shall be used for all grades of concrete.

Table 10.4 - Modular ratios for normal weight concrete

Modular ratio for short-term loading α_s	Modular ratio for long-term loading α_L
8	22

Refer to clause 3.1 of HKCC for detailed information on the long-term deformation of concrete due to creep and drying shrinkage.

- (2) Storage loads and loads which are permanent in nature shall be taken as long term. Imposed roof loads, wind loads and snow loads shall be treated as short term.
- (3) For the purpose of determining the modular ratio, all spans are assumed to be fully loaded.
- (4) In the absence of detailed information about the nature of imposed loads, imposed loads on floors shall be assumed to be two-third short-term and one-third long-term in general.

10.2.4 Classification of composite cross-sections

- (1) General
The capacities of composite cross sections shall be limited by local buckling in the steel web or in the steel compression flange. In the absence of a more refined calculation, the design method given in clause 10.2.6 shall be adopted.

In calculations for the construction stage of a composite beam based on the plain steel section, the classification of cross sections shall be in accordance with section 7.

(2) Classification limits

To classify a composite cross section, the position of the neutral axis shall be based on the effective cross section determined in accordance with clause 10.2.3.2.

When the concrete flange is in tension, the flange reinforcement should be included in the calculation of the effective section if utilized in the design of the member.

Classification of composite cross sections shall be determined according to Tables 10.5 and 10.6.

Table 10.5 - Limiting width to thickness ratios for flanges and webs in composite sections

(Elements which exceed these limits are to be taken as Class 4 slender)

Type of element		Class of section		
		Class 1 Plastic	Class 2 Compact	Class 3 Semi-compact
Outstand element of compression flange, b / T	Rolled section	9ϵ	10ϵ	15ϵ
	Welded section	8ϵ	9ϵ	13ϵ
Web, d / t	With neutral axis at mid-depth	80ϵ	100ϵ	120ϵ
	Generally	$\frac{64 \epsilon}{1+r}$	$\frac{76 \epsilon}{1+r}$	See Table 10.6

Table 10.6 - Limiting width to thickness ratios for semi-compact webs

(Elements which exceed these limits are to be taken as Class 4 slender)

Web, generally	Class 3 Semi-compact
$r \geq 0.66$	$\frac{114 \epsilon}{1+2r}$ for rolled sections $\left(\frac{41}{r} - 13\right) \epsilon$ for welded sections
$0.66 > r \geq 0$	$\frac{114 \epsilon}{1+2r}$
$0 > r$	$\frac{114 \epsilon (1+r)}{\frac{3}{2}(1+2r)}$

Notes:

- 1) These ratios apply to composite sections. During construction, the classification in section 7 applies.
- 2) Check webs for shear buckling with section 8 when $d / t \geq 63 \epsilon$.
- 3) The values in this table do not apply to T sections.
- 4) $\epsilon = \sqrt{275 / p_y}$
- 5) r is the ratio of the mean longitudinal stress in the web to the design strength p_y , compressive stresses being taken as positive and tensile stresses as negative (see Figure 10.3).

Assumed plastic stress distribution in web

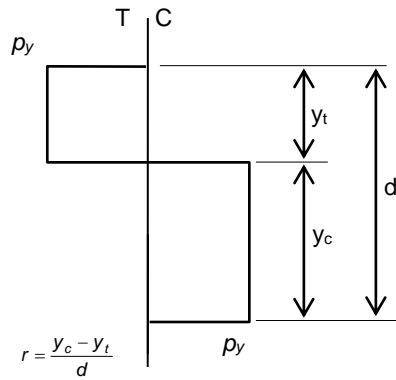

Assumed elastic stress distribution in web

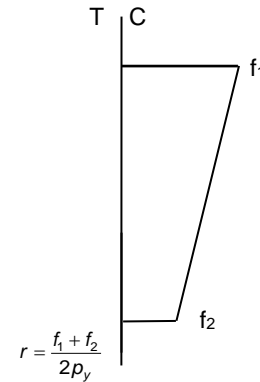

a) Section with Class 1 plastic or Class 2 compact compression flange

b) Section with Class 3 semi-compact compression flange

Figure 10.3 - Determination of web stress ratio r

The value of r is given by:

$$r = -\frac{F_c}{R_w} \quad \text{but} \quad r \geq -1 \quad \text{for positive moment} \quad (10.8a)$$

$$= -\frac{R_r}{R_w} \quad \text{but} \quad r \leq -1 \quad \text{for negative moment} \quad (10.8b)$$

where

F_c is the compressive force in the concrete flange;

R_r is the resistance of the reinforcement equal to $f_{sd} A_r$;

R_w is the resistance of the clear web depth equal to $d t p_y$;

In the case of partial shear connection, reference shall also be made to clause 10.3.3.2(2).

(3) Enhancement due to attachments

a) A steel compression flange restrained by effective attachment to a solid concrete flange by shear connectors in accordance with clause 10.3 shall be considered as Class 1 plastic.

b) Where a steel compression flange is restrained by effective attachment by shear connectors in accordance with clause 10.3 to a composite slab in which either:

- the ribs run at an angle of at least 45° to the axis of the beam; or
- the breadth b_r (as defined in clause 10.3, measured perpendicular to the axis of the rib) of the rib located directly over the beam is not less than half the breadth of the beam flange;

then the classification of the compression flange shall be considered as:

- Class 1 plastic if its classification in accordance with Table 10.5 is Class 2 compact; or
- Class 2 compact if its classification in accordance with Table 10.5 is Class 3 semi-compact.

10.2.5 Section capacities and properties of composite cross-sections

(1) The moment capacities of composite cross-sections shall be determined by rigid-plastic theory only where the effective composite cross-sections is Class 1 plastic or Class 2 compact, and where no pre-stressing by tendons is used.

The rigid-plastic theory is also applicable to a composite cross-section with a steel section of Class 1 or Class 2 flanges but a Class 3 semi-compact web

provided that the depth of web taken as effective in resisting compression is reduced according to clause 10.2.5.2.

- (2) Elastic analysis and non-linear theory for moment capacities shall be applied to cross-sections of any class.
- (3) For elastic analysis and non-linear theory, it shall be assumed that the composite cross-section remains plane after bending if the shear connection and the transverse reinforcement are designed in accordance with clause 10.3, considering appropriate distributions of design longitudinal shear forces.
- (4) The tensile strength of concrete shall be neglected.
- (5) Where the steel section of a composite member is curved in plan, the effects of curvature should be taken into account.
- (6) For composite cross-sections using steel sections with yield strengths larger than 420 N/mm² but less than 460 N/mm², where the distance y_{pl} between the plastic neutral axis and the extreme fibre of the concrete flange in compression exceeds 15% of the overall depth h of the composite cross-section (i.e. depth of steel beam plus depth of concrete flange), the design resistance moment M_c should be taken as βM_c where β is a reduction factor given by

$$\beta = 1 \quad \text{when } y_{pl}/h \leq 0.15 \quad (10.9a)$$

$$= 0.85 \quad \text{when } y_{pl}/h = 0.4 \quad (10.9b)$$

Linear interpolation is permitted for β when y_{pl}/h is within the range of 0.15 to 0.4.

- (7) Plastic moment resistance of composite cross-section with partial shear connection.
 - a) In regions of sagging bending, partial shear connection in accordance with clause 10.3 shall be used in composite beams for buildings.
 - b) Unless otherwise verified, the plastic moment capacity in hogging bending shall be determined in accordance with clause 10.2.5.1, and full shear connection should be provided to ensure yielding of reinforcement in tension, i.e. partial shear connection is not permitted.
 - c) Where ductile shear connectors are used, the moment capacity of the critical cross-section of the composite beam, M_c , shall be calculated by means of rigid plastic theory in accordance with clause 10.2.5.1, except that a reduced value of the compressive force in the concrete flange R_q should be used in place of R_c when $R_c < R_s$, or in place of R_s when $R_c > R_s$, where

$$\begin{aligned} R_c &= \text{Resistance of concrete flange} \\ &= 0.45 f_{cu} B_e (D_s - D_p) \end{aligned} \quad (10.10)$$

$$\begin{aligned} R_s &= \text{Resistance of steel beam} \\ &= A p_y \end{aligned} \quad (10.11)$$

$$\begin{aligned} R_q &= \text{Resistance of shear connection} \\ &= N P \end{aligned} \quad (10.12)$$

where

N is the number of shear connectors from the point of zero moment to the point of maximum moment.

$P = P_p$ is the design resistance of shear connectors given in clause 10.3.2

The degree of shear connection, k_{sc} , is given by:

$$k_{sc} = \frac{R_q}{R_s} \quad \text{when } R_s < R_c \quad \text{or} \quad (10.13a)$$

$$= \frac{R_q}{R_c} \quad \text{when } R_s > R_c \quad (10.13b)$$

The location of the plastic neutral axis in the slab shall be determined with R_q . It should be noted that there is a second plastic neutral axis within the steel section, which should be used for the classification of the steel web.

- d) The plastic moment capacity of the composite cross-section with partial shear connection, M_{co} , may be determined conservatively as follows:

$$M_{co} = M_s + k_{sc} (M_c - M_s) \quad (10.14)$$

where

- M_c = moment capacity of composite section
 M_s = moment capacity of steel section
 k_{sc} = degree of shear connection

- e) For composite beams under sagging moment, the following limit on the minimum degree of shear connection applies, but not less than 0.4:

For span L_e up to 25 m,

$$k_{sc} \geq 1 - \left(\frac{355}{p_y} \right) (0.75 - 0.03 L_e) \quad (10.15a)$$

For L_e exceed 25 m,

$$k_{sc} = 1 \quad (10.15b)$$

where L_e is the distance in sagging moment between points of zero moment in meters.

10.2.5.1 Plastic moment capacity

The plastic moment capacity of a composite cross section with Class 1 or Class 2 flanges and webs shall be calculated on the following basis.

- (1) Concrete is stressed to a uniform compression of $0.45 f_{cu}$ over the full depth of concrete on the compression side of the plastic neutral axis.
- (2) The structural steel section is stressed to its design strength p_y either in tension or in compression.
- (3) Longitudinal reinforcement is stressed to its design strength f_{sd} where it is in tension.

10.2.5.2 Reduced plastic moment capacity

The reduced plastic moment capacity of a composite beam with Class 1 or Class 2 steel compression flanges but with a Class 3 semi-compact steel web shall be determined using the reduced section shown in Figure 10.4.

The depth of steel web taken as effective in resisting compression shall be limited to $19 t \epsilon$ adjacent to the compression steel flange and $19 t \epsilon$ adjacent to the plastic neutral axis. The remainder of the steel web on the compression side of the plastic neutral axis shall be neglected.

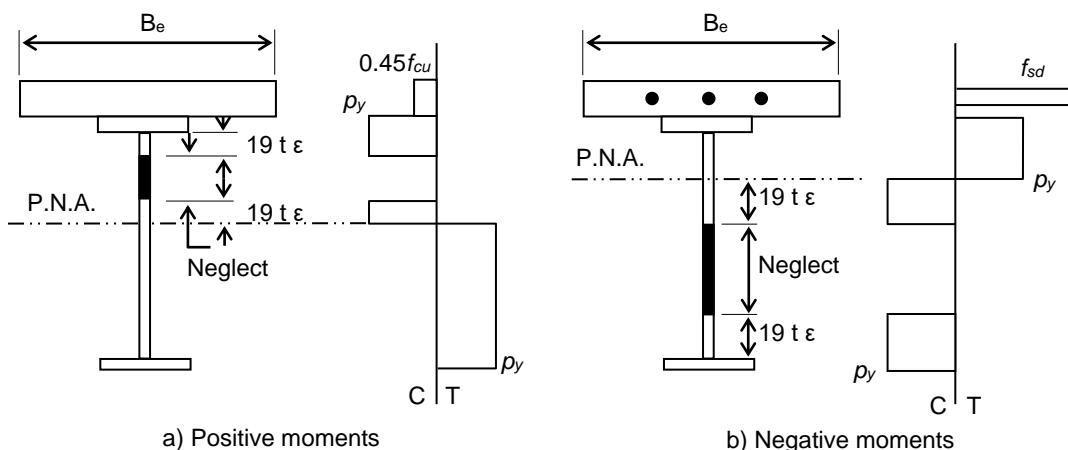

NOTE: P.N.A. denotes plastic neutral axis of effective section

Figure 10.4 - Reduced section

10.2.5.3 *Second moment of area and elastic section modulus*

- (1) For composite beams, three possible values of the second moment of area should be distinguished:

I_g for the gross section, i.e. uncracked section;
 I_p for the cracked section value under positive moments; and
 I_n for the cracked section value under negative moments.

The appropriate value of the second moment of area should be used as follows:

- a) I_g for elastic global analysis with gross uncracked section method (see clause 10.2.2.4(1));
- b) I_g and I_n for elastic global analysis with cracked section method (see clause 10.2.2.4(2));
- c) I_g , I_p or I_n for elastic section modulus (see clause 10.2.5.3(5)), as appropriate;
- d) I_g for deflection calculations (see clause 10.2.7.1).
- (2) Gross uncracked section, I_g
The gross value of the second moment area of the uncracked composite section I_g shall be calculated using the mid-span effective breadth of the concrete flange with concrete flange uncracked but unreinforced. The full area of concrete within the effective breadth of the concrete flange shall be included in the effective section.

Alternatively, the concrete within the depth of the ribs shall conservatively be neglected for simplicity. Any concrete beam casing shall be neglected.
- (3) Cracked section under positive moments, I_p
For positive moments, the second moment of area of the cracked composite section shall be calculated using the mid-span effective breadth of the concrete flange but neglecting any concrete in tension.
- (4) Cracked section under negative moments, I_n
For negative moments, the second moment of area of the cracked composite section shall be calculated using a section comprising the steel section together with the effectively anchored reinforcement located within the effective breadth of the concrete flange at the support.
- (5) Elastic section modulus
In determining stresses at the serviceability limit state, the elastic section modulus of a composite section shall be determined from the appropriate value of the second moment of area as follows:
- a) For positive moments:
 I_g if the elastic neutral axis is located within the steel section;
 I_p if the elastic neutral axis is located within the concrete flange.
- b) For negative moments:
 I_n .

10.2.6 **Ultimate limit state design**

10.2.6.1 *Moment capacities*

- (1) Simply supported beams
The moment capacity of simply supported composite beams with steel sections of Class 1 plastic or Class 2 compact compression flanges subject to positive moment shall be taken as the plastic moment capacities of the composite sections, provided that the webs are not Class 4 slender. If the web is Class 1 plastic or Class 2 compact, the plastic moment capacity in clause 10.2.5.1 should be used. If the web is Class 3 semi-compact, the reduced plastic moment capacity in clause 10.2.5.2 should be used.
- (2) Cantilevers
The moment capacity of cantilever composite beams shall be based on the steel sections together with any effectively anchored tension reinforcement within the effective breadth of the concrete flanges. However, tension reinforcement which

is provided to reinforce the slabs for moments due to loading acting directly on them should not be included.

When the compression flange is Class 1 plastic or Class 2 compact, the moment capacity should be taken as the plastic moment capacity, provided that the web is not Class 4 slender. If the web is Class 1 plastic or Class 2 compact, the plastic moment capacity in clause 10.2.5.1 should be used. If the web is Class 3 semi-compact, the reduced plastic moment capacity in clause 10.2.5.2 should be used.

(3) Continuous beams

The positive moment capacity of continuous beams shall be determined as for simply supported beams (see clause 10.2.6.1(1)) and the negative moment capacities shall be determined as for cantilevers (see clause 10.2.6.1(2)).

10.2.6.2 *Shear capacities*

The steel beams shall be conservatively designed in accordance with Section 8 to resist the whole of the vertical shear force.

10.2.6.3 *Combined bending and shear*

The reduction of moment capacity due to high shear force shall be determined as follows:

$$M_{cv} = M_c - \rho (M_c - M_f) \quad \text{when } V \geq 0.5 V_c \quad (10.16)$$

where

M_{cv} is the reduced plastic moment capacity of the composite cross-section under high shear force;

M_c is the plastic moment capacity of the composite cross-section;

M_f is the plastic moment capacity of that part of the section remaining after deduction of the shear area A_v defined in section 8;

$$\rho = \left(\frac{2V}{V_c} - 1 \right)^2$$

V is the shear force;

V_c is the lesser of the shear capacity and the shear buckling resistance, both determined from section 8.

For a composite cross-section with a web of Class 3 semi-compact, M_c is the reduced plastic moment capacity to clause 10.2.5.2.

Alternatively, the influence of transverse shear force shall be taken into account through a reduced design strength $(1 - \rho) p_y$ in the shear area A_v of the steel section to clause 8.2.1.

In all cases, the shear force F_v should not exceed the shear capacity of the steel section determined according to clause 8.2.1.

10.2.6.4 *Stability of compression flanges*

- (1) The stability of the bottom flanges in continuous beams shall be checked for each span in turn.

The span being checked shall be assumed to be loaded with factored dead load only and the negative moments at each internal support shall be assumed to be equal to the relevant moment capacity M_c (elastic, plastic or reduced plastic) applicable for design of the composite cross-section at the support (see Figure 10.5).

However, the support moments shall be taken as more than those obtained from an elastic analysis (using the properties of the gross uncracked section) without redistribution.

- (2) To prevent lateral-torsional buckling, the compression flanges should be laterally restrained as recommended in section 8. When checking the lateral stability of the bottom flanges in negative moment regions, the methods given in clause 8.3 should be used.

Alternatively, other methods that include allowances for the torsional restraint provided by the concrete slab should also be used.

- (3) At plastic hinge locations, other than the last hinge to form in each span, the recommendations for plastic hinge locations given in section 8 shall be followed.

Where the reduction of negative moments as described in elastic global analysis using the gross section method exceeds 30% at the supports of beams of uniform section (or 20% when using the cracked section method), the points of support shall be treated as plastic hinge locations.

In beams of varying section, the locations of the potential negative moment plastic hinges, implied by the redistribution of support moments, should be identified. When the reduction of negative moments at such locations exceeds 30% in elastic global analysis using the gross section method (or 20% when using the cracked section method), they should be treated as active plastic hinge locations.

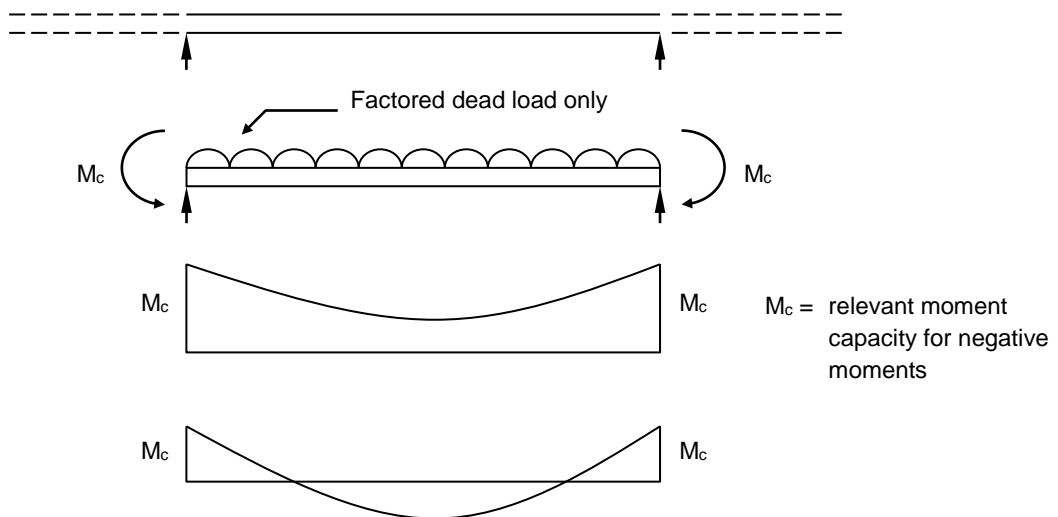

Figure 10.5 - Lateral buckling of bottom flanges in continuous composite beams

10.2.7 Serviceability limit state design

10.2.7.1 Deflection

- (1) General
The deflection under serviceability loads of a building or part shall not impair the strength or efficiency of the structure or its components or cause damage to the finishing. Deflections shall be determined under serviceability loads.
- (2) Deflection of a composite beam at the construction stage due to the dead load of the concrete flange and the steel beam should be limited when unpropped construction is used. Precambering in the steel beam may be adopted to reduce the deflection of the composite beam under the self-weights of the steel beam and the concrete flange.
- (3) For unpropped construction, the imposed load deflection shall be based on the properties of the composite cross-section but the dead load deflection, due to the self-weights of the steel beam and the concrete flange, shall be based on the properties of the steel beam.
- (4) For propped construction, all deflections shall be based on the properties of the composite cross-section. When calculating deflections, the behaviour of composite beams shall be taken as linear elastic, except for the redistribution of moments recommended in clause 10.2.7.1(6) and the increased deflections for partial shear connection recommended in clause 10.2.7.1(6e).
- (5) Simply supported beams
Deflections of simply supported composite beams shall be calculated using the properties of the gross uncracked section described in clause 10.2.5.3(2).

(6) Continuous beams

For continuous beams, the imposed load deflections shall allow for the effects of pattern loading. Where design at the ultimate limit state is based on plastic global analysis or on an analysis involving significant redistribution of support moments, the effects of shakedown on deflections should also be included in the imposed load deflections.

As an alternative to rigorous analysis, the following methods should be used to allow for the effects of pattern loading and shakedown by modifying the initial support moments.

a) Allowance for pattern loading

The initial moments at each support shall be determined for the case of unfactored imposed load on all spans. Reductions shall then be made to these initial support moments (except adjacent to cantilevers) to allow for pattern loading, as follows:

- for normal loading type: 30%
- for storage loading type: 50%

b) Allowance for shakedown effects

Allowance shall be made for the effects of shakedown if the beam has been designed for the ultimate limit state using:

- plastic global analysis (see clause 10.2.2.5);
- elastic global analysis, using the properties of the gross uncracked section (see clause 10.2.2.4(1)) with redistribution exceeding 40%;
- elastic global analysis, using the properties of the cracked section (see clause 10.2.2.4(2)) with redistribution exceeding 20%.

The support moments shall be determined, without any redistribution, for the following combination of unfactored loads:

- for normal loading type: dead load plus 80% of imposed load;
- for storage loading type: dead load plus 100% of imposed load.

Where these support moments exceed the plastic moment capacity of the section for negative moments, the excess moments should be taken as the moments due to shakedown.

The deflections produced by these shakedown moments shall be added to the imposed load deflections. This shall be done by further reducing the calculated support moments due to imposed loading, by values equal to the shakedown moments, in addition to the reductions for the effects of pattern loading.

c) Calculation of moments

The support moments shall be based on an analysis using the properties of the gross uncracked section throughout.

Alternatively, provided the conditions given in clause 10.2.2.3 for the simplified method are satisfied, the support moments should be taken as follows:

- two-span beam: $WL/8$;
- first support in a multi-span beam: $WL/10$;
- other internal supports: $WL/14$.

In these expressions, W is the appropriate unfactored load on the span L . Where the spans in each side of a support differ, the mean of the values of WL for the two adjacent spans should be used.

d) Calculation of deflections

The imposed load deflection in each span shall be based on the loads applied to the span and the support moments for that span, modified as recommended to allow for pattern loading and shakedown effects.

Provided that the steel beam is of uniform section without any haunches, the properties of the gross uncracked composite section should be used throughout.

The dead load deflections shall be based on an elastic analysis of the beam. For unpropped construction, the properties of the steel beam should be used. For propped construction, the properties of the gross uncracked composite section should be used.

For continuous beams under uniform load or symmetric point loads, the deflection δ_c at mid-span is given by:

$$\delta_c = \delta_o \left[1 - 0.6 \frac{M_1 + M_2}{M_o} \right] \quad (10.17)$$

where

- δ_o is the deflection of a simply supported beam for the same loading;
- M_o is the maximum moment in the simply supported beam;
- M_1 and M_2 are the moments at the adjacent supports (modified as appropriate).

e) Partial shear connection

The increased deflection under serviceability loads arising from partial shear connection is given by:

- For propped construction

$$\delta = \delta_c + 0.5 (1 - k_{sc}) (\delta_s - \delta_c) \quad (10.18a)$$

- For unpropped construction

$$\delta = \delta_c + 0.3 (1 - k_{sc}) (\delta_s - \delta_c) \quad (10.18b)$$

where

- k_{sc} is the degree of shear connection defined in clause 10.2.5 (7c);
- δ_s is the deflection for the steel beam acting alone;
- δ_c is the deflection of a composite beam with full shear connection for the same loading.

For continuous beams, the same formulae apply, but δ_s and δ_c refer to the deflection of the continuous beam, δ_c being calculated as recommended in clause 10.2.7.1(6d).

10.2.7.2 Irreversible deformation and check against stresses

- (1) To prevent gross deformations under normal service conditions, irreversible deformations should be avoided in simply supported beams, cantilevers, and in the mid-span regions of continuous beams.

The stresses based on the elastic properties of the section shall be calculated under serviceability loading. It is not necessary to modify the elastic section modulus to take into account partial shear connection at the serviceability limit state.

- (2) In simply supported beams and cantilevers and the mid-span regions of continuous beams, the stresses in the extreme fibre of the steel beam shall not exceed the design strength p_y and the stress in the concrete flange shall not exceed $0.5 f_{cu}$.
- (3) It is not necessary to limit the stresses over the supports of continuous beams, provided that the recommendations given in clause 10.2.7.1(6) are followed.

It should be noted that it is normally not necessary to calculate stresses in unpropped composite beams with symmetric cross sections whenever the unfactored imposed load is larger than the unfactored dead load.

10.2.7.3 *Cracking*

- (1) Where it is required to limit the crack width, reference shall be made to HKCC. Where environmental conditions will not give rise to corrosion, such as in heated office buildings, it is not normally necessary to check crack widths in the design of composite beams, even where the composite beams are designed as simply supported, provided that the concrete flange slab is reinforced as recommended to reduce concrete cracking to HKCC.
- (2) In cases of exposure to adverse environmental conditions (such as floors in car-parking structures or roofs generally) additional reinforcement in the concrete flange over the beam supports shall be provided to control cracking and the relevant clauses in HKCC shall be referred to. To avoid visible cracks where hard finishes are used, the use of crack control joints in the finishes should be considered.
- (3) In general, nominal reinforcement with a cross sectional area of 0.2% of the cross section of the concrete slab over the profiled steel sheets shall be provided in unpropped composite slab construction.

In propped composite slab construction or situations where cracking may be visually important, the nominal reinforcement should be increased to 0.4% of the corresponding cross sectional area of the concrete slab.

10.2.7.4 *Vibration*

Where vibration may cause discomfort to the occupants of a building or damage to its contents, the response of long-span composite floors should be considered and complied with clause 5.4.

10.3 SHEAR CONNECTION

10.3.1 General

The shear connection shall be capable of transmitting the longitudinal shear force between the concrete and the steel section due to factored loads, without causing crushing or other damage to the concrete and without allowing excessive slip or separation between the concrete and the steel section.

Shear connectors shall be provided along the entire length of composite beams to transmit the longitudinal shear force between the concrete slab and the steel beam. Moreover, transverse reinforcements shall also be provided along the entire length of composite beams to prevent longitudinal shear failure and splitting of concrete slab due to concentrated forces applied by the shear connectors.

10.3.2 Design resistance of shear connectors

10.3.2.1 General

In a solid slab, the design resistance of shear connectors against longitudinal shear is given by:

$$a) \quad \text{For positive moments, } P_p = 0.8 P_k \quad (10.19a)$$

$$b) \quad \text{For negative moments, } P_n = 0.6 P_k \quad (10.19b)$$

where

P_k is the characteristic resistance of the shear connector.

The characteristic resistance for a headed stud shall be obtained by reference to clause 10.3.2.2. As values are not at present given in this Code for types of shear connector other than headed studs, the characteristic resistances of other types of shear connector shall be determined from push out tests.

10.3.2.2 Headed shear studs in solid slabs

The characteristic resistance P_k of a headed shear stud with the dimensions and properties given in clause 10.1.4.1 embedded in a solid slab of normal weight concrete shall be taken from Table 10.7.

Table 10.7 - Characteristic resistance P_k of headed shear studs in normal weight concrete

Characteristic resistance of headed shear studs P_k (kN)									
Dimensions of headed shear stud	Cube compressive strength of concrete, f_{cu} (N/mm ²)								
	Minimum as-welded height (mm)	C25	C30	C35	C40	C45	C50	C55	C60
25	100	116.1	133.1	147.6	162.4	176.7	176.7	176.7	176.7
22	88	89.9	102.4	114.3	125.8	136.8	136.8	136.8	136.8
19	76	67.1	76.3	85.3	93.8	102.1	102.1	102.1	102.1
16	64	47.5	54.2	60.5	66.5	72.4	72.4	72.4	72.4

Note: For cube compressive strength of concrete greater than 60 N/mm², the values of P_k should be taken as those with f_{cu} and E_{cm} limiting to those of concrete grade C60.

The characteristic resistance of headed shear studs, P_k , is given by:

$$P_k = 0.29 d^2 \alpha \sqrt{0.8 f_{cu} E_{cm}} \leq 0.8 f_u \left(\frac{\pi d^2}{4} \right) \quad (10.20)$$

where

d = diameter of headed shear studs, 16 mm $\leq d \leq$ 25 mm

$$\alpha = 0.2 \left(\frac{h}{d} + 1 \right) \quad \text{for } 3 \leq \frac{h}{d} \leq 4$$

$$= 1 \quad \text{for } \frac{h}{d} > 4$$

- h = overall height of headed shear studs;
 f_{cu} = cube compressive strength of concrete;
 E_{cm} = elastic modulus of concrete from clause 10.1.2 according to HKCC;
 f_u = ultimate tensile strength of stud material before cold-drawn (or cold-forging) which is taken conservatively as 450 N/mm² according to clause 10.1.4.1.

10.3.2.3 Headed shear studs with profiled steel sheets

(1) General

The recommendations of this clause apply to headed shear studs with the dimensions and properties given in clause 10.1.4.1, embedded in slabs comprising profiled steel sheets and concrete. These recommendations apply only when all the following conditions are satisfied.

- The overall depth of the profiled steel sheet is not less than 35 mm nor greater than 80 mm.
- The mean width of the troughs of the profiled steel sheet is not less than 50 mm.
- The height of the headed shear studs is at least 35 mm greater than the overall depth of the profiled steel sheet.

(2) Ribs perpendicular to the beam

The capacity of headed shear studs in composite slabs with the ribs running perpendicular to the beam shall be taken as their capacity in a solid slab (see clause 10.3.2.1) multiplied by the shape correction factor k given by the following expressions:

$$\text{for 1 stud per rib: } k = 0.7 \frac{b_r}{D_p} \left(\frac{h}{D_p} - 1 \right) \leq 1.0 \quad (10.21)$$

$$\text{for 2 studs or more per rib: } k = 0.5 \frac{b_r}{D_p} \left(\frac{h}{D_p} - 1 \right) \leq 0.8 \quad (10.22)$$

where

b_r is the average width of the concrete rib for trapezoidal profiles or the minimum width for re-entrant profile as defined in clause 10.3.2.3 (6);

D_p is the overall depth of the profiled steel sheet;

h is the overall height of the headed shear stud, and it should not be taken as more than $2D_p$ or $D_p + 75$ mm, whichever is less, although studs of greater height may be used.

(3) Ribs parallel to the beam

The capacity of headed shear studs in composite slabs with the ribs running parallel to the beam shall be taken as their capacity in a solid slab (see clause 10.3.2.1) multiplied by the shape correction factor k given by the following expression:

$$k = 0.6 \frac{b_r}{D_p} \left(\frac{h}{D_p} - 1 \right) \leq 1.0 \quad (10.23)$$

where

b_r , D_p and h are as in clause 10.3.2.3.

Where there is more than one longitudinal line of studs in a concrete rib, the mean width b_a of the trough of the profiled steel sheet should be at least 50 mm greater than the transverse spacing of the lines of studs.

Optionally, the trough of the profiled steel sheet may be split longitudinally and separated to form a wider concrete rib over the flange of the steel beam and, in this case, b_r should also be increased accordingly in the expression for k given above.

(4) Ribs running at an angle to the beam

Where the ribs run at an angle θ to the beam, the shape correction factor k should be determined from the expression:

$$k = k_1 \sin^2\theta + k_2 \cos^2\theta \quad (10.24)$$

where

k_1 is the value of k from clause 10.3.2.3 (2);
 k_2 is the value of k from clause 10.3.2.3 (3).
 Alternatively, the smaller value of k_1 and k_2 shall be used.

- (5) Upper limits for the shape correction factor k
 In the absence of suitable test data, the shape correction factor k should be taken as the appropriate values given in Table 10.8.

Table 10.8 - Upper limit for k

Condition	Number of headed shear studs per rib	Thickness of profiled steel sheet (mm)	Upper limit for k
'Welded-through' profiled steel sheet with $d \leq 20$	1	≤ 1.0 > 1.0	0.85 1.0
	2	≤ 1.0 > 1.0	0.7 0.8
Profiled steel sheet with pre-formed holes using $d = 19$ and 22 only	1	0.75 to 1.5	0.75
	2	0.75 to 1.5	0.60

Note: d denotes diameter of headed shear studs (mm).

- (6) Trough width
 Provided that the headed shear studs are located centrally in the rib, b_r shall be taken as the mean width of the trough b_a for trapezoidal profiled steel sheet, but equal to the minimum width of the trough b_b for re-entrant profiled steel sheet (see Figure 10.6).

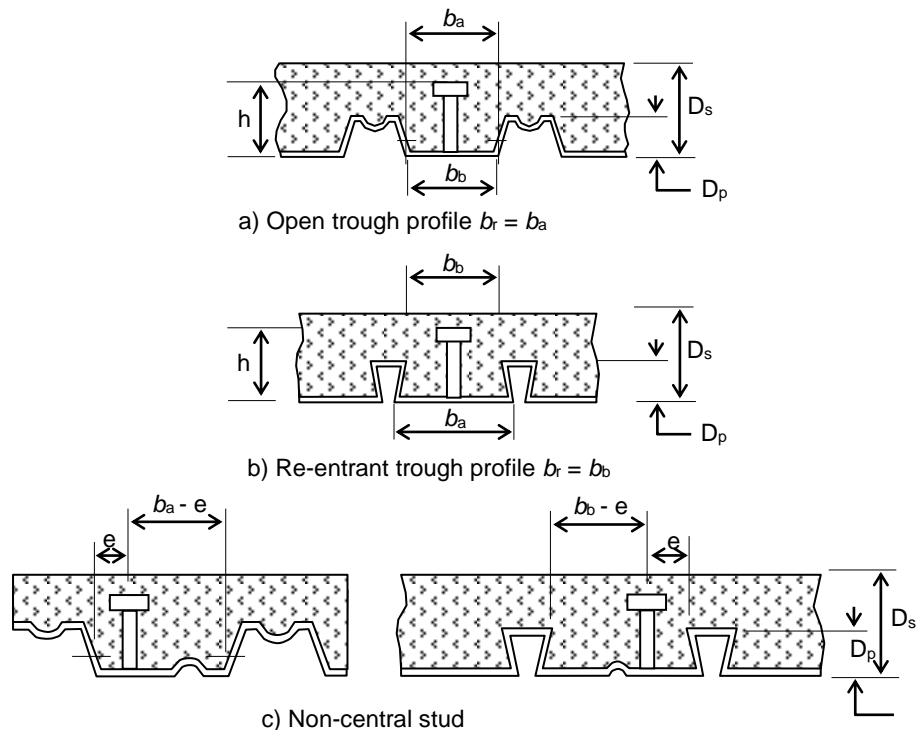

Figure 10.6 - Breadth of concrete rib, b_r

Where it is necessary for the headed shear studs to be located noncentrally in the rib, the studs should preferably be placed in the favourable location such that the zone of concrete in compression in front of the stud is maximized. Where it is necessary for the headed shear studs to be placed in the unfavourable location, b_r should be reduced to $2e$, where e is the distance to the nearer side of the rib (see Figure 10.6). The distance e shall be not less than 25 mm.

Where the headed shear studs are placed in pairs but in an off-set pattern alternately on the favourable and unfavourable sides (subject to the minimum spacings given in clause 10.3.4.1), b_r should be determined as for centrally located studs.

10.3.3 Provision of shear connectors

10.3.3.1 Full shear connection

(1) Positive moments

For full shear connection, the number of shear connectors N_p , required to develop the positive moment capacity of the section, i.e. the number of shear connectors required to be provided along each side of the point of maximum moment (see clause 10.3.3.3), is given by:

$$N_p P_p \geq F_p \quad (10.25)$$

where

P_p is the design resistance of the shear connector in positive moment regions obtained from clause 10.3.2.1;

F_p is the longitudinal compressive force in the concrete slab at the point of maximum positive moment. It is equal to the lesser of the resistances of steel section and the concrete flange when the design is based on the plastic moment capacity of the composite section, or it is determined from the calculated stresses in the concrete slab when the design is based on the elastic moment capacity of the composite section.

(2) Negative moments

For full shear connection, the number of shear connectors N_n , required to develop the negative moment capacity of the section, i.e. the number of shear connectors required to be provided along each side of the point of maximum moment (see clause 10.3.3.3), is given by:

$$N_n P_n \geq F_n \quad (10.26)$$

where

P_n is the design resistance of the shear connector in negative moment regions obtained from clause 10.3.2.1;

F_n is the resistance of longitudinal reinforcement located within the effective cross section.

The number of shear connectors provided to develop the negative moment capacity shall not be reduced below N_n . This also applies where the elastic moment capacity is used.

10.3.3.2 Partial shear connection

(1) Conditions

This method should be used only when the shear connectors are headed shear studs with the dimensions and properties given in clause 10.1.4.1 or other types of shear connectors which have at least the same deformation capacity as headed shear studs. The spacing of the shear connectors should satisfy the recommendations given in clause 10.3.3.3.

(2) Number of shear connectors

Where the maximum positive moment in a span is less than the plastic moment capacity of the composite section, calculated on the basis given in clause 10.2 as appropriate, the actual number of shear connectors N_a shall be reduced below N_p , the number required for full shear connection, as given in clause 10.3.3.1.

No reduction shall be made in the number of shear connectors N_n required for full shear connection for negative moments.

The reduced plastic moment capacity of the composite section shall be calculated assuming a reduced value of the compressive force F_c in the concrete flange equal to the resistance of the shear connection R_q as follows:

$$N_a P_p = R_q = F_c \quad (10.27)$$

The classification of the web (see clause 10.2) should be based on the value of the ratio r determined assuming that the compressive force F_c in the concrete flange is equal to R_q .

10.3.3.3 Spacing of shear connectors

(1) Conditions

The total number of shear connectors between a point of maximum positive moment and each adjacent support shall not be less than the sum of N_p and N_n , obtained from clause 10.3.3.1.

All the shear connectors should be spaced uniformly along the beam, provided that the recommendations on spacing in clauses 10.3.3.3(2) to 10.3.3.3(6) are satisfied. Where variation of the spacing is necessary for any reason, the shear connectors should be spaced uniformly within two or more zones, changing at intermediate points which comply with clause 10.3.3.3(5).

In continuous beams, the shear connectors should be spaced more closely in negative moment regions, where this is necessary, to suit the curtailment of tension reinforcement. In cantilevers, the spacing of the shear connectors should be based on the curtailment of the tension reinforcement.

(2) Additional checks

Additional checks on the adequacy of the shear connection as recommended in clause 10.3.3.3(5) shall be made at intermediate points where any of the following apply.

- a) A heavy concentrated load occurs within a positive moment region.
- b) A sudden change of cross section occurs.
- c) The member is tapered (see clause 10.3.3.3(3)).
- d) The concrete flange is unusually large (see clause 10.3.3.3(4)).

In case a), a concentrated load should be considered as "heavy" if its free moment M_o exceeds 10% of the positive moment capacity of the composite section. The free moment M_o is the maximum moment in a simply supported beam of the same span due to the concentrated load acting alone.

(3) Tapered members

In members which reduce in depth towards their supports, additional checks as recommended in clause 10.3.3.3(5) shall be made at a series of intermediate points, selected such that the ratio of the greater to the lesser moment capacity for any pair of adjacent intermediate points does not exceed 2.5.

(4) Large concrete flanges

If the concrete flange is so large that the plastic moment capacity of the composite section exceeds 2.5 times the plastic moment capacity of the steel member alone, additional checks as recommended in clause 10.3.3.3(5) shall be made at intermediate points approximately mid-way between points of maximum positive moment and each adjacent support.

(5) Adequacy of shear connection at intermediate points

The adequacy of the shear connection shall be checked at all intermediate points where the spacing of shear connectors changes (see clause 10.3.3.3(1)) and at the intermediate points described in clause 10.3.3.3(2).

The total number of shear connectors between any such intermediate point and the adjacent support shall not be less than N_i determined from the following expressions:

For positive moments:

$$N_i = \frac{M - M_s}{M_c - M_s} N_p + N_n \quad \text{but } N_i \geq N_n \quad (10.28)$$

For negative moments:

$$N_i = \frac{M_c - M}{M_c - M_s} N_n \quad \text{but } N_i \leq N_n \quad (10.29)$$

where

M is the moment at the intermediate point;

M_c is the positive or negative moment capacity of the composite section, as appropriate;

M_s is the moment capacity of the steel member.

Alternatively, for positive moments, the adequacy of the shear connection shall be demonstrated by checking the plastic moment capacity at the intermediate point, assuming that the compressive force F_c in the concrete flange is equal to $(N_a - N_n) P_p$ where N_a is the actual number of shear connectors between the intermediate point and the adjacent support. In this check, the classification of the web (see clause 10.2) should also be based on the value of the ratio r determined using the above value of F_c .

(6) Curtailment of reinforcement

Where tension reinforcement is used in negative moment regions, every bar should extend beyond the point at which it is no longer required to assist in resisting the negative moment, by a distance not less than 12 times the bar size. In addition the lengths of the bars shall comply with the recommendations given in HKCC for anchorage of bars in a tension zone.

The longest bars shall extend beyond the zone containing the N_n shear connectors required to transfer the longitudinal force F_n , by a distance not less than the longitudinal spacing of the shear connectors. If necessary, the lengths of the bars should be increased to achieve this. Alternatively, the shear connectors should be spaced more closely in this region to avoid increasing the lengths of the bars.

10.3.4 Detailing of shear connectors

10.3.4.1 General

(1) Maximum spacing

The longitudinal spacing of shear connectors shall not normally exceed 600 mm or $4D_s$, whichever is less, where D_s is the overall depth of the slab.

Shear connectors may be arranged in groups, with a mean spacing as above and a maximum spacing of $8D_s$, provided that due account is taken of the resulting non-uniform flow of longitudinal shear and of the greater possibility of vertical separation between the concrete flange and the steel beam. Where the stability of either the steel beam or the concrete flange depends on the shear connectors, the maximum spacing should be limited accordingly, and appropriate resistance to uplift should be provided.

(2) Edge distance

The clear distance between a shear connector and the edge of the steel flange shall not be less than 20 mm (see Figure 10.7(a)).

(3) Minimum spacing

The minimum centre-to-centre spacing of stud shear connectors is $5d$ along the beam and $4d$ between adjacent studs, where d is the nominal shank diameter. Where rows of studs are staggered, the minimum transverse spacing of longitudinal lines of studs is $3d$.

(4) Maximum diameter

Unless located directly over the web, the nominal diameter of a stud shear connector should not exceed 2.5 times the thickness of the flange to which it is welded.

10.3.4.2 Other types of shear connectors

The dimensional details and the minimum spacing of other types of shear connector shall be within the ranges demonstrated as satisfactory by push out tests.

10.3.4.3 Haunches

Except where profiled steel sheets are used, the sides of a concrete haunch between the steel beam and the soffit of the slab should lie outside a line drawn at 45° from the outside edge of the shear connectors, and the concrete cover to the shear connectors should not be less than 50 mm (see Figure 10.7(b)).

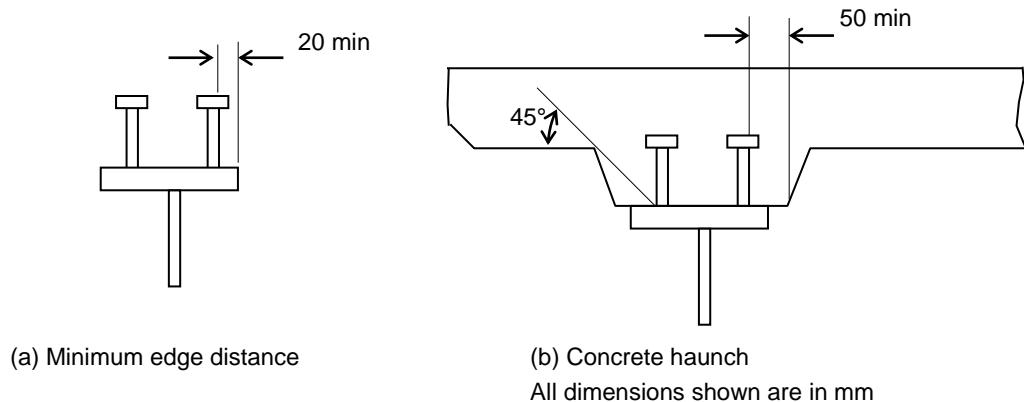

Figure 10.7 - Minimum dimensions

10.3.5 Transverse reinforcement

10.3.5.1 General

Transverse reinforcement refers to the reinforcement in the concrete flange running transverse to the span of the beam. Where profiled steel sheets are used they may also act as transverse reinforcement (see clause 10.3.5.4).

Sufficient transverse reinforcement should be used to enable the concrete flange to resist the longitudinal shear force transmitted by the shear connectors, both immediately adjacent to the shear connectors and elsewhere within its effective breadth.

10.3.5.2 Longitudinal shear in the slab

The total longitudinal shear force per unit length v to be resisted at any point in the span of the beam shall be determined from the spacing of the shear connectors by the following expression:

$$v = \frac{N P}{s} \quad (10.30)$$

where

- N is the number of shear connectors in a group;
- s is the longitudinal spacing centre-to-centre of groups of shear connectors;
- P is either P_p or P_n for shear connectors resisting positive or negative moments respectively (see clause 10.3.2.1).

For positive moments, the shear force on any particular surface of potential shear failure should be determined taking account of the proportion of the effective breadth of the concrete flange lying beyond the surface under consideration.

For negative moments, the shear force on any particular surface of potential shear failure should be determined taking account of the arrangement of the effective longitudinal reinforcement.

10.3.5.3 Resistance of concrete

For any surface of potential shear failure in the concrete flange, the longitudinal shear force per unit length shall not exceed the shear resistance v_r given by the following relationship:

$$v_r = 0.7 A_{sv} f_y + 0.03 \eta A_{cv} f_{cu} + v_p \quad (10.31a)$$

$$\leq 0.8 \eta A_{cv} \sqrt{f_{cu}} + v_p \quad (10.31b)$$

where

f_{cu} is the cube compressive strength of the concrete in N/mm^2 , but not more than $40 N/mm^2$ when concrete of higher strengths is used;

$\eta = 1.0$ for normal weight concrete;

A_{cv} is the mean cross-sectional area, per unit length of the beam, of the concrete shear surface under consideration;

A_{sv} is the cross-sectional area per unit length of the beam, of the combined top and bottom reinforcement crossing the shear surface (see clause Figure 10.8);

v_p is the contribution of the profiled steel sheets, if applicable (see clause 10.3.5.4).

Only reinforcement which is fully anchored should be included in A_{sv} . Where U-bars are used, they should be looped around the shear connectors.

The length of the shear surface $b-b$ shown in Figure 10.8 should be taken as

- i) $2h$ plus the head diameter for a single row of headed shear studs or staggered headed shear studs, or
- ii) $2h + s_t$ plus the head diameter for headed shear studs in pairs.

where

h is the height of the studs; and

s_t is the transverse spacing centre-to-centre of the studs.

Where a profiled steel sheet is used, it is not necessary to consider shear surfaces of type $b-b$, provided that the capacities of the studs are determined using the appropriate reduction factor k as recommended in clause 10.3.2.3.

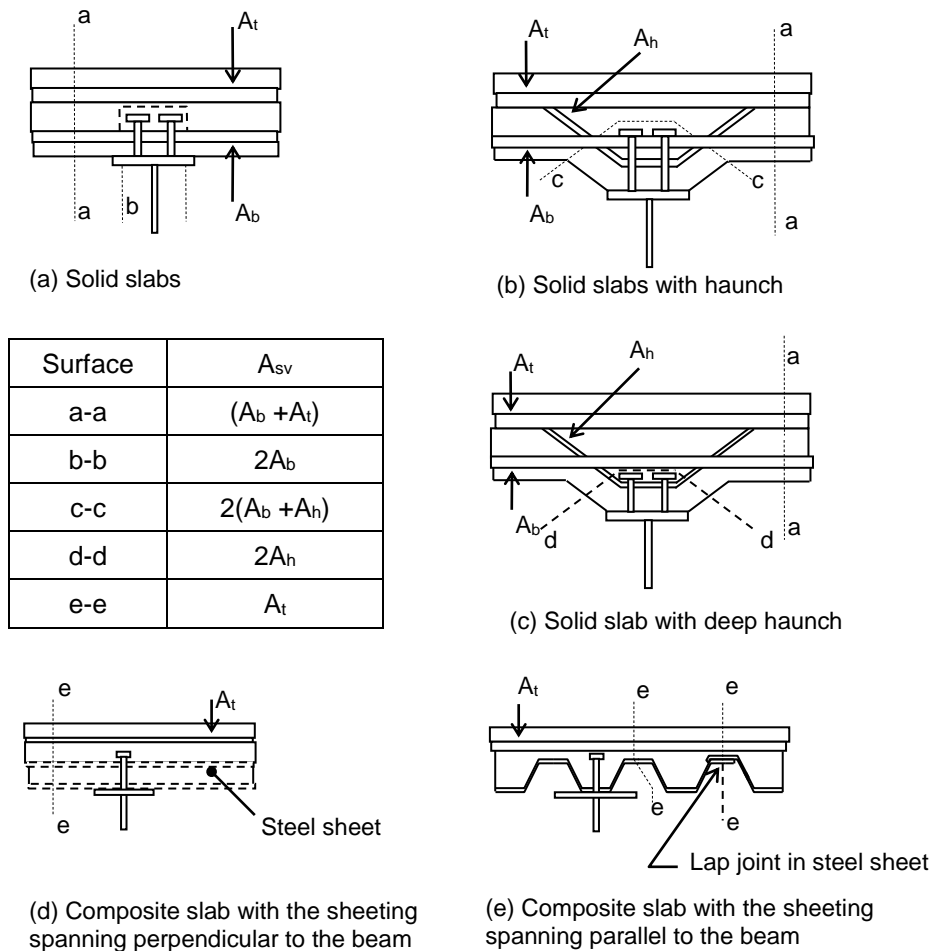

Figure 10.8 - Transverse shear surfaces

10.3.5.4 Contribution of profiled steel sheet

Profiled steel sheet is assumed to contribute to the transverse reinforcement provided that it is either continuous across the top flange of the steel beam or welded to the steel beam by headed shear studs.

The resistance of the concrete flange v_r given in clause 10.3.5.3 should be modified to allow for profiled steel sheets as follows:

- a) Where the profiled steel sheets are continuous across the top flange of the steel beam, the contribution of profiled steel sheet v_p which is defined as the resistance per unit length of the beam for each intersection of the shear surface by the profiled steel sheet, with ribs running perpendicular to the span of the beam is given by:

$$v_p = t_p \rho_y \quad (10.32)$$

where

t_p is the thickness of the profiled steel sheet;

ρ_y is the design strength of the profiled steel sheet; refer to clauses 3.8.1 and 11.2.2.

- b) Where the profiled steel sheet is discontinuous across the top flange of the steel beam, and headed shear studs are welded to the steel beam directly through the profiled steel sheets, the contribution of the profiled steel sheets v_p should be determined from the relationship:

$$v_p = (N/s)(n d t_p \rho_y) \leq t_p \rho_y \quad (10.33)$$

where

d is the diameter of the headed shear stud;

N and s are as given in clause 10.3.5.2;

n is taken as 4 unless a higher value is justified by tests.

In the case of a beam with separate spans of profiled steel sheets on each side, the studs should be staggered or arranged in pairs, so that each span of the profiled steel sheets is properly anchored.

- c) The area of concrete shear surface A_{cv} should be determined with full consideration on the orientation of the ribs as follows:

Where the ribs run perpendicular to the span of the beam, the concrete within the depth of the ribs should be included in the value of A_{cv} .

Where the ribs of the profiled steel sheets run parallel to the span of the beam, the potential shear failure surfaces at lap joints between the sheets should also be checked.

Where the ribs of the profiled steel sheets run at an angle θ to the span of the beam, the effective resistance is given by:

$$v_r = v_1 \sin^2 \theta + v_2 \cos^2 \theta \quad (10.34)$$

where

v_1 is the value of v_r for ribs perpendicular to the span;

v_2 is the value of v_r for ribs parallel to the span.

10.3.5.5 Longitudinal splitting

To prevent longitudinal splitting of the concrete flange caused by the shear connectors, the following recommendations should be applied in all composite beams where the distance from the edge of the concrete flange to the centreline of the nearest row of shear connectors is less than 300 mm.

- a) Transverse reinforcement shall be supplied by U-bars passing around the shear connectors. These U-bars shall be located at least 15 mm below the top of the shear connectors (see Figure 10.9).
- b) Where headed studs are used as shear connectors, the distance from the edge of the concrete flange to the centre of the nearest stud should not be less than $6d$, where d is the nominal diameter of the stud, and the U-bars should not be less than $0.5d$ in diameter and detailed as shown in Figure 10.9.

- c) The nominal bottom cover to the U-bars should be the minimum permitted by the design requirements for the concrete flange.

In addition, the recommendations given in clause 10.3.5.3 should be met.

Note: These conditions apply to edge beams and also to beams adjacent to large slab openings.

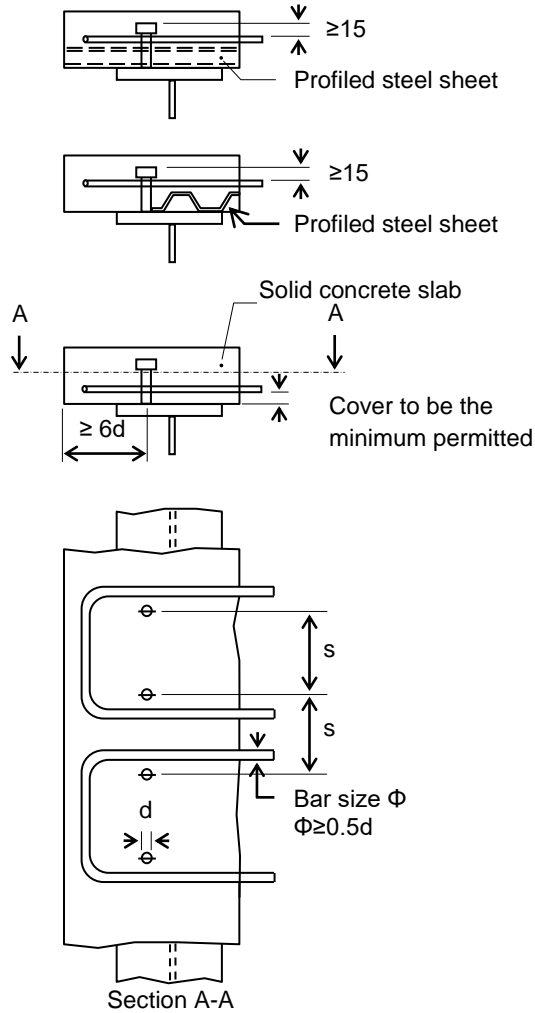

Figure 10.9 - Edge beam details

10.4 COMPOSITE SLABS WITH PROFILED STEEL SHEETS

10.4.1 General

- (1) This clause applies to the design composite slabs with profiled steel sheets in building construction where in-situ concrete is placed on profiled steel sheets, and they form a composite element after hardening of the concrete.
- (2) This clause applies to composite slabs with profiled steel sheets at yield strengths equal to or less than 550 N/mm² with a minimum bare metal thickness of 0.7 mm, and normal weight concrete of C25 to C45. It covers slabs spanning only in the direction of span of the profiled steel sheets.
- (3) At construction stage, profiled steel sheets shall be checked for
 - bending capacity;
 - shear capacity;
 - web crushing resistance;
 - combined bending and web crushing;
 - combined bending and shear; and
 - deflection.
- (4) At composite stage, composite slabs with profiled steel sheets shall be checked for
 - resistance to bending moment;
 - resistance to vertical shear;
 - resistance to shear-bond failure between profiled steel sheets and concrete slabs in the absence of any chemical bond at the interface; and
 - deflection.

It is essential to perform full-scale dynamics and static tests to demonstrate structural adequacy against shear-bond failure between the concrete and the profiled steel sheets. Refer to clause 16.4 for details of the test set-up, the testing procedures and the interpretation of the test results.

Moreover, full-scale structural fire tests are also required to demonstrate structural adequacy in load carrying capacity, insulation and integrity in fire limit state against specific fire resistant periods. Refer to clause 12.2 for fire resistance derived from standard fire tests. Alternatively, fire resistance derived from performance-based design method as described in clause 12.4 shall be adopted with proper justification.

- (5) For the design of composite steel beams with a composite slab as the concrete flange, reference should be made to clause 10.2. Diaphragm action produced by the capacity of the composite slab (or of the profiled steel sheets at the construction stage) to resist distortion in its own plane is not within the scope of the Code.

10.4.2 Form of construction

- (1) Composite slabs with profiled steel sheets act as composite elements to resist both dead and imposed loads during composite stage. In general, they are constructed without propping.
- (2) Composite action shall be obtained in one of the following ways:
 - a) by mechanical interlock;
 - b) by friction induced by the profile shape;
 - c) by a combination of end anchorages with either a) or b).Any bonding or adhesion of a chemical nature should be neglected in design.
- (3) Steel reinforcements should be provided to resist negative hogging moments and act as secondary and nominal reinforcements wherever necessary (see clause 10.4.6). However, steel reinforcements should not be used to resist positive sagging moments in combination with profiled steel sheets, unless the moment capacity has been determined by testing (see clause 10.4.3.2(2)).

- (4) Alternatively, the profiled steel sheets are designed to act only as permanent formwork which support the following types of loading during construction:
- self-weight of profiled steel sheets and wet concrete;
 - construction loads; and
 - storage loads.

In general, they are constructed without propping. Tensile reinforcement should be provided and the slab should be designed as a reinforced concrete slab as recommended in HKCC, without relying on composite action with the profiled sheets.

- (5) Where service ducts are formed in the slab, due allowance should be made for the resulting reduction in load carrying capacity.

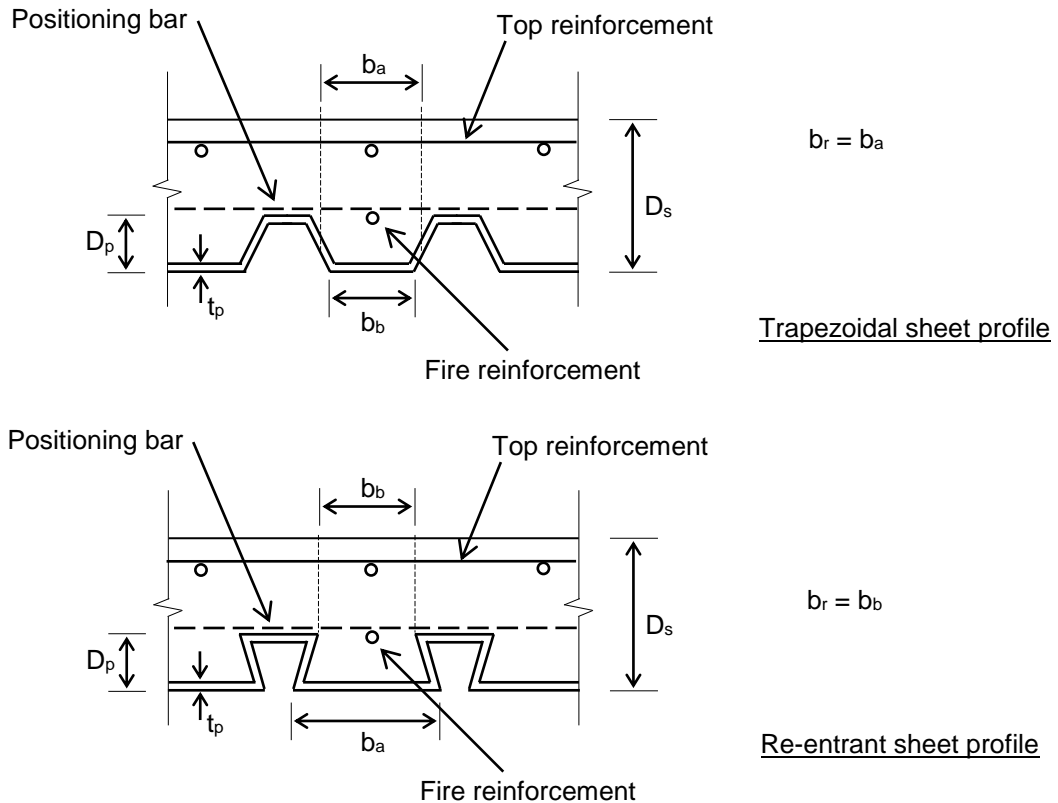

Figure 10.10 - Typical profiled steel sheets

10.4.3 Limit state design

10.4.3.1 General principles

Composite slabs should be designed by considering the limit states at which they would become unfit for their intended use.

It is essential to perform full-scale dynamics and static tests to demonstrate structural adequacy against shear-bond failure between the concrete and the profiled steel sheets. Refer to clause 16.4 for details of the test set-up, the testing procedures and the interpretation of the test results.

Moreover, full-scale structural fire tests are also required to demonstrate structural adequacy in load carrying capacity, insulation and integrity in fire limit state against specific fire resistant periods. Refer to clause 12.2 for fire resistance derived from standard fire tests. Alternatively, fire resistance derived from performance-based design method as described in clause 12.4 shall be adopted with proper justification.

Appropriate safety factors shall be applied for the ultimate, the fire and the serviceability limit states.

10.4.3.2 *Design methods*

(1) General

The following methods may be used for the design of composite slabs:

- a) composite design in which the concrete and the profiled steel sheets are assumed to act compositely to support loads (see clause 10.4.5);
- b) design by testing (see clause 10.4.3.2(2)); or
- c) design as a reinforced concrete slab as recommended in HKCC, neglecting any contribution from the profiled steel sheets.

In all cases, the profiled steel sheets shall be designed for use as permanent formwork during construction (see clause 10.4.4).

(2) Testing

a) Specific tests

Where testing is used as an alternative to calculation methods of design, the load carrying capacity of a composite slab may be determined directly from the results of specific tests as recommended in clause 16.4.2.

b) Parametric tests

In the calculation method for composite design given in clause 10.4.5, the shear-bond capacity shall be determined using the empirical parameters obtained from the results of parametric tests as recommended in clause 16.4.3.

10.4.3.3 *Ultimate limit states*

(1) Strength of materials

In the design of the profiled steel sheets before composite action with the concrete slab is developed, the design strength of the profiled steel sheets, p_y , should be taken as the yield strength of the steel materials divided by the appropriate material factor.

In the design of composite slabs, the design strength, p_y , of the profiled steel sheets should also be taken as the yield strength of the steel materials divided by the appropriate material factor.

Refer to clauses 3.8.1 and 11.2.2 for details.

The design strengths of the concrete, f_{cd} , and the steel reinforcement, f_{sd} , are given as follows:

$$f_{cd} = f_{cu} / \gamma_c \quad \gamma_c = 1.5 \quad (10.35a)$$

$$f_{sd} = f_y / \gamma_s \quad \gamma_s = 1.15 \quad (10.35b)$$

where

f_{cu} is the cube compressive strength of concrete;

f_y is the characteristic strength of steel reinforcement; and

γ_c, γ_s are the partial safety factors of concrete and steel reinforcement respectively.

All the properties of concrete and reinforcement shall follow the recommendations of HKCC.

(2) Nominal minimum slab thickness for fire resistance

In the absence of any other information, the nominal minimum slab thickness of concrete for composite slabs with both trapezoidal and re-entrant profiled steel sheets should comply with Tables 10.9 and 10.10.

10.4.3.4 *Serviceability limit states*

(1) Serviceability loads

Generally, the serviceability loads shall be taken as the unfactored values. When considering dead load plus imposed load plus wind load, only 80 % of the imposed load and the wind load need be considered. Construction loads shall not be included in the serviceability loads.

- (2) Deflections
Deflections under serviceability loads should not impair the strength or the use of the structure nor to cause any damage to finishes. The recommendations given in clause 10.4.4.4 should be followed for profiled steel sheets at the construction stage while those given in clause 10.4.5.4 should be followed for the deflection of composite slabs.

10.4.3.5 *Durability*

- (1) Corrosion protection of profiled steel sheets
The exposed surface at the underside of profiled steel sheets shall be adequately protected against relevant environmental conditions, including those arising during site storage and erection.
- (2) Concrete durability
For durability of concrete in composite slabs, the relevant recommendations in HKCC shall be followed.

Table 10.9 - Nominal minimum slab thickness of concrete – trapezoidal sheets

Fire resistance period (hours)	Nominal minimum insulation thickness of normal weight concrete above trapezoidal sheets excluding non-combustible screeds
0.5	60
1	70
1.5	80
2	95
3	115
4	130

Table 10.10 - Nominal minimum slab thickness of concrete – re-entrant sheets

Fire resistance period (hours)	Nominal minimum insulation thickness of normal weight concrete (equals to overall slab thickness)
0.5	90
1	90
1.5	110
2	125
3	150
4	170

10.4.4 Design of profiled steel sheets in construction stage

10.4.4.1 *General*

The design of profiled steel sheets before composite action is developed should follow the recommendations given in this sub-clause.

The cross sectional properties of profiled steel sheets should be evaluated according to the recommendations given in section 11. Embossments and indentations designed to provide composite action should be ignored when calculating the cross-sectional properties of profiled steel sheets.

Alternatively the load-carrying capacity of the profiled steel sheets shall be determined by testing.

10.4.4.2 Loads and span arrangement

- (1) For design purposes, the loads carried by the profiled steel sheets include:
- the self-weight of profiled steel sheets, wet concrete and reinforcements;
 - the construction loads (see clause 10.4.4.2(2));
 - the storage loads;
 - the effects of any temporary propping used at this stage, and
 - wind forces where necessary.

(2) The following loads during construction shall also be considered:

a) Basic construction loads

In general purpose working areas, the basic construction load of the profiled steel sheets should be taken as not less than 1.5 kN/m². For spans of less than 3 m, the basic construction load should be increased to not less than 4.5/L_p kN/m², where L_p is the effective span of the profiled steel sheets in metres. Construction loads with a partial load factor of 1.6 should be considered in addition to the self-weights of profiled steel sheets and wet concrete, both with a partial load factor of 1.4.

In order to determine the most critical combination of loaded spans in a continuous sheet, an end span should be taken as fully loaded while the adjacent span should be taken as either

- loaded with the self-weight of the wet concrete slab plus a construction load of one-third of the basic construction load, or
- unloaded apart from the self-weight of the profiled steel sheets whichever is the more critical for positive and negative moments in the sheet (see Figure 10.11).

It should be noted that the load factor for the self-weight of concrete may be reduced in construction sites where concreting sequences are carefully planned and properly performed.

b) Storage loads

In general, a minimum storage load of 3.0 kN/m² should be considered to be acting onto the profiled steel sheets together with the self-weight of profiled steel sheets. However, it is not necessary to consider storage loads together with construction load and self-weight of wet concrete.

c) Additional self-weight of concrete slab

The self-weight of the finished slab should be increased if necessary to allow for the additional concrete placed as a result of the “ponding” deflection of the profiled steel sheets (see clause 10.4.4.4(2)) for use in clause 10.2 and in the design of the supporting structure.

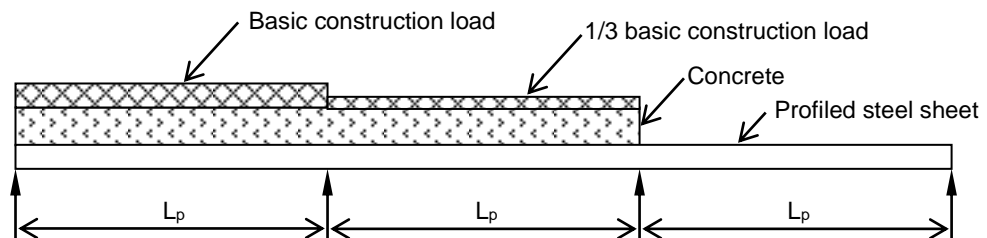

a) Arrangement for maximum negative moment

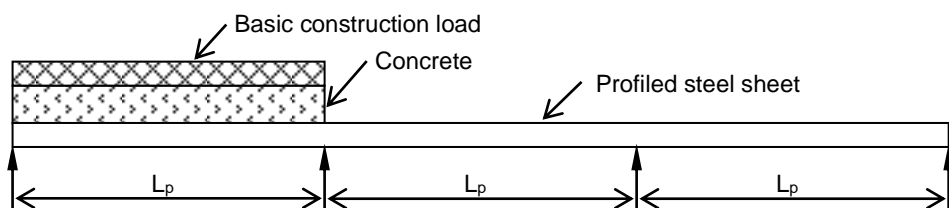

b) Arrangement for maximum positive moment

Figure 10.11 - Arrangement of construction loads

10.4.4.3 *Ultimate limit states*

In general, the load carrying capacities of profiled steel sheets shall be determined as recommended in section 11 by:

- a) calculation;
- b) testing; or
- c) a hybrid design method with calculation and testing.

The internal forces and moments of the profiled steel sheets are generally obtained from linear elastic analysis.

The section capacities shall be calculated with the following considerations:

- local buckling in flange elements under compression; and
- local buckling in web element under bending.

The following checks on the profiled steel sheets shall be carried out:

- bending capacity;
- shear capacity;
- web crushing resistance;
- combined bending and web crushing;
- combined bending and shear; and
- deflection.

10.4.4.4 *Serviceability limit states*

(1) The deflection of profiled steel sheets should be calculated as recommended in section 11 using the serviceability loads (see clause 10.4.3.4(1)) for the construction stage, comprising the self weight of the profiled steel sheets and the wet concrete only.

(2) The deflection, Δ , should not normally exceed the following:

- a) when $\Delta \leq D_s / 10$
 $\Delta \leq L_p / 180$ (but ≤ 20 mm) (10.36)
where L_p is the effective span of the profiled steel sheet.

- b) when $\Delta > D_s / 10$, the effect of ponding should be taken into account, i.e. the self weight of additional concrete due to the deflection of profiled steel sheets should be included in the deflection calculation. This may be evaluated by assuming that the nominal thickness of the concrete is increased by 0.7Δ over the entire span;
 $\Delta \leq L_p / 130$ (but ≤ 30 mm) (10.37)
Also refer to clause 5.2.

(3) In calculating the deflection of profiled steel sheets, the second moment of area of the profiled sheets at serviceability limit state, I_{ser} , may be taken as:

$$I_{ser} = \frac{1}{4} (2 I_{xg} + I_{xr,s} + I_{xr,h}) \geq 0.8 I_{xg} \quad (10.38)$$

- where I_{xg} = second moment of area of the gross section;
 $I_{xr,s}$ = second moment of area of the effective section under sagging moment due to serviceability load; and
 $I_{xr,h}$ = second moment of area of the effective section under hogging moment due to serviceability load.

(4) These limits should be increased only where it is shown that larger deflections will not impair the strength or efficiency of the slab. These limits should be reduced, if necessary, where soffit deflection is considered important, e.g. for service requirements or aesthetics.

10.4.5 **Design of composite slabs in composite stage**

10.4.5.1 *General*

- (1) Composite slabs shall be designed as either:
 - a) simply supported, with nominal reinforcement over intermediate supports; or
 - b) continuous, with full continuity reinforcement over intermediate supports in accordance with HKCC.

Where slabs or portions of slabs span onto supports in the transverse direction, this aspect of the design should be in accordance with HKCC.

- (2) Composite slabs are normally designed as simply supported, with nominal steel mesh reinforcement over supports.
- (3) For composite slabs designed as continuous slabs subjected to uniformly distributed imposed load, only the following arrangements of imposed load need to be considered.
 - a) alternate spans loaded; and
 - b) two adjacent spans loaded.

For dead load, the same value of the partial safety factor for loads γ_f should be applied on all spans.

If the effects of cracking of concrete are neglected in the analysis for ultimate limit states, the bending moments at internal supports may optionally be reduced by up to 30%, and corresponding increases made to the sagging bending moments in the adjacent spans.

Plastic analysis without any direct check on rotation capacity may be used for the ultimate limit state if reinforcing steel with sufficient ductility is used and the span is not greater than 3.0 m.

- (4) Analysis of internal forces and moments

The following methods of analysis may be used for ultimate limit states:

- linear elastic analysis with or without re-distribution;
- rigid plastic global analysis provided that it is shown that sections where plastic rotations are required have sufficient rotation capacity;
- elastic-plastic analysis, taking into account the non-linear material properties.

For serviceability limit states, linear elastic analysis methods shall be used.

- (5) Concentrated loads and reactions

Punching shear should also be checked where concentrated loads and reactions are applied to the slab (see clause 10.4.5.3(5)).

- (6) Effects of holes and ducts

Where holes or ducts interrupt the continuity of a composite slab, the region affected should be designed as reinforced concrete and reference should be made to HKCC.

10.4.5.2 *Design considerations*

- (1) The capacity of the composite slab shall be sufficient to resist the factored loads for the ultimate limit state, and all the critical sections indicated in Figure 10.12 shall be considered appropriately:
 - a) Flexural failure at section 1-1
This criterion is represented by the moment capacity of the composite slab, based on full shear connection at the interface between the concrete and the profiled steel sheets (see clause 10.4.5.3(1)).
 - b) Longitudinal slip at section 2-2
This criterion is represented by the shear-bond capacity along the interface between the concrete and the profiled steel sheets. In this case, the capacity of the composite slab is governed by the shear connection at section 2-2 (see clause 10.4.5.3(2)).
 - c) Vertical shear failure at section 3-3
This criterion is represented by the vertical shear capacity of the composite slab (see clause 10.4.5.3(4)). In general, vertical shear failure is rarely critical.
- (2) The composite slab should be designed assuming all the loading acts on the composite slab.

- (3) Where composite slabs are designed as continuous with full continuity reinforcement over internal supports in accordance with HKCC, the resistance to shear-bond failure contributed by the adjacent spans should be allowed for by basing the value of shear span L_v for use as described in clause 10.4.5.3(2)b on an equivalent simple span between points of contraflexure when checking the shear-bond capacity of an internal span. However, for end spans, the value of L_v should be based on the full end span length.
- (4) As an alternative to the design procedure given in clause 10.4.5.2(1), the relevant design criterion and capacity for a particular arrangement of profiled steel sheets and concrete slabs may be determined by testing.

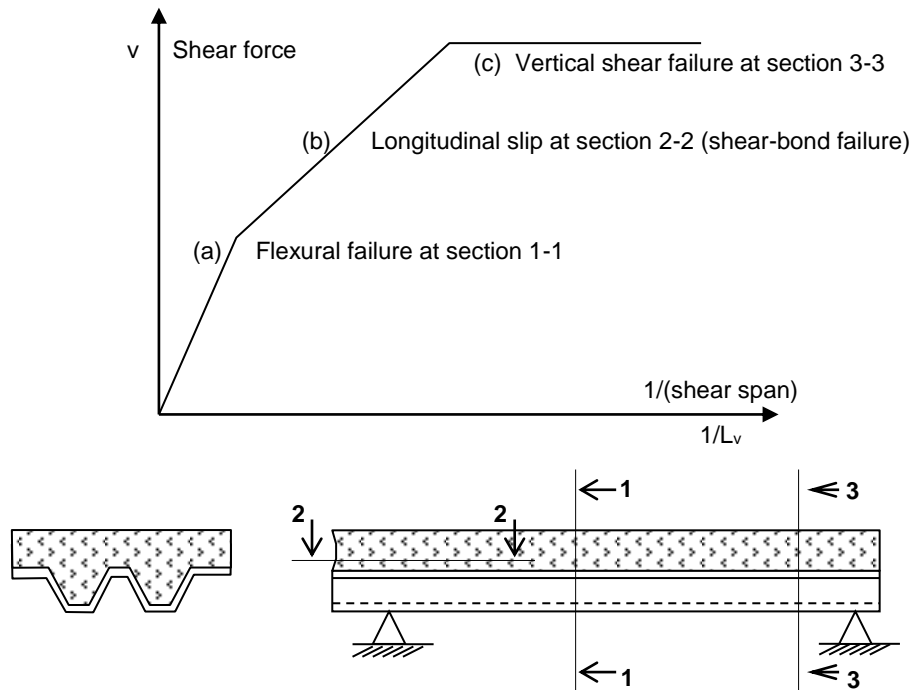

Figure 10.12 - Mode of failure of a composite slab

10.4.5.3 Ultimate limit states

(1) **Moment capacity**

The moment capacity at full shear connection shall be treated as an upper bound to the capacity of a composite slab. The moment capacity of a composite slab shall be calculated as for reinforced concrete, with the profiled steel sheets acting as tensile reinforcement.

The moment capacity in positive moment regions shall be determined assuming rectangular stress blocks for both concrete and profiled steel sheets. The design strengths shall be taken as $0.45f_{cu}$ for the concrete and p_y for the profiled steel sheeting (see Figure 10.13). The lever arm z should not exceed $0.95d_s$ and the depth of the stress block for the concrete should not exceed $0.45d_s$. Tension reinforcement in positive moment regions shall be neglected, unless the moment capacity is determined by testing.

The moment capacity in negative moment regions shall be determined as recommended in HKCC. In determining the negative moment capacity, the profiled steel sheets should be neglected.

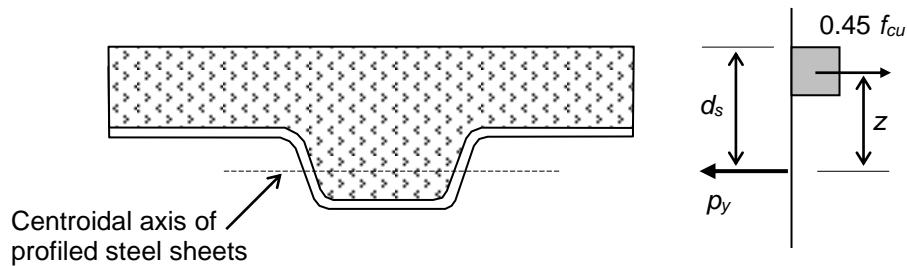

where

- d_s is the effective depth of slab to the centroid of the profiled steel sheets
- f_{cu} is the cube compressive strength of concrete
- ρ_y is the design strength of the profiled steel sheets
- z is the lever arm

Figure 10.13 - Stress blocks of moment capacity

(2) Longitudinal shear capacity for slabs without end anchorage

a) Shear-bond capacity V_s

When the load carrying capacity of a composite slab is governed by shear bond, it should be expressed in terms of the vertical shear capacity at the supports.

Generally the shear-bond capacity V_s (in N) shall be calculated using

$$V_s = \frac{B_s d_s}{1.25} \left[\frac{m_r A_p}{B_s L_v} + k_r \sqrt{f_{cu}} \right] \quad (10.39)$$

where

- A_p is the cross-sectional area of the profiled steel sheeting (in mm^2);
- B_s is the width of the composite slab (in mm);
- d_s is the effective depth of slab to the centroid of the profiled steel sheets (in mm);
- f_{cu} is the cube compressive strength of concrete (in N/mm^2);
- k_r is an empirical parameter (in $\sqrt{\text{N}/\text{mm}^2}$);
- L_v is the shear span of the composite slab (in mm), determined in accordance with clause 10.4.5.3(2)b; and
- m_r is an empirical parameter (in N/mm^2).

The factor of 1.25 is an additional partial safety factor γ_m , for the shear-bond capacity according to the sudden failure behaviour of the slab.

The empirical parameters m_r and k_r in this formula shall be obtained from parametric tests for the particular profiled sheet as recommended in section 16.4.3. In using this formula the value of A_p should not be taken as more than 10% greater than that of the profiled steel sheets used in the tests and the value of f_{cu} should not be taken as more than $1.1f_{cm}$ where f_{cm} is the value used in clause 16.4.3 to determine m_r and k_r .

When the value of k_r obtained from the tests is negative, the nominal strength grade of the concrete used in this formula should be not less than the nominal strength grade of the concrete used in the tests.

As an alternative to calculation of the shear-bond capacity, the load carrying capacity of the composite slab can be determined directly by means of specific tests according to clause 16.4.2.

Where it is necessary to use end anchors to increase the resistance to longitudinal shear above that provided by the shear-bond capacity V_s , reference should be made to clause 10.4.5.3(3).

b) Shear span L_v

The shear span L_v for a simply supported composite slab with a span of L_s shall be taken as:

- 0.25 L_s for a uniformly distributed load applied to the entire span;
- the distance between the applied load and the nearest support for two equal and symmetrically placed loads.

The shear span L_v for a continuous composite slab shall be taken as:

- 0.8 L for internal spans; or
- 0.9 L for external span

based on an equivalent iso-static span for the determination of the resistance.

For other loading arrangements, including partial distributed loads and asymmetrical point load systems, the shear span L_v should be determined on the basis of appropriate tests or by approximate calculations where the shear span may be taken as the maximum moment divided by the greater support reaction.

(3) Longitudinal shear capacity for slabs with end anchorage

End anchorage may be provided by headed shear studs welded to supporting steel beams by the technique of through-the-sheet welding with an end distance, measured to the centre line of the studs, of not less than 1.7 times the stud diameter, or by other suitable ductile shear connectors. Provided that not more than one shear connector is used in each rib of the profiled steel sheets, the shear capacity per unit width should be determined from

$$\bar{V}_a = \frac{NP_a(d_s - \frac{y_c}{2})}{L_v} \quad (10.40)$$

where

- N is the number of shear connectors attached to the end of each span of sheets, per unit length of supporting beam;
- d_s is the effective depth of the slab to the centroid of the profiled steel sheeting;
- y_c is the depth of concrete in compression at mid-span (for simplicity y_c may conservatively be taken as 20 mm);
- L_v is the shear span (for a uniformly loaded slab L_v is span/4); and
- P_a is the end anchorage capacity per shear connector.

For the conditions defined above, the end anchorage capacity should be obtained from

$$P_a = 4 d t_p p_y \quad (10.41)$$

where

- t_p is the thickness of profiled steel sheet,
- p_y is the design strength of profiled steel sheet.

Where end anchorage is used in conjunction with the shear bond between the concrete and the profiled steel sheets, the combined resistance to longitudinal shear should be limited as follows:

$$\bar{V}_c = \bar{V}_s + 0.5\bar{V}_a \quad \text{but} \quad \bar{V}_c \leq 1.5\bar{V}_s \quad (10.42)$$

where

- \bar{V}_c is the total longitudinal shear capacity per unit width of slab; and
- \bar{V}_s is the shear bond capacity per unit width.

(4) Vertical shear resistance

The vertical shear capacity V_v of a composite slab, over a width equal to the distance between centres of ribs, should be determined from the following:

- a) for open trough profile sheets: $V_v = b_a d_s v_c$ (10.43a)
- b) for re-entrant trough profile sheets: $V_v = b_b d_s v_c$ (10.43b)

where

- b_a is the mean width of a trough of an open profile (see Figure 10.10);
- b_b is the minimum width of a trough of a re-entrant profile (see Figure 10.10);

- d_s is the effective depth of the slab to the centroid of the sheet (see Figure 10.10); and
- v_c is the design concrete shear stress from HKCC taking A_s as A_p , d as d_s and b as B_s .

(5) Punching shear resistance

The punching shear capacity V_p of a composite slab at a concentrated load shall be determined from the method given in HKCC taking d as $D_s - D_p$ and the critical perimeter u as defined in Figure 10.14.

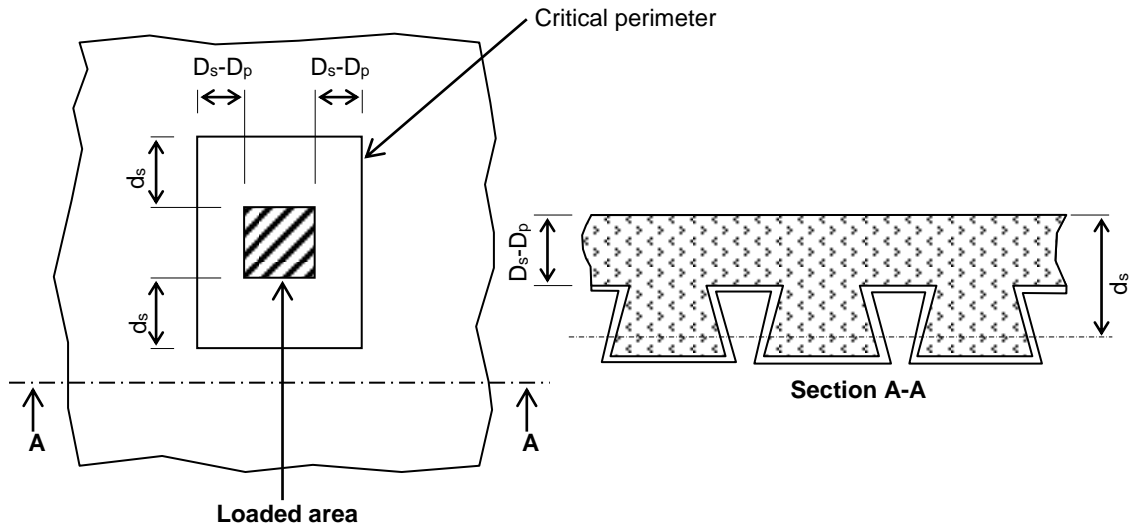

where

- D_p is the overall depth of profiled steel sheets;
- D_s is the overall depth of composite slab;
- d_s is the effective depth of the centroid of the profiled steel sheets,

Figure 10.14 - Critical perimeter for shear

10.4.5.4 Serviceability limit states

(1) Deflection

a) Limiting values

The deflection of composite slab shall be calculated using serviceability loads W_{ser} (see clause 10.4.3.4(1)), excluding the self-weight of the composite slab. The deflection of the profiled steel sheets due to its self weight and the self weight of wet concrete (calculated as in clause 10.4.4.4) shall not be included.

The deflection of the composite slab should not normally exceed the following:

- deflection due to the imposed load: $L_s/350$ or 20 mm, whichever is the lesser;
- deflection due to the total load less the deflection due to the self-weight of the slab plus, when props are used, the deflection due to prop removal: $L/250$.

These limits should be increased only where it is shown that larger deflections will not impair the strength or efficiency of the slab, lead to damage to the finishes or be unsightly. Also refer to clause 5.3.

b) Calculation

For uniformly distributed loading, the following approximate expressions may be used to calculate the deflection:

- for simply supported spans with nominal reinforcement over intermediate supports

$$\delta = \frac{5}{384} \frac{W_{ser} L_s^3}{EI_{CA}} \quad (10.44)$$

- for end spans of continuous slabs with full continuity reinforcement over intermediate supports of approximately equal span, i.e. within 15% of the maximum span

$$\delta = \frac{1}{100} \frac{W_{ser} L_s^3}{EI_{CA}} \quad (10.45)$$

- for two-span slabs with full continuity reinforcement over intermediate supports of approximately equal span, i.e. within 15% of the maximum span

$$\delta = \frac{1}{135} \frac{W_{ser} L_s^3}{EI_{CA}} \quad (10.46)$$

where

- E is the modulus of elasticity of the profiled steel sheets;
 I_{CA} is the second moment of area of the composite slab about its centroidal axis;
 L_s is the effective span of the composite slab; and
 W_{ser} is the serviceability load.

The factor 1/100 is derived by dividing 5/384 (for the simply supported case) by a factor of 1.3. The factor 1.3 is a ratio obtained from the basic span / effective depth ratios for both continuous and simply supported spans. The factor 1/135 is derived by comparing two-span and three-span cases.

The value of the second moment of area of the composite slab I_{CA} about its centroidal axis (in equivalent steel units) should be taken as the average of

- I_{CS} for the cracked section (i.e. the compression area of the concrete cross section combined with the profiled steel sheets on the basis of modular ratio) and
 I_{GS} for the gross section (i.e. the entire concrete cross section combined with the profiled steel sheets on the basis of modular ratio).

The modular ratio shall be determined as recommended in clause 10.2.

10.4.5.5 *Nominal reinforcement at intermediate supports*

Where continuous composite slabs are designed as simply supported, nominal steel fabric reinforcement should be provided over intermediate supports.

For propped construction, consideration should be given to increase the area of steel reinforcement over supports as appropriate, depending on the span and the crack widths that can be tolerated.

For mild exposure conditions in accordance with HKCC, the cross-sectional area of reinforcement in the longitudinal direction should be not less than 0.2% of the cross-sectional area of the concrete above the profiled steel sheets at the support. Refer to clause 10.2.7.3 for details.

10.4.5.6 *Transverse reinforcement*

The cross-sectional area of transverse reinforcement near the top of the slab should not be less than 0.1% of the cross-sectional area of the concrete above the profiled steel sheets.

The minimum cross-sectional area of transverse reinforcement should be increased to 0.2% of the cross-sectional area of the concrete above the profiled steel sheets in the vicinity of concentrated loads.

10.4.5.7 Shear connection

(1) Composite steel beams

Where composite slabs with profiled steel sheets are used to form the slabs of composite steel beams, the design of the shear connection should be in accordance with clause 10.2.

Where headed shear studs are assumed in design to also act as end anchors (see clause 10.4.5.3(3)) in simply supported composite slabs, in addition to connecting the slab to the steel beam, the following criteria should all be satisfied:

$$F_a \leq P_a \quad (10.47)$$

$$F_b \leq P_b \quad (10.48)$$

$$(F_a / P_a)^2 + (F_b / P_b)^2 \leq 1.1 \quad (10.49)$$

where

F_a is the end anchorage force per shear connector;

F_b is the beam longitudinal shear force per shear connector;

P_a is the end anchorage capacity per shear connector (see clause 10.4.5.3(3));

P_b is the capacity per shear connector for composite beam design in accordance with clause 10.2.

(2) Composite concrete beams

Where composite slabs with profiled steel sheets are used to form the slabs of composite concrete beams, the design of the shear connection should be in accordance with clause 10.3.

10.4.6 Detailing provisions

(1) Slab thickness

The overall depth of the composite slab D_s shall be sufficient to provide the required resistance to the effects of fire and as a minimum shall not be less than 90 mm as shown in Figure 10.15. In the absence of any other information, the thickness of concrete ($D_s - D_p$) above the main flat surface of the top of the ribs of the profiled steel sheets shall not be less than 50 mm subject to a concrete cover of not less than 15 mm above the top of any shear connectors.

(2) Arrangement of reinforcement

Top reinforcement, in the form of either bars or steel mesh fabric, should be provided in composite slabs as follows:

- a) nominal continuity reinforcement over intermediate supports, for simple spans;
- b) full continuity reinforcement over intermediate supports, for continuous spans and for cantilevers;
- c) secondary transverse reinforcement to resist shrinkage and temperature stresses;
- d) distribution steel, where concentrated loads are applied and around openings.

In general, bottom reinforcement is not needed.

Where necessary, top and bottom reinforcements should also be provided to increase the fire resistance of the composite slab.

(3) Size of concrete aggregate

As shown in Figure 10.15, the nominal maximum size of the concrete aggregate h_{agg} depends on the smallest dimension in the structural element within which concrete is poured and should not be larger than the least of:

- a) $0.4 (D_s - D_p)$ (see Figure 10.15);
- b) $b_b / 3$ (see Figure 10.15); and
- c) 20 mm.

- (4) Cover to reinforcement
Steel reinforcement in a slab in the form of bars or steel mesh fabric shall be positioned as follows:
- Longitudinal reinforcement near the top of the slab should have at least 20 mm nominal cover.
 - Longitudinal reinforcement in the bottom of the slab, if needed, should be so positioned that sufficient space, not less than the nominal maximum size of the aggregate, is left between the reinforcement and the sheets to ensure proper compaction of the concrete.
 - Secondary transverse reinforcement for controlling shrinkage should be placed in the top of the slab with at least 20 mm nominal cover.
 - Fire resistance reinforcement intended to provide positive moment capacity should be placed near the bottom of the slab with not less than 20 mm between the reinforcement and the profiled steel sheets.
 - Transverse bars (which are not reinforcement) for positioning of longitudinal reinforcement or fire resistance reinforcement, if needed, may be placed directly on the top of the ribs of the sheets.
 - Fire resistance reinforcement for negative moment capacity should be placed near the top of the slab with at least 20 mm nominal cover.
 - Distribution steel in areas of concentrated loads and around openings should be placed directly on the top of the ribs of the sheets, or not more than a nominal 20 mm above it.

The curtailment and lapping of reinforcement shall conform to HKCC. Where a single layer of reinforcement is used to fulfill more than one of the above purposes, it should satisfy all the relevant recommendations.

Note: Where a composite slab forms the concrete flange of a composite beam, clause 10.3.5 gives recommendations for transverse reinforcement of the beam, running perpendicular to the span of the beam. Such reinforcement can be either longitudinal or transverse relative to the slab.

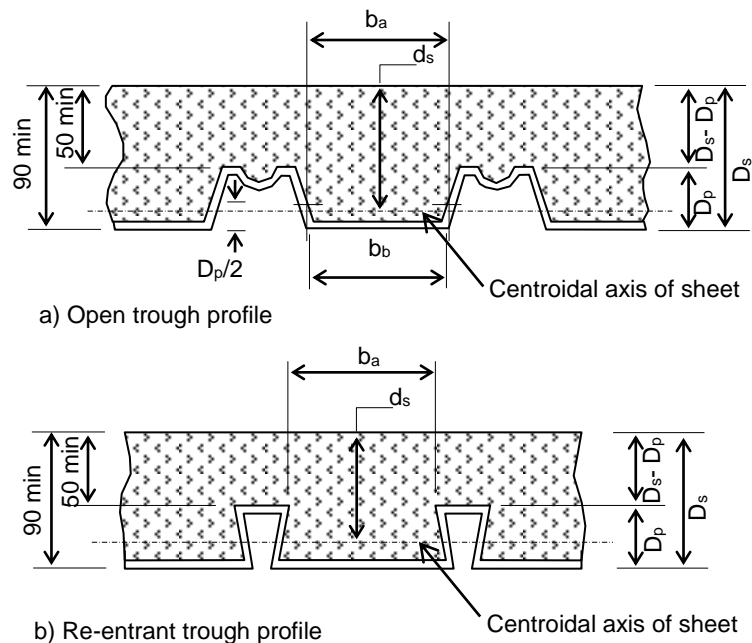

All dimensions are in millimeters.

where

- b_a is the mean width of the trough;
- b_b is the minimum width of the trough;
- D_p is the overall depth of the profiled steel sheets;
- D_s is the overall depth of the composite slab;
- d_s is the effective depth of slab to the centroid of the profiled steel sheets

Figure 10.15 - Sheet and slab dimensions

10.4.7 Constructional details

(1) Minimum bearing requirements

As shown in Figure 10.16, composite slabs bearing on steel or concrete should normally have an end bearing of not less than 50 mm. For composite slabs bearing on other materials, the end bearing should normally be not less than 70 mm.

For continuous slabs the minimum bearing at intermediate supports should normally be 75 mm on steel or concrete and 100 mm on other materials as shown in Figure 10.16.

Where smaller bearing lengths are adopted, account should be taken of all relevant factors such as tolerances, loading, span, height of support and provision of continuity reinforcement. In such cases, precautions should also be taken to ensure that fixings (clause 10.4.7(2)) can still be achieved without damage to the bearings, and that collapse cannot occur as a result of accidental displacement during erection.

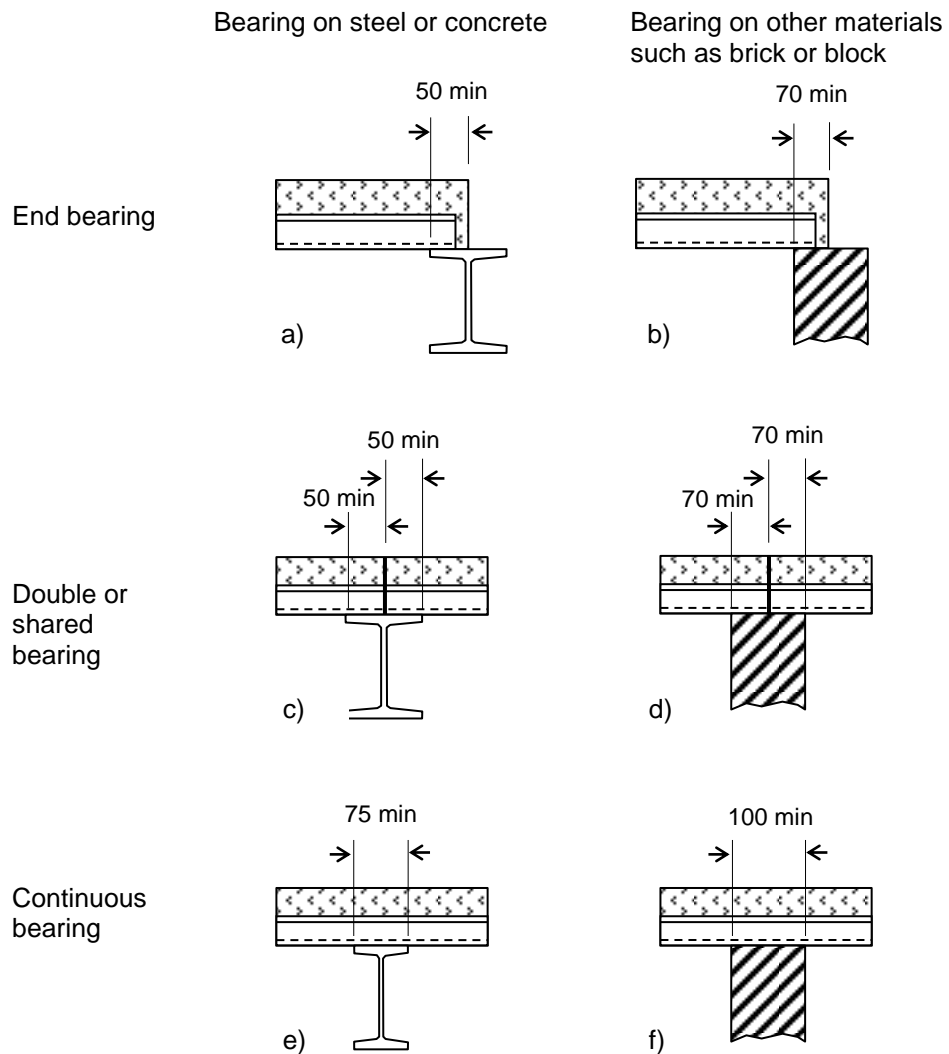

Figure 10.16 - Bearing requirements

(2) Sheet fixings

The design should incorporate provision for the profiled steel sheets to be fixed:

- a) to keep them in position during construction so as to provide a subsequent safe working platform;
- b) to ensure connection between the sheets and supporting beams;
- c) to ensure connection between adjacent sheets where necessary;
- d) to transmit horizontal forces where necessary; and
- e) to prevent uplift forces displacing the sheets.

For fixing sheets to steelwork, the following types of fixing are available:

- shot fired fixings;
- self-tapping screws;
- welding;
- stud shear connectors welded through the sheeting; or
- bolting.

Due consideration should be given to any adverse effect on the supporting members. Site welding of very thin sheets should not be relied on to transfer end anchorage forces, unless the practicality and quality of the welded connections can be demonstrated by tests.

When sheets are to be attached to brickwork, blockwork, concrete or other materials where there is a danger of splitting, fixing should be by drilling and plugging or by the use of suitable proprietary fixings.

The number of fasteners should not be less than two per sheet at the ends of sheets nor less than one per sheet where the sheets are continuous. The spacing of fasteners should not be larger than 500 mm at the ends of sheets nor greater than 1000 mm where the sheets are continuous. At side laps the sheets should be fastened to each other, as necessary, to control differential deflection, except where the sides of the sheets are supported or are sufficiently interlocking.

The design of sheet fixings should be in accordance with section 11.

10.5 COMPOSITE COLUMNS

10.5.1 General

- (1) This clause applies for the design of composite columns and composite compression members with fully encased H sections, partially encased H sections and infilled rectangular and circular hollow sections, see Figure 10.17.

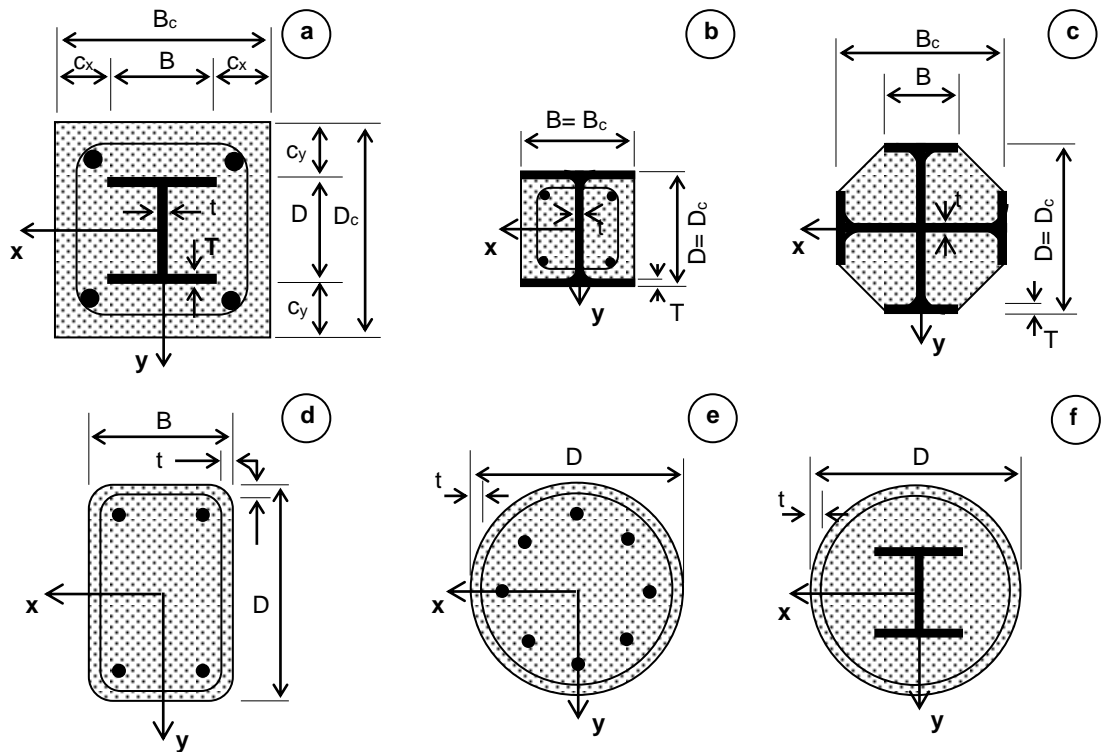

Figure 10.17 - Typical cross-sections of doubly symmetrical composite columns

- (2) Composite columns or compression members of any cross-section shall be checked for:
- resistance of the member in accordance with clause 10.5.2 or 10.5.3,
 - resistance to local buckling in accordance with clause 10.5.3.1(4),
 - introduction of loads in accordance with clause 10.5.4.2 and
 - resistance to shear between steel and concrete elements in accordance with clause 10.5.4.
- (3) This clause applies to columns and compression members using steel sections with yield strengths between 235 and 460 N/mm², and normal weight concrete of strength classes C25 to C60.
- (4) This clause applies to isolated columns and composite compression members in framed structures where the other structural members are either composite or steel members.
- (5) Two methods of design are given:
- a general method in clause 10.5.2 whose scope includes members with non-symmetrical or non-uniform cross-sections over the column length and
 - a simplified method in clause 10.5.3 for members of doubly symmetrical and uniform cross section over the member length.
- (6) Refer to clause 3.1.2 for the design strength of the structural steel section, p_y . The design strengths of the concrete, f_{cd} , and the steel reinforcement, f_{sd} , are given as follows:

$$f_{cd} = f_{cu} / \gamma_c \quad \gamma_c = 1.5 \quad (10.50a)$$

$$f_{sd} = f_y / \gamma_s \quad \gamma_s = 1.15 \quad (10.50b)$$

where

f_{cu} is the cube compressive strength of concrete;

f_y is the characteristic strength of steel reinforcement; and

γ_c, γ_s are the partial safety factors of concrete and steel reinforcement, respectively.

10.5.2 General method of design

- (1) Design for structural strength and stability shall take into the account of concrete crushing, and yielding of structural steel sections and steel reinforcement.

The design shall also ensure that instability does not occur for the most unfavourable combination of actions at the ultimate limit state and that the resistance of individual cross-sections subjected to bending, longitudinal force and shear is not exceeded.

Furthermore, second-order effects shall be incorporated including local buckling, residual stresses, geometrical imperfections, and long-term effects on concrete such as creeping and shrinkage of concrete.

Second-order effects shall also be considered in any direction in which failure might occur, if they affect the structural stability significantly. For simplification, instead of the effect of residual stresses and geometrical imperfections, equivalent initial bow imperfections (member imperfections) may be used in accordance with clause 10.5.3.3(3).

- (2) Internal forces shall be determined by elastic-plastic analysis.

Plane sections may be assumed to remain plane after bending.

The influence of local buckling of the structural steel section on the resistance shall be considered in design.

- (3) The following stress-strain relationships shall be used in the non-linear analysis:
- for concrete in compression as given in HKCC;
 - for reinforcing steel as given in HKCC;
 - for structural steel as given in section 3.

The tensile strength of concrete shall be neglected. The influence of tension stiffening of concrete between cracks on the flexural stiffness may be taken into account.

- (4) The steel contribution ratio δ shall fulfill the following condition:

$$0.2 \leq \delta \leq 0.9 \quad (10.51)$$

where

δ is defined in clause 10.5.3.2(2).

- (5) Shrinkage and creep effects shall be considered if they are likely to reduce the structural stability significantly.

For simplification, creep and shrinkage effects may be ignored if the increase in the first-order bending moments due to creep deformations and longitudinal force resulting from permanent loads is not greater than 10%.

- (6) For composite compression members subjected to bending moments and normal forces resulting from independent actions, the partial safety factor γ_f for those internal forces that lead to an increase of resistance should be reduced to 80%.

10.5.3 Simplified method of design

10.5.3.1 General and scope

- (1) The scope of this simplified method is limited to members of doubly symmetrical and uniform cross-section over the member length with rolled, cold-formed or welded steel sections.

However, this method is not applicable if the structural steel component consists of two or more unconnected sections. All internal forces and moments for member design against structural adequacy should be evaluated with second-order analysis.

- (2) The steel contribution ratio δ shall fulfill the following condition:
- $$0.2 \leq \delta \leq 0.9 \quad (10.52)$$

where

δ is defined in clause 10.5.3.2(2).

- (3) The relative slenderness $\bar{\lambda}$ defined in clause 10.5.3.3 shall fulfill the following condition:

$$\bar{\lambda} \leq 2.0 \quad (10.53)$$

- (4) The effect of local plate buckling in the elements of a steel section may be neglected for the steel section is fully encased in accordance with clause 10.5.5.1(2), and also for other types of cross-section provided the maximum values of Table 10.11 are not exceeded. Hence, the entire composite cross-sections are effective.

Table 10.11 - Maximum values on geometric ratios

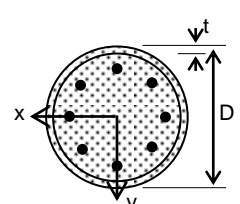
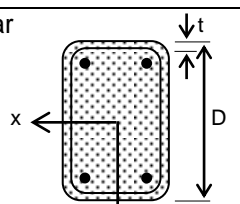
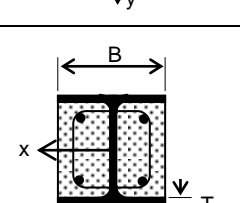
Cross-section	Max (D/t) and max (B/T)
Infilled circular hollow sections 	$\text{Max} \left(\frac{D}{t} \right) = 77 \times \left(\frac{275}{p_y} \right)$
Infilled rectangular hollow sections 	$\text{Max} \left(\frac{D}{t} \right) = 48 \times \left(\sqrt{\frac{275}{p_y}} \right)$
Partially encased H-sections 	$\text{Max} \left(\frac{B}{T} \right) = 41 \times \left(\sqrt{\frac{275}{p_y}} \right)$

Note: p_y in N/mm².

- (5) The longitudinal reinforcement that may be used in calculation shall not exceed 6% of the concrete area.

- (6) For a fully encased steel section, see Figure 10.17a, limits to the maximum thickness of concrete cover that may be used in calculation are:

$$\max c_y = 0.3 D \quad \max c_x = 0.4 B \quad (10.54)$$

(7) The depth to width ratio D_c / B_c of fully encased composite cross-sections as shown in Figure 10.17a shall be within the limits $0.2 < D_c / B_c < 5.0$.

(8) For the determination of the internal forces, the design value of effective flexural stiffness $(EI)_{e,1}$ shall be determined from the following expression:

$$(EI)_{e,1} = 0.9 (EI + E_s I_s + 0.5 E_{cm} I_c) \quad (10.55)$$

Long-term effects should be taken into account in accordance with clause 10.5.3.3(6).

(9) Second-order effects need not to be considered where the elastic critical buckling load is determined with the flexural stiffness $(EI)_{e,1}$ in accordance with clause 10.5.3.1(8).

(10) Within the column length, second-order effects may be allowed for by increasing the greatest first-order design bending moment M by a factor k given by:

$$k = \frac{\beta}{1 - P / P_{cp,cr}} \quad (10.56)$$

where

$P_{cp,cr}$ is the critical buckling load for the relevant axis and corresponding to the effective flexural stiffness given in clause 10.5.3.1(8), with the effective length taken as the column length;

$$= \frac{\pi^2 (EI)_{e,1}}{L_E^2} \quad (10.57)$$

β is an equivalent moment factor given in Table 10.12.

Table 10.12 - Factors β for the determination of moments to second order theory

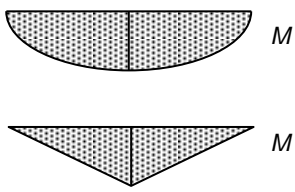
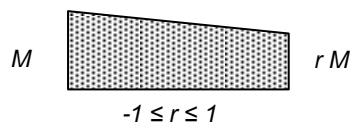
Moment distribution	Moment factors β	Comment
	<p>First-order bending moments from member imperfection or lateral load:</p> $\beta = 1.0$	<p>M is the maximum bending moment within the column length ignoring second-order effects</p>
	<p>End moments:</p> $\beta = 0.66 + 0.44r$ <p>but $\beta \geq 0.44$</p>	<p>M and rM are the end moments from first-order or second-order global analysis</p>

(11) The influence of geometrical and structural imperfections may be taken into account by equivalent geometrical imperfections. Equivalent member imperfections for composite columns are given in Table 10.13, where L is the column length.

10.5.3.2 Compression capacity

- (1) The compression capacity P_{cp} of a composite cross-section shall be calculated by adding the compression capacities of its components:

For fully encased and partially encased H sections:

$$P_{cp} = A p_y + 0.45 A_c f_{cu} + A_s f_{sd} \quad (10.58a)$$

For infilled rectangular hollow sections:

$$P_{cp} = A p_y + 0.53 A_c f_{cu} + A_s f_{sd} \quad (10.58b)$$

where

A , A_c , A_s are the areas of the steel section, the concrete and the reinforcements respectively.

- (2) The steel contribution ratio δ is defined as:

$$\delta = \frac{A p_y}{P_{cp}} \quad (10.59)$$

where

P_{cp} is the compression capacity of the composite cross-section defined in clause 10.5.3.2(1).

- (3) For infilled circular hollow sections, account may be taken of increase in strength of concrete caused by confinement provided that the relative slenderness $\bar{\lambda}$ defined in clause 10.5.3.3(3) does not exceed 0.5 and $\frac{e}{d} < 0.1$, where e is the eccentricity of loading given by M/P and d is the external diameter of the column. The compression capacity for infilled circular hollow sections shall be calculated as follows:

$$P_{cp} = \eta_a A p_y + 0.53 A_c f_{cu} \left[1 + \eta_c \frac{t}{d} \frac{p_y}{0.8 f_{cu}} \right] + A_s f_{sd} \quad (10.60)$$

where

t is the wall thickness of the steel tube.

For members in combined compression and bending with $0 < \frac{e}{d} < 0.1$, the values η_a and η_c are given as follows:

$$\eta_a = \eta_{a0} + (1 - \eta_{a0}) \left(10 \frac{e}{d} \right) \quad (\text{but } < 1.0) \quad (10.61)$$

$$\eta_c = \eta_{c0} \left(1 - 10 \frac{e}{d} \right) \quad (\text{but } < 1.0) \quad (10.62)$$

where

$$\eta_{a0} = 0.25 (3 + 2 \bar{\lambda}) \quad (\text{but } < 1.0) \quad (10.63)$$

$$\eta_{c0} = 4.9 - 18.5 \bar{\lambda} + 17 \bar{\lambda}^2 \quad (\text{but } \geq 0) \quad (10.64)$$

10.5.3.3 Column buckling

- (1) Members may be verified using second order analysis according to clause 10.5.3.5 taking into account of member imperfections.
- (2) For simplification for members susceptible to axial buckling using first order analysis, the design value of the compression force P shall satisfy:

$$\frac{P}{\chi P_{cp}} \leq 1.0 \quad (10.65)$$

where

P_{cp} is the compression capacity of the composite section according to clause 10.5.3.2(1);

χ is the reduction factor for the column buckling given in clause 10.5.3.3(3) in term of the relevant relative slenderness $\bar{\lambda}$ given in clause 10.5.3.3(4).

(3) The reduction factor χ for column buckling is given by:

$$\chi = \frac{1}{\phi + \sqrt{\phi^2 - \bar{\lambda}^2}} \quad \text{but} \quad \chi \leq 1.0 \quad (10.66)$$

where

$$\phi = \frac{1}{2} \left[1 + \alpha (\bar{\lambda} - 0.2) + \bar{\lambda}^2 \right] \quad (10.67)$$

α is the imperfection factor which allows for different levels of imperfections in the columns

= 0.21 for buckling curve a

= 0.34 for buckling curve b

= 0.49 for buckling curve c

The relevant buckling curves for various cross-sections of composite columns are given in Table 10.13, and the buckling strength reduction factors of composite column are given in Table 10.14.

(4) The relative slenderness $\bar{\lambda}$ for the plane of bending being considered is given by:

$$\bar{\lambda} = \sqrt{\frac{P_{cp,k}}{P_{cp,cr}}} \quad (10.68)$$

where

$P_{cp,k}$ is the characteristic value of the compression capacity which is given by:

$$= A p_y + 0.68 A_c f_{cu} + A_s f_y \quad \text{for fully encased and partially encased H sections} \quad (10.69a)$$

$$= A p_y + 0.8 A_c f_{cu} + A_s f_y \quad \text{for infilled rectangular hollow sections} \quad (10.69b)$$

$$= \eta_a A p_y + 0.8 A_c f_{cu} \left[1 + \eta_c \frac{t}{d} \frac{p_y}{0.8 f_{cu}} \right] + A_s f_y \quad \text{for infilled circular hollow sections} \quad (10.69c)$$

$P_{cp,cr}$ is the elastic critical buckling load for the relevant buckling mode, calculated with the effective flexural stiffness $(EI)_{e,2}$ determined in accordance with clauses 10.5.3.3(5) and 10.5.3.3(6).

$$= \frac{\pi^2 (EI)_{e,2}}{L_E^2} \quad (10.70)$$

(5) For the determination of the relative slenderness $\bar{\lambda}$ and the elastic critical buckling load N_{cr} , the characteristic value of the effective flexural stiffness $(EI)_{e,2}$ of a composite column should be calculated from:

$$(EI)_{e,2} = EI + K_e E_{cm} I_c + E_s I_s \quad (10.71)$$

where

K_e is a correction factor that shall be taken as 0.6.

I , I_c , and I_s are the second moments of area of the structural steel section, the un-cracked concrete section and the reinforcement respectively for the bending plane being considered.

(6) Account should be taken to the influence of long-term effects on the effective elastic flexural stiffness. The modulus of elasticity of concrete E_{cm} should be reduced to the value E_c in accordance with the following expression:

$$E_c = E_{cm} \frac{1}{1 + (P_G / P) \varphi_t} \quad (10.72)$$

where

ϕ_t is the creep coefficient;

P is the total design normal force;

P_G is the part of this normal force that is permanent.

For the determination of the creep coefficient in accordance with HKCC, a relative humidity of 100% may be assumed for concrete infilled hollow sections.

Table 10.13 - Buckling curves and member imperfections for composite columns

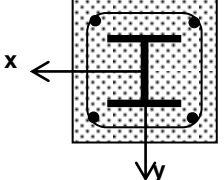
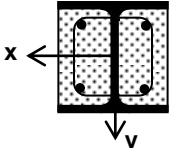
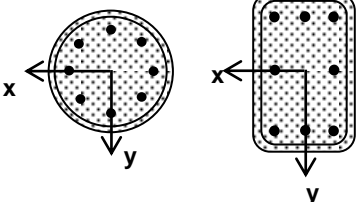
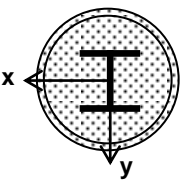
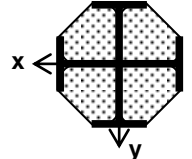
Cross-section	Limits	Axis of buckling	Buckling curve	Member imperfection
Fully encased H section 		x-x	b	L/200
		y-y	c	L/150
Partially encased H section 		x-x	b	L/200
		y-y	c	L/150
Infilled circular and rectangular hollow sections 	$\rho_s \leq 3\%$	any	a	L/300
	$3\% < \rho_s \leq 6\%$	any	b	L/200
Infilled circular hollow section with additional H section 		x-x	b	L/200
		y-y	b	L/200
Partially encased H section with crossed H section 		any	b	L/200

NOTE: ρ_s is the reinforcement ratio A_s/A_c .

Table 10.14 - Buckling strength reduction factors of composite columns

$\bar{\lambda}$	Buckling curve		
	a	b	c
0.00	1.000	1.000	1.000
0.05	1.000	1.000	1.000
0.10	1.000	1.000	1.000
0.15	1.000	1.000	1.000
0.20	1.000	1.000	1.000
0.25	0.989	0.982	0.975
0.30	0.977	0.964	0.949
0.35	0.966	0.945	0.923
0.40	0.953	0.926	0.897
0.45	0.939	0.906	0.871
0.50	0.924	0.884	0.843
0.55	0.908	0.861	0.815
0.60	0.890	0.837	0.785
0.65	0.870	0.811	0.755
0.70	0.848	0.784	0.725
0.75	0.823	0.755	0.694
0.80	0.796	0.724	0.662
0.85	0.766	0.693	0.631
0.90	0.734	0.661	0.600
0.95	0.700	0.629	0.569
1.00	0.666	0.597	0.540
1.05	0.631	0.566	0.511
1.10	0.596	0.535	0.484
1.15	0.562	0.506	0.458
1.20	0.530	0.478	0.434
1.25	0.499	0.452	0.411
1.30	0.470	0.427	0.389
1.35	0.443	0.404	0.368
1.40	0.418	0.382	0.349
1.45	0.394	0.361	0.331
1.50	0.372	0.342	0.315

$\bar{\lambda}$	Buckling curve		
	a	b	c
1.55	0.352	0.324	0.299
1.60	0.333	0.308	0.284
1.65	0.316	0.292	0.271
1.70	0.299	0.278	0.258
1.75	0.284	0.265	0.246
1.80	0.270	0.252	0.235
1.85	0.257	0.240	0.224
1.90	0.245	0.229	0.214
1.95	0.234	0.219	0.205
2.00	0.223	0.209	0.196
2.05	0.213	0.200	0.188
2.10	0.204	0.192	0.180
2.15	0.195	0.184	0.173
2.20	0.187	0.176	0.166
2.25	0.179	0.169	0.160
2.30	0.172	0.163	0.154
2.35	0.165	0.157	0.148
2.40	0.159	0.151	0.143
2.45	0.152	0.145	0.137
2.50	0.147	0.140	0.132
2.55	0.141	0.135	0.128
2.60	0.136	0.130	0.123
2.65	0.131	0.125	0.119
2.70	0.127	0.121	0.115
2.75	0.122	0.117	0.111
2.80	0.118	0.113	0.108
2.85	0.114	0.109	0.104
2.90	0.111	0.106	0.101
2.95	0.107	0.103	0.098
3.00	0.104	0.099	0.095

10.5.3.4 Moment capacity

The moment capacity of a doubly symmetric composite cross-section may be evaluated as follows:

$$M_{cp} = p_y (S_p - S_{pn}) + 0.5 \alpha_c f_{cu} (S_{pc} - S_{pcn}) + f_{sd} (S_{ps} - S_{psn}) \quad (10.73)$$

where

- α_c = 0.53 for all infill hollow sections
= 0.45 for fully or partially encased H sections
- S_p, S_{ps}, S_{pc} are the plastic section moduli for the steel section, the reinforcement and the concrete of the composite cross-section respectively (for the calculation of S_{pc} , the concrete is assumed to be uncracked).
- S_{pn}, S_{psn}, S_{pcn} are the plastic section moduli of the corresponding components within the region of $2 d_n$ from the middle line of the composite cross-section.
- d_n is the depth of the neutral axis from the middle line of the cross-section.

10.5.3.5 Combined compression and uni-axial bending

- (1) For combined compression and bending based on first order analysis, both local capacity and overall stability shall be checked.

As an alternative, for composite columns subjected to combined compression and bending based on second order analysis, local capacity and overall stability of composite columns shall be checked at the same time provided that all the moments are properly evaluated to include second order moments.

- (2) Local capacity check

The section capacity of a composite cross-section under combined compression and bending based on first order analysis shall be evaluated through the use of an interaction curve as shown in Figure 10.18.

Figure 10.18a shows the interaction curve of an infilled rectangular hollow section (with points A to E) while Figure 10.18b shows the same of a fully encased H section (with points A to D).

It is important to note that

- Point A marks the compression capacity of the composite cross-section:
 $P^A = P_{cp} \quad (10.74a)$
 $M^A = 0 \quad (10.74b)$
- Point B corresponds to the moment capacity of the composite cross-section:
 $P^B = 0 \quad (10.75a)$
 $M^B = M_{cp} \quad (10.75b)$
- At point C, the compression and the moment capacities of the composite cross-section are given as follows:
 $P^C = P_{pm} = \alpha_c A_c f_{cu} \quad (10.76a)$
 $M^C = M_{cp} \quad (10.76b)$

The expressions are obtained by combining the stress distributions of the cross-section at points B and C; the compression area of the concrete at point B is equal to the tension area of the concrete at point C. The moment resistance at point C is equal to that at point B since the stress resultants from the additionally compressed parts nullify each other in the central region of the cross-section. However, these additionally compressed regions create an internal axial force which is equal to the plastic resistance to compression of the middle portion of the composite cross-section, P_{pm} over a depth of $2 d_n$, where d_n is the plastic neutral axis distance from the centre-line of the composite cross-section.

- At point D, the plastic neutral axis coincides with the centroidal axis of the composite cross-section and the resulting axial force is half of that at point C.

$$P^D = P_{pm} / 2 \quad (10.77a)$$

$$M^D = M_{cp,max} \quad (10.77b)$$

In general, point D should not be included whenever both N and M cannot be guaranteed to be co-existing all the times.

- Point E is mid-way between points A and C. It is only used in composite cross-sections with concrete infilled hollow sections.
- (3) The influence of transverse shear force on the compression and the moment capacities should be considered if the shear force V_1 acting on the steel section exceeds 50% of the shear capacity V_c of the steel section.
- (4) For simplification, V may be assumed to act on the steel section alone, and the influence of transverse shear forces should be taken into account through a reduced design strength $(1 - \rho) p_y$ in the shear area A_v of the steel section to clause 8.2.1. In all cases, the shear force V_1 shall not exceed the shear capacity of the steel section determined according to clause 8.2.1.

Alternatively, V may be distributed into V_1 acting on the steel section and V_2 acting on the reinforced concrete section. Unless a more accurate analysis is used, the shear forces acting on the steel and the reinforced concrete sections are given by:

$$V_1 = V \frac{M_s}{M_{cp}} \quad (10.78)$$

$$V_2 = V - V_1 \quad (10.79)$$

where

M_s is the moment capacity of the steel section and
 M_{cp} is the moment capacity of the composite section.

The shear capacity V_c of the reinforced concrete section shall be determined in accordance with HKCC.

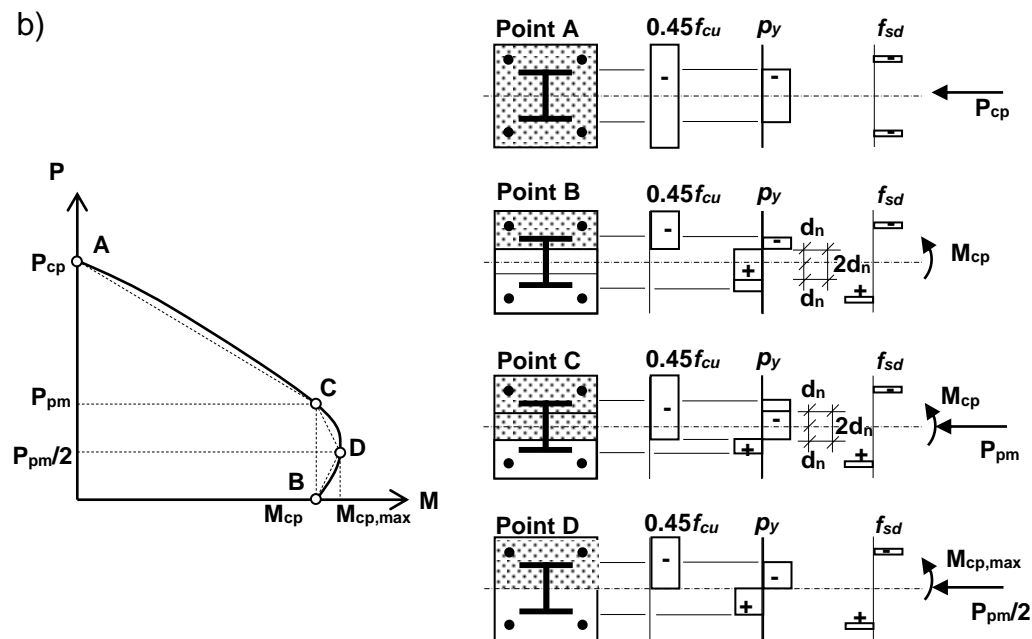
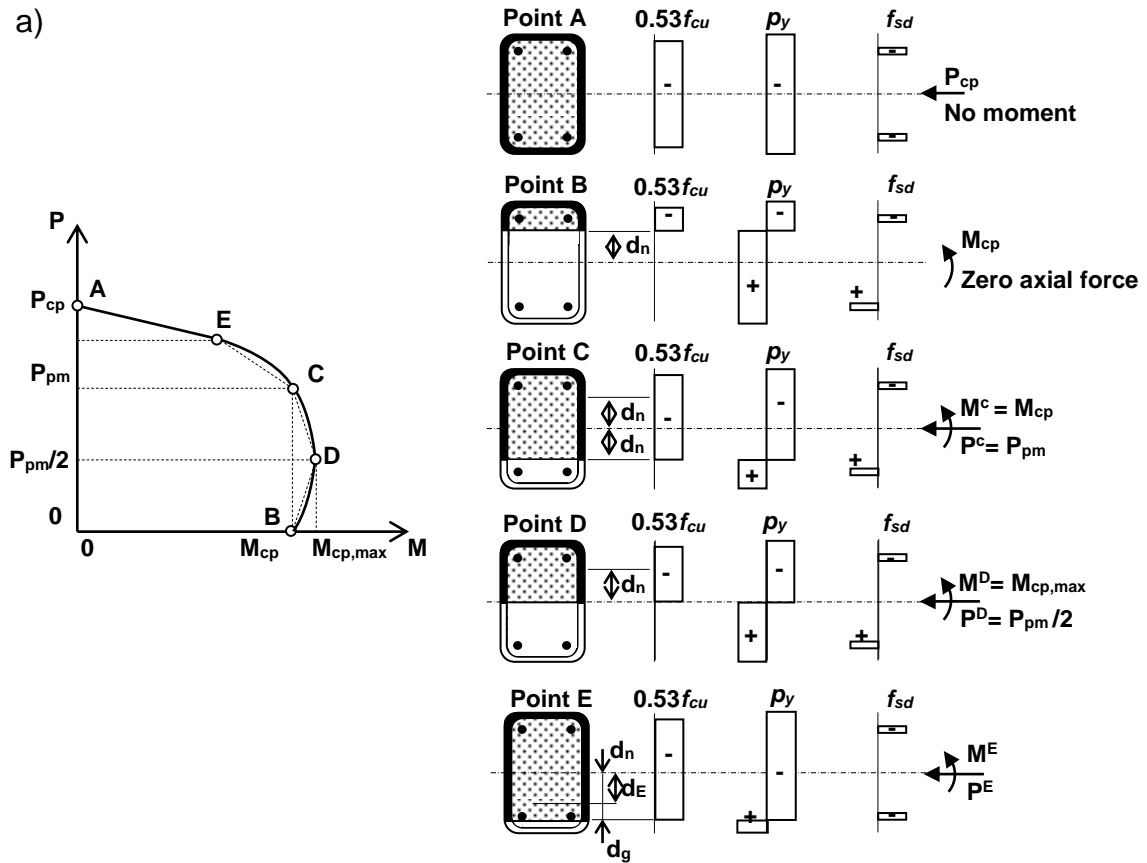

Figure 10.18 - Interaction curves and corresponding stress distributions

NOTE: In general, Point E is not needed for concrete encased I-sections subject to a moment about the major axis, or if the design axial force does not exceed P_{pm} . For concrete infilled hollow sections, the use of point E will give more economical design although much calculation effort is required. For simplicity, point E may be ignored.

- (5) The following expression for local capacity check of composite cross-section shall be satisfied:

$$\frac{M}{M_{cp,P}} = \frac{M}{\mu_d M_{cp}} \leq \alpha_M \quad (10.80)$$

where:

M is the end moment or the maximum bending moment within the column length, calculated according to clause 10.5.3.1(10) to allow for second order effects if necessary;

$M_{cp,P}$ is the moment capacity of composite cross-section taking into account the axial force P , given by $\mu_d M_{cp}$ according to the interaction curve shown in Figure 10.19;

M_{cp} is the moment capacity of composite cross-section, given by point B in Figure 10.18.

μ_d is the reduction factor for moment resistance in the presence of axial force according to the interaction curve shown in Figure 10.19.

α_M is the limiting parameter equal to 0.9 for steel sections with nominal yield strengths between 235 and 355 N/mm² inclusive, and 0.8 for steel sections with nominal yield strength between 420 and 460 N/mm².

Any value of μ_d larger than 1.0 should only be used where the bending moment M depends directly on the action of the normal force P , for example where the moment M results from an eccentricity of the normal force P . Otherwise additional verification is necessary in accordance with clause 10.5.2(6).

- (6) The overall stability of a composite column under combined compression and uni-axial bending based on first order analysis shall be checked as follows:

$$M \leq 0.9 \mu M_{cp} \quad (10.81)$$

where

M is the end moment or the maximum bending moment within the column length, calculated according to clause 10.5.3.1(10) to allow for second order effects if necessary;

μ is the moment resistance ratio after allowing for axial buckling according to the interaction curve shown in Figure 10.19; and

M_{cp} is the plastic moment resistance of the composite cross-section.

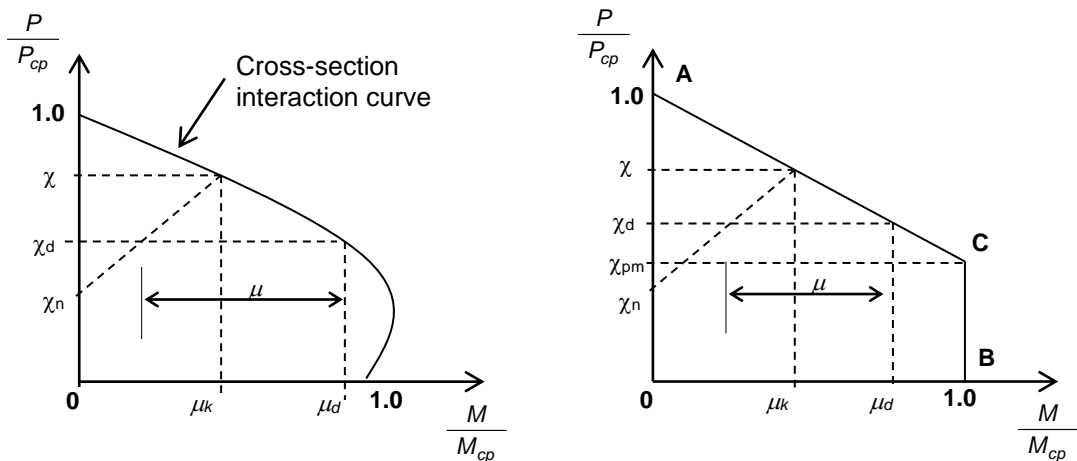

Figure 10.19 - Interaction curve for compression and uni-axial bending

(7) The moment resistance ratio μ shall be evaluated as follows:

$$\mu = \frac{(\chi - \chi_d)(1 - \chi_n)}{(1 - \chi_{pm})(\chi - \chi_n)} \quad \text{when } \chi_d \geq \chi_{pm} \quad (10.82a)$$

$$= 1 - \frac{(1 - \chi)(\chi_d - \chi_n)}{(1 - \chi_{pm})(\chi - \chi_n)} \quad \text{when } \chi_d < \chi_{pm} \quad (10.82b)$$

where

χ_{pm} is the axial resistance ratio due to the concrete given by $\frac{P_{pm}}{P_{cp}}$

χ_d is the design axial resistance ratio given by $\frac{P}{P_{cp}}$

χ is the reduction factor due to column buckling

For fully encased H sections and infilled rectangular hollow sections,

$$\chi_n = \frac{(1 - r)\chi}{4} \quad \text{for } \bar{\lambda} < 1.0 \quad (10.83a)$$

$$= 0 \quad \text{for } 1.0 \leq \bar{\lambda} < 2.0 \quad (10.83b)$$

where r is the ratio of the small to the large end moment. If transverse loads occur within the column height, then r must be taken as unity and χ_n is thus equal to zero.

For infilled circular or square hollow sections

$$\chi_n = \frac{(1 - r)\chi}{4} \quad \text{for } \bar{\lambda} \leq 2.0 \quad (10.84)$$

For infilled hollow sections, the interaction curve of A-E-C-B may be used, especially for columns under high axial load and low end moments. For better approximation, the position of point E may be chosen to be closer to point A rather than being mid-way between points A and C.

For simplicity, the expressions may be modified by taking $\chi_n = 0$.

10.5.3.6 Combined compression and bi-axial bending

(1) For combined compression and bi-axial bending based on first order analysis, both local capacity and overall stability shall be checked.

As an alternative, for composite columns subjected to combined compression and bi-axial bending based on second order analysis, local capacity and overall stability of composite columns shall be checked at the same time provided that all the moments are properly evaluated to include second order moments.

(2) For the design of a composite column under combined compression and bi-axial bending based on first order analysis, structural adequacy of the composite column should be checked as follows:

$$\frac{M_x}{\mu_x M_{cp,x}} \leq \alpha_M \quad (10.85)$$

$$\frac{M_y}{\mu_y M_{cp,y}} \leq \alpha_M \quad (10.86)$$

$$\frac{M_x}{\mu_x M_{cp,x}} + \frac{M_y}{\mu_y M_{cp,y}} \leq 1.0 \quad (10.87)$$

In general, it will be obvious which of the axes is more likely to fail and the imperfections need to be considered for this direction only. If it is not evident which plane is the more critical, checks should be made for both planes.

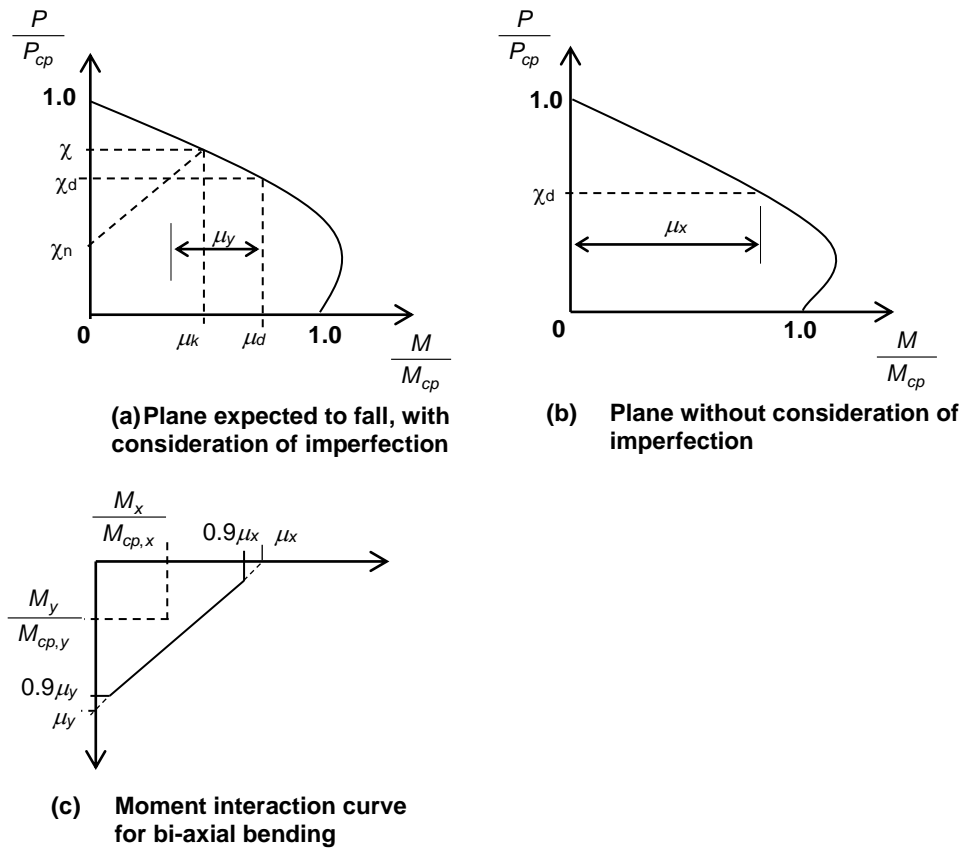

Figure 10.20 - Verification for combined compression and bi-axial bending

As it is only necessary to consider the effect of geometric imperfections in the critical plane of column buckling, the moment resistance ratio μ in the other plane may be evaluated without the consideration of imperfections, which is presented as follows:

$$\mu = \frac{(1 - \chi_d)}{(1 - \chi_{pm})} \quad \text{when } \chi_d > \chi_{pm} \quad (10.88a)$$

$$= 1.0 \quad \text{when } \chi_d \leq \chi_{pm} \quad (10.88b)$$

10.5.4 Shear connection and load introduction

10.5.4.1 General

- (1) Provision shall be made in regions of load introduction for internal forces and moments applied from members connected to the ends and for loads applied within the length to be distributed between the steel and concrete components, considering the shear resistance at the interface between steel and concrete. A clearly defined load path shall be provided that does not involve an amount of slip at this interface that would invalidate the assumptions made in design.
- (2) Where composite columns and compression members are subjected to significant transverse shear, as for example by local transverse loads and by end moments, provision shall be made for the transfer of the corresponding longitudinal shear stress at the interface between steel and concrete.
- (3) For axially loaded columns and compression members, longitudinal shear outside the areas of load introduction need not be considered.

10.5.4.2 Load introduction

- (1) Shear connectors should be provided in the load introduction area and in areas with change of cross section, if the design shear strength τ_{Rd} , see clause 10.5.4.3, is exceeded at the interface between steel and concrete. The shear forces should be determined from the change of sectional forces of the steel or reinforced concrete section within the introduction length. If the loads are introduced into the concrete cross section only, the values shall be obtained from an elastic analysis when the effects from both creep and shrinkage have been allowed for properly. Otherwise, the forces at the interface should be determined by both elastic theory and plastic theory to determine the more severe case.
- (2) In the absence of a more accurate method, the introduction length shall not exceed $2d$ or $L/3$, where d is the minimum transverse dimension of the column and L is the column length.
- (3) For composite columns and compression members, no specific shear connection is needed to be provided for load introduction by endplates if the full interface between the concrete section and the endplate is permanently in compression, after taking proper allowances of both creep and shrinkage. Otherwise, the load introduction should be verified according to clause 10.5.4.2(5). For concrete infilled tubes of circular cross-section the effect caused by the confinement should be taken into account if the conditions given in clause 10.5.3.2(3) are satisfied using the values η_a and η_c for λ equal to zero.
- (4) Where stud connectors are attached to the web of a fully or partially concrete encased steel I-section or a similar section, account shall be taken of the frictional forces that develop from the prevention of lateral expansion of the concrete by the adjacent steel flanges. This resistance shall be added to the calculated resistance of the shear connectors.

The additional resistance shall be assumed to be $0.5 \mu P_p$ on each flange and each horizontal row of studs, as shown in Figure 10.21, where μ is the relevant coefficient of friction. For steel sections without painting, μ shall be taken as 0.5. P_p is the resistance of a single stud in accordance with clause 10.3.2. In the absence of test information, the clear distance between the flanges should not exceed the values given in Figure 10.21.

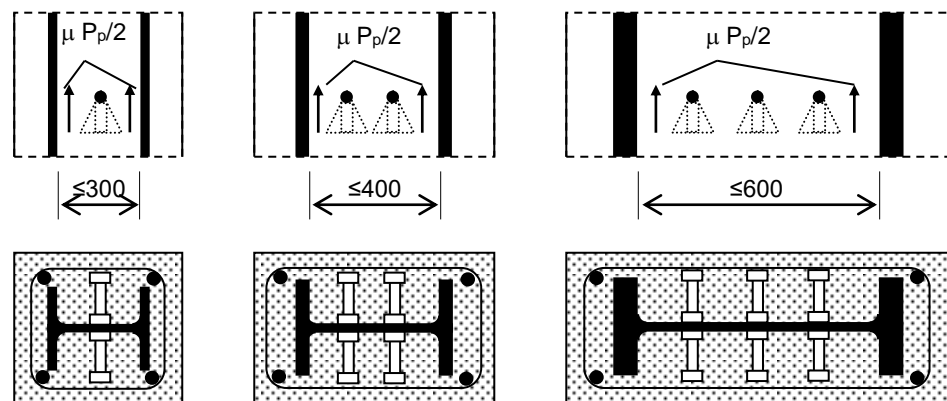

Figure 10.21 - Additional frictional forces in composite columns by use of headed studs

- (5) If the cross-section is partially loaded, the loads shall be distributed with a ratio of 1:2.5 over the thickness t_e of the end plate. The concrete stresses should then be limited in the area of the effective load introduction, for concrete infilled hollow sections in accordance with clause 10.5.4.2(6) and for all other types of cross-sections in accordance with HKCC.

- (6) If the concrete in an infilled circular hollow section or an infilled square hollow section is only partially loaded, for example by gusset plates or by stiffeners through the profile, the local design strength of concrete, σ_c , under the gusset plate or the stiffener resulting from the sectional forces of the concrete section shall be determined as follows:

$$\sigma_c = 0.53 f_{cu} \left[1 + \eta_{cl} \frac{a}{t} \frac{p_y}{0.8 f_{cu}} \right] \sqrt{\frac{A_c}{A_1}} \leq \frac{0.53 A_c f_{cu}}{A_1}, \text{ and } \leq p_y \quad (10.89)$$

where

- t is the wall thickness of the steel tube;
 a is the diameter of the tube or the width of the square section;
 A_c is the cross sectional area of the concrete section of the column;
 A_1 is the loaded area under the gusset plate;
 $\eta_{cl} = 4.9$ for circular hollow sections and 3.5 for rectangular hollow sections.

The ratio A_c/A_1 shall not exceed the value 20. Welds between the gusset plate and the steel hollow sections should be designed according to section 9.

- (7) For concrete infilled circular hollow sections, longitudinal reinforcement may be taken into account for the resistance of the column, even where the reinforcement is not welded to the end plates or in direct contact with the endplates provided that the gap e_g between the reinforcement and the end plate does not exceed 30 mm.
- (8) Transverse reinforcement shall be designed in accordance with HKCC. In case of partially encased steel sections, concrete should be held in place by transverse reinforcement.
- (9) In the case of load introduction through only the steel section or the concrete section in fully encased steel sections, the transverse reinforcement shall be designed for the longitudinal shear that results from the transmission of normal force from the parts of concrete directly connected with shear connectors into the parts of the concrete without direct shear connection.

The design and arrangement of transverse reinforcement shall be based on a truss model assuming an angle of 45° between concrete compression struts and the member axis.

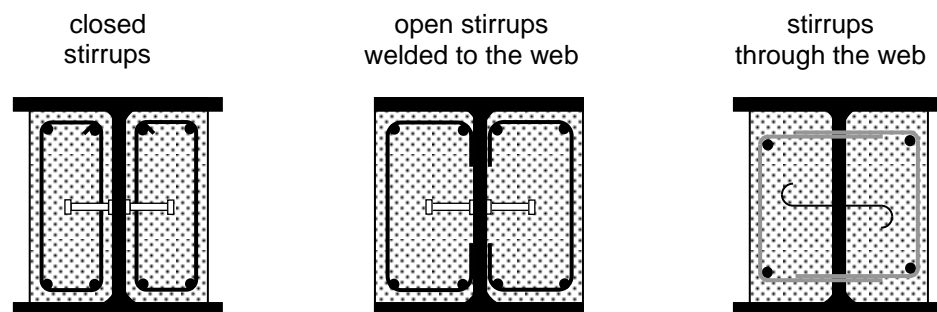

Figure 10.22 - Arrangement of stirrups

10.5.4.3 Longitudinal shear outside the areas of load introduction

- (1) Outside the area of load introduction, longitudinal shear at the interface between concrete and steel shall be verified where it is caused by transverse loads and end moments. Shear connectors shall be provided, based on the distribution of the design value of longitudinal shear, where this exceeds the design shear strength τ .
- (2) In absence of a more accurate method, elastic analysis shall be used to determine the longitudinal shear at the interface with full consideration of long-term effects and cracking of concrete,

- (3) Provided that the surface of the steel section in contact with the concrete is unpainted and free from oil, grease and loose scale or rust, the values given in Table 10.15 should be assumed for τ .

Table 10.15 - Design shear strength τ

Type of cross section	τ (N/mm ²)
Completely concrete encased steel sections	0.30 (minimum)
Concrete infilled circular hollow sections	0.55
Concrete infilled rectangular hollow sections	0.40
Flanges of partially encased sections	0.20
Webs of partially encased sections	0.00

- (4) The value of τ given in Table 10.15 for fully encased H sections applies to sections with a minimum concrete cover of 40 mm and transverse and longitudinal reinforcement in accordance with clause 10.5.5.2. For larger concrete cover and adequate reinforcement, larger values of τ should be used. Unless verified by tests, for completely encased sections, the increased value $\beta_c \tau$ given in Table 10.16 shall be used where β_c is given by:

$$\beta_c = 1 + 0.02c_n \left[1 - \frac{c_{n,min}}{c_n} \right] \leq 2.5 \quad (10.90)$$

where

c_n is the nominal value of concrete cover in mm, see Figure 10.17a;

$c_{n,min}$ is the minimum concrete cover which should be taken at 40 mm.

Table 10.16 - Design shear strength τ_{Rd} for complete concrete encased steel sections

Concrete cover c_n (mm)	$\beta_c \tau$ (N/mm ²)
40	0.30
50	0.36
75	0.51
90	0.60
100	0.66
110	0.72
115 or above	0.75

- (5) Unless otherwise verified by tests, shear connectors should always be provided to partially encased I-sections with transverse shear forces due to bending about the weak axis due to lateral loading or end moments,.

If transverse reinforcement is needed to provide shear resistance in addition to the shear resistance of the structural steel, then the required transverse reinforcement according to clause 10.5.3.5(4) should be welded onto the web of the steel section or should pass through the web of the steel section.

10.5.5 Detailing provisions

10.5.5.1 Concrete cover of steel profiles and reinforcement

- (1) For fully encased H sections, a minimum concrete cover shall be provided to ensure the safe transmission of bond forces, the protection of the steel sections against corrosion, and the spalling of concrete.
- (2) The concrete cover to a flange of a fully encased H section shall not be less than 40 mm, nor less than one-sixth of the breadth b of the flange.
- (3) The concrete cover to reinforcement shall be in accordance with HKCC.

10.5.5.2 *Longitudinal and transverse reinforcement*

- (1) The longitudinal reinforcement in concrete-encased columns which is allowed for in the resistance of the cross-section shall not be less than 0.3% of the cross-section of the concrete. In concrete infilled hollow sections, longitudinal reinforcement is not necessary except for fire resistance design.
- (2) The transverse and longitudinal reinforcement in fully or partially encased columns shall be designed and detailed in accordance with HKCC.
- (3) The clear distance between longitudinal reinforcing bars and the structural steel section may be smaller than that required by clause 10.5.5.2(2), or even zero. In this case, for bonding strength calculation, the effective perimeter c of the reinforcing bars should be taken as half or one quarter of its perimeter, depending on their positions in relation to the steel sections.
- (4) For fully or partially encased members, where environmental conditions are considered as internal, and longitudinal reinforcement is neglected in design, a minimum longitudinal reinforcement of diameter 8 mm at a spacing of 250 mm and a transverse reinforcement of diameter 6 mm at a spacing of 200 mm spacing shall be provided. Alternatively welded mesh reinforcement of diameter 4 mm shall be used.

11 DESIGN OF COLD-FORMED STEEL OPEN SECTIONS, SHEET PROFILES, HOLLOW SECTIONS AND SHEET PILE SECTIONS

This section gives recommendations for the design of cold-formed steel sections.

Clauses 11.1 to 11.6 give recommendations for the design of cold-formed thin gauge steel open sections and sheet profiles with nominal thickness up to 4 mm (This nominal thickness includes the coating, which only applies to thin gauge steel open sections and sheet profiles). Tensile strength and ductility requirements shall comply with clause 11.2.2. The use of these sections and sheet profiles should be either justified by design calculation or by testing. These thin gauge steel open sections and sheet profiles are normally manufactured by cold-rolled forming process. For other manufacturing process such as press-braking process or bend-braking process, the curving or straightening requirements as stipulated in clause 14.2.7 should be complied with.

Clause 11.7 gives recommendations for the design of cold-formed steel hollow sections with nominal thickness up to 22 mm. Clause 11.8 gives recommendations for the design of cold-formed steel sheet pile sections with nominal thickness up to 16 mm. For cold-formed steel open sections and sheet profiles with nominal thickness greater than 4 mm, tensile strength and ductility requirements shall comply with clause 3.1.2.

11.1 GENERAL DESIGN OF OPEN SECTIONS AND SHEET PROFILES

Clauses 11.1 to 11.6 give recommendations for the design of cold-formed thin gauge steel open sections and sheet profiles with nominal thickness up to 4 mm as shown in Figure 11.1.

Design recommendations for thin gauge steel open sections and sheet profiles with the following applications are provided:

Open sections: Secondary structural elements such as purlins and side rails, and primary structural members in trusses and portal frames of modest span.

Sheet profiles: Floor decking as well as roof and wall cladding.

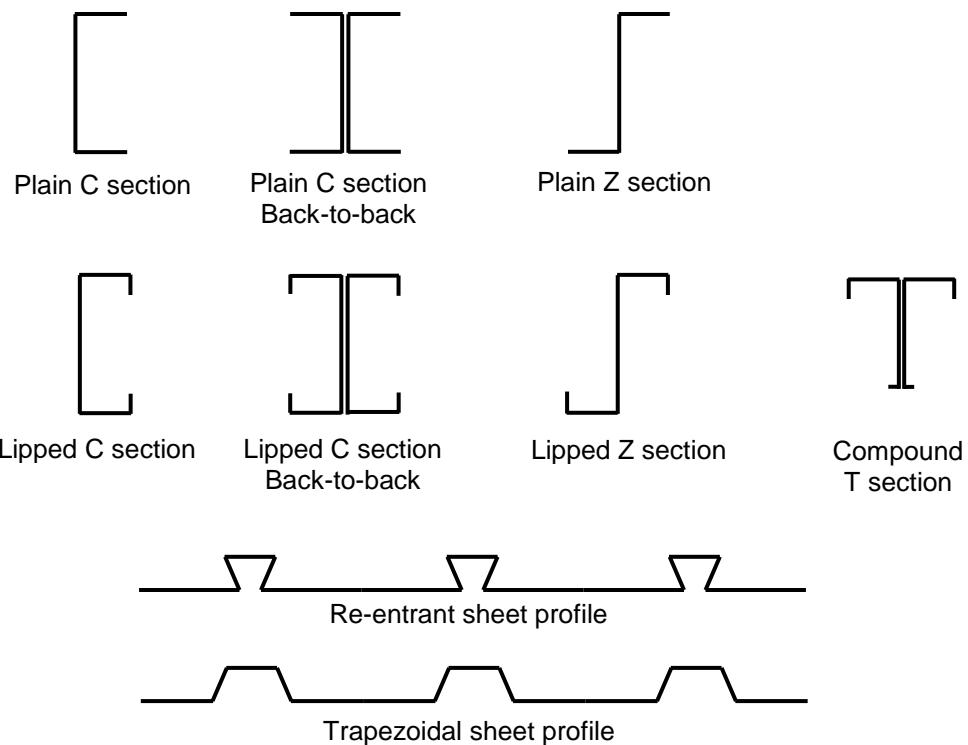

Figure 11.1 - Typical cold-formed steel open sections and sheet profiles

The yield strength of the cold-formed thin gauge steel open sections and sheet profiles shall not be greater than 550 N/mm². For welding of cold-formed steel, refer to Clause 11.7.5 and Table 11.5.

No specific design rules for cold-formed thin gauge steel open sections and sheet profiles with intermediate stiffeners are given this clause. The use of these sections and sheet profiles should be either justified by other established design procedures or by testing.

11.2 MATERIAL PROPERTIES

11.2.1 Physical properties

The physical properties of the steel strips are given in clause 3.1.6.

The design thickness of the material shall be taken as the nominal base metal thickness exclusive of coatings.

11.2.2 Mechanical properties

Both the yield and the tensile strengths, and hence the ductility, of the steel strips with nominal thickness up to 4 mm shall comply with clause 3.8.1.

11.2.2.1 Effects of cold forming

The increase in yield strength due to cold working shall not be utilized for members which undergo welding, annealing, galvanizing or any other heat treatment after forming which may produce weakening.

The increase in yield strength due to cold forming shall be taken into account by replacing the material yield strength, Y_s , by the average yield strength, Y_{sa} , of the sections or the sheet profiles.

For elements under tension, the full effect of cold working on the yield strength shall be used, and thus the design strength, p_y , shall be taken as Y_{sa} .

$$p_y = Y_{sa} \quad (11.1)$$

For elements of flat width, b , and thickness, t , under compression, the design strength, p_y , shall be taken as the average yield strength in compression, Y_{sac} which is given by:

$$p_y = Y_{sac} \quad (11.2)$$

For stiffened elements:

$$Y_{sac} = Y_{sa} \quad \text{for} \quad b/t \leq 24 \varepsilon \quad (11.3a)$$

$$= Y_s \quad \text{for} \quad b/t \geq 48 \varepsilon \quad (11.3b)$$

For unstiffened elements:

$$Y_{sac} = Y_{sa} \quad \text{for} \quad b/t \leq 8 \varepsilon \quad (11.3c)$$

$$= Y_s \quad \text{for} \quad b/t \geq 16 \varepsilon \quad (11.3d)$$

$$\text{where } \varepsilon = \sqrt{\frac{275}{Y_s}} \quad (11.4)$$

For intermediate values of b/t , the value of Y_{sac} shall be obtained by linear interpolation.

The average yield strength, Y_{sa} is given by:

$$Y_{sa} = Y_s + \frac{5Nt^2}{A}(U_s - Y_s) \leq 1.25 Y_s \quad \text{or} \quad \leq U_s \quad (11.5)$$

where

N is the number of full 90° bends in the section with an internal radius $< 5t$ (fractions of 90° bends shall be counted as fractions of N);

t is the net thickness of the steel strip (mm);

U_s is the ultimate tensile strength (N/mm²);

A is the gross area of the cross-section (mm²).

Alternatively, the value of Y_{sa} shall be determined by tests.

11.3 SECTION PROPERTIES

11.3.1 Gross section properties

Section properties shall be calculated according to good practice, taking into account of the sensitivity of the properties of the gross cross-section to any approximations used and their influence on the predicted section capacities and member resistances.

When calculating the section properties of sections up to 3.2 mm thickness, the steel material is assumed to be concentrated at the mid-line of the strip thickness, and the actual round corners are replaced by sharp corners, i.e. intersections of the flat elements, as shown in Figure 11.2a.

When calculating the section properties of sheet profiles up to 2.0 mm thickness, the steel material is assumed to be concentrated at the mid-line of the strip thickness, as shown in Figure 11.2b, provided that the flat width of all the elements is greater than $6.7 r$ where r is the internal corner radius, or $20 t$, whichever is the greatest.

Moreover, the presence of corners and bends shall be allowed for as shown in Table 11.1:

Table 11.1 - Basis for calculation of section properties

Geometrical limits	Basis for calculation
$r \leq 5 t$	Round corners to be replaced with sharp corners, i.e. intersects of flat elements
$5 t < r \leq r_o$	Round corners should be used.
$r > r_o$	Section capacities should be determined by testing.

where r_o is the limiting radius of effective corners
 $= 0.04 t E / p_y$ (11.6)

Hence, the effective width of a flat element, b , shall be generally calculated on the assumption that each element extends to the mid-points of the corners. Refer to clause 11.3.4.4.2 for elements with corners in which r is larger than $5 t$.

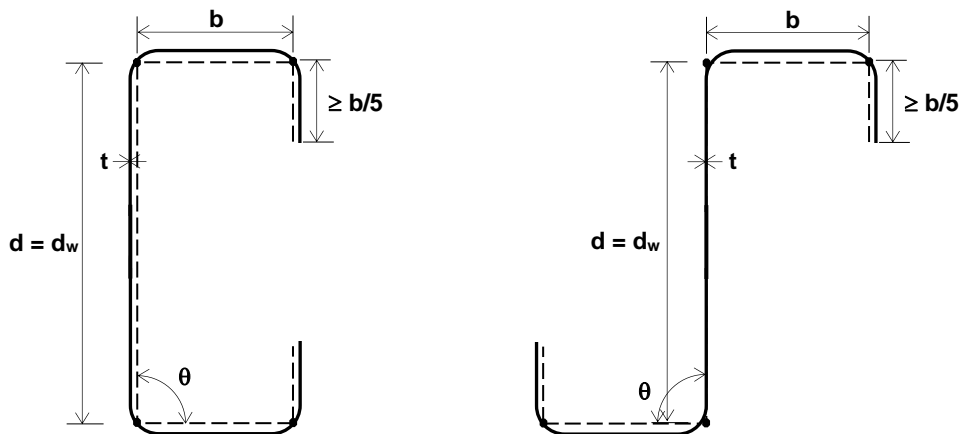

Figure 11.2a - Idealized section for C and Z section



Figure 11.2b - Idealized section for sheet profile

In general, holes for fasteners are not necessary to be deducted when calculating cross-section properties, but allowance shall be made for large openings or arrays of small holes.

The net section properties of sections with regular or irregular arrays of holes, other than

holes required for fastening and filled with bolts, shall be determined by established design procedures or by testing.

11.3.2 Effective section properties under tension

In general, the gross section defined by the mid-line dimensions in clause 11.3.1 shall be adopted.

The effect of bolt holes shall be taken into account in determination of the design strength and stiffness of sections and sheet profiles under tension, and the net area, A_n , shall be taken as the gross area less deductions for holes and openings.

In general, when deducting for holes for fasteners, the nominal hole diameter shall be used. However, for countersunk holes, the area to be deducted shall be the gross cross-sectional area of the hole, including the countersunk portion, in the plane of its axis.

11.3.3 Effective section properties under compression and bending

In general, the gross section defined by the mid-line dimensions in clause 11.3.1 shall be adopted and modified accordingly.

The effects of local buckling shall be taken into account in determination of the design strength and stiffness of sections and sheet profiles under compression and bending. This shall be accomplished by using effective cross-sectional properties which are calculated on the basis of the effective widths of those elements that are prone to local buckling or by the effective stress method.

The effects of intermediate stiffeners and bends shall also be incorporated in determining the effective section properties, as appropriate.

In determining effective section properties for strength assessment, the maximum stresses in flat elements prone to local buckling shall be determined according to the design loads at ultimate limit state, and not exceeding the design strength of the steel material. However, in determining effective section properties for stiffness assessment, the maximum stresses in flat elements prone to local buckling shall be determined according to the design loads at serviceability limit state.

Effective section properties shall be evaluated in accordance with established design procedures. Moreover, the corresponding maximum width-to-thickness ratios shall be observed.

The effect of distortional buckling in sections shall be incorporated, especially in sections and steel profiles with high strength steels. However, it should be noted that for sections and steel profiles with design strengths at 350 N/mm² or below, distortional buckling in sections and steel profiles within the practical ranges of dimensions shall be neglected.

The possible shift of the centroidal axis of the effective cross-section relative to the centroidal axis of the gross cross-section shall be taken into account.

11.3.4 Local buckling

11.3.4.1 General

A rigorous non-linear finite element analysis could be used in determining the resistance of a general cross section. Alternatively, the effects of local buckling in strength and stiffness assessments in sections and sheet profiles shall be allowed for through the use of effective cross sections which comprise of

- a) the effective areas of individual flat elements wholly or partly under compression,
- b) the effective areas of intermediate stiffeners, and
- c) the full areas of individual flat elements under tension.

For a flat stiffened element, the effective area consists of two portions as shown in Figure 11.3a), i.e. one adjacent to each supported edge. Refer to clause 11.3.4.4.3 for details.

For a flat unstiffened element, the whole of the effective area is located adjacent to the supported edge as shown in Figure 11.3b). Refer to clause 11.3.4.4.4 for details.

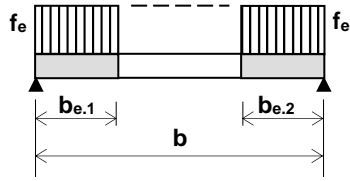

a) Stiffened flange – an element supported at both edges under compression

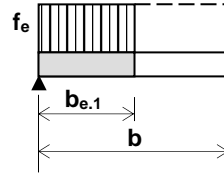

b) Unstiffened flange – an element supported only at one edge under compression

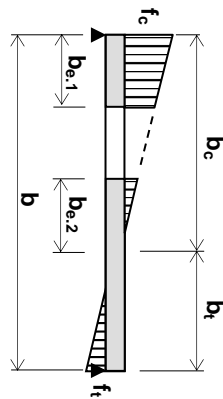

c) Stiffened web – an element supported at both edges under bending

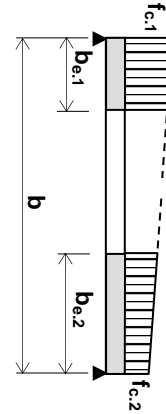

d) Stiffened web – an element supported at both edges under combined compression and bending

Figure 11.3 - Effective width for stiffened and unstiffened elements

11.3.4.2 Maximum width to thickness ratios

For flat elements under compression, the maximum values of element flat width to thickness ratio, $(b/t)_{max}$, covered by the design procedures given in this clause are as follows:

- | | | |
|--|--|----------------|
| (a) Stiffened elements with one edge connected to a flange element or a web element and the other edge supported with: | (i) a simple lip | 60 ϵ |
| | (ii) any other type of stiffener with sufficient flexural rigidity | 90 ϵ |
| (b) Unstiffened elements | | 60 ϵ |
| (c) Stiffened elements with both edges connected to other stiffened elements | | 500 ϵ |

where

$$\epsilon \text{ is } \sqrt{\frac{275}{p_y}};$$

It should be noted that unstiffened compression elements that have width to thickness ratios b/t exceeding 30ϵ and stiffened compression elements that have b/t ratios exceeding 250ϵ are likely to develop noticeable deformations at the full working load, without affecting the ability of the member to carry this load.

11.3.4.3 Stiffened elements under edge stiffener

For a flat element to be considered as a stiffened element under compression, it should be supported along one edge by a flange or a web element, while the other edge supported by (i) a web, (ii) a lip or (iii) other edge stiffener which has adequate flexural rigidity to maintain the straightness of this edge under load.

Irrespective of its shape, the second moment of area of an edge stiffener about an axis through the mid-thickness of the element to be stiffened shall not be less than I_{\min} where I_{\min} is given by:

$$I_{\min} = \frac{t b^3}{375} \quad (11.7)$$

where

b is the width of the element to be stiffened;

t is the thickness.

Where a flat element is stiffened by a simple lip, the lip shall be at an angle of not less than 70° from the element to be stiffened.

Where the stiffener consists of a simple lip at right angles to the element to be stiffened, a width of lip not less than one-fifth of the element width b , as indicated in Figure 11.4, shall be taken as satisfying this condition.

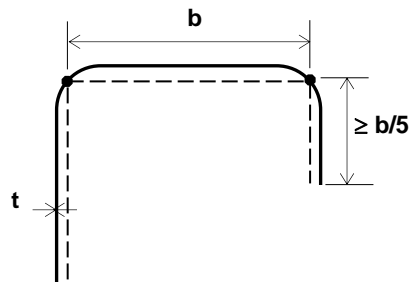

Figure 11.4 - Simple lip edge stiffener

11.3.4.4 Effective width for strength calculation

11.3.4.4.1 Basic effective width

The effective width, b_e , of a flat element under uniform compression with a flat width b is given by:

$$b_e = \beta b \quad (11.8)$$

where

$$\beta = 1.0 \quad \text{when } \rho \leq 0.123 \quad (11.9a)$$

$$= \left\{ 1 + 14(\sqrt{\rho} - 0.35)^4 \right\}^{-0.2} \quad \text{when } \rho > 0.123 \quad (11.9b)$$

where

$$\rho = \frac{f_c}{\rho_{cr}} \quad (11.10)$$

f_c is the applied compressive stress in the effective element; $\leq p_y$

ρ_{cr} is the local buckling strength of the element.

$$= 0.904 E K \left(\frac{t}{b} \right)^2 \quad (11.11)$$

where

K is the relevant local buckling coefficient;

t is the net thickness of the steel material;

b is the flat width of the element.

The local buckling coefficient K depends upon the type of element and also the geometry of the sections and the sheet profiles; refer to clauses 11.3.4.4.3 and 11.3.4.4.4 for details.

11.3.4.4.2 Effect of large radius

When the internal radius r of a corner exceeds $5t$, the effective width of each of the flat elements meeting at that corner should be reduced by $r_m \sin(\theta/2)$, as shown in Figure 11.5.

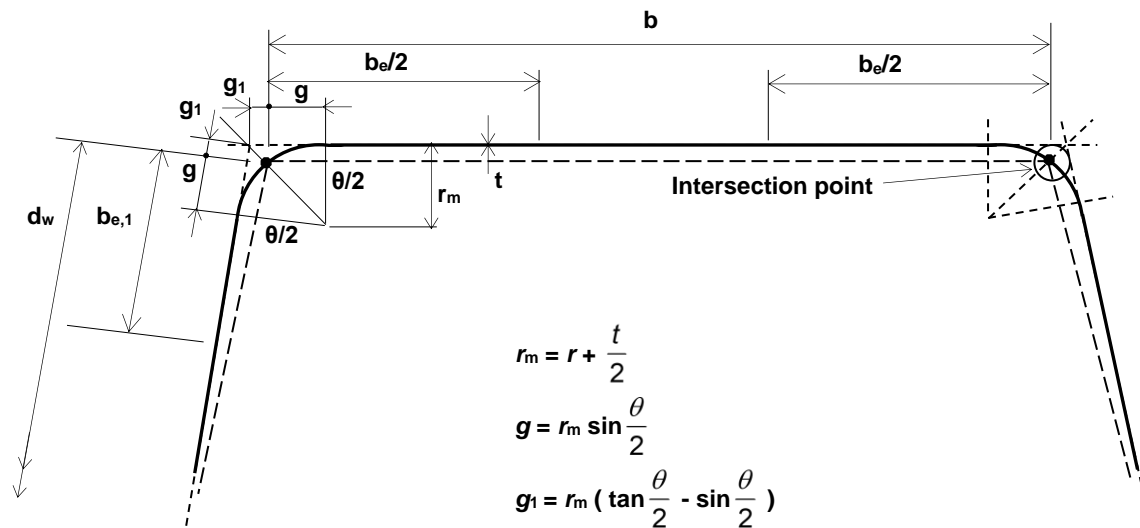

where

- r is the internal bend radius;
- r_m is the mean bend radius;
- t is the steel thickness;
- θ is the angle between the web and the flange;
- g, g_1 are connections to element lengths at corner radii.

Figure 11.5 - Calculation of effective widths allowing for corner radii

11.3.4.4.3 Effective width of a flat stiffened flange element

The effective width of a flat stiffened element forming a compression flange of a section or a sheet profile shall be determined in accordance with clause 11.3.4.4.1, using the appropriate value of K .

For flanges stiffened at both longitudinal edges under uniform compression, the value of the buckling coefficient K shall conservatively be taken as 4. Alternatively, a more precise value of K shall be obtained as follows:

$$K = 5.4 - \frac{1.4h}{0.6+h} - 0.02h^3 \quad \text{for sections} \quad (11.12a)$$

$$= 7 - \frac{1.8h}{0.15+h} - 0.091h^3 \quad \text{for sheet profiles} \quad (11.12b)$$

where

- $h = d_w / b$;
- d_w is the sloping distance between the intersection points of a web and the two flanges;
- b is the flat width of the flange.

11.3.4.4.4 Effective width of a flat unstiffened flange element

The effective width b_{eu} of a flat unstiffened element under uniform compression is given by

$$b_{eu} = 0.89 b_e + 0.11b \quad (11.13)$$

where

- b_e is determined from the basic effective width determined in accordance with clause 11.3.4.4.1;
- b is the flat width of the element.

The value of K shall conservatively be taken as 0.425 for any unstiffened element. Alternatively a more precise value of K shall be obtained as follows:

$$K = 1.28 - \frac{0.8h}{2+h} - 0.0025h^2 \quad (11.14)$$

11.3.4.4.5 Effective width of a flat web element

The web shall be considered to be fully effective when

- i) the web depth to thickness ratio $d_w / t \leq 70 \epsilon$, or
- ii) both edges of the web are under tension.

In all other cases, the effective width of a web in which the stress varies linearly as shown in Figure 11.6, should be obtained in two portions, one adjacent to each edge as follows:

- a) One edge in tension (see Figure 11.6a):

$$b_{e,1} = 0.76t \sqrt{\frac{E}{f_{c,1}}} \quad (11.15a)$$

$$b_{e,3} = 1.5 b_{e,1} \quad (11.15b)$$

where

$b_{e,1}$ is the portion of the effective width adjacent to the more compressed edge;

$b_{e,3}$ is the portion of the effective width adjacent to the tension edge;

$f_{c,1}$ is the larger compressive edge stress;

b_t is the portion of the web under tension;

E is the modulus of elasticity;

t is the net thickness of the steel material.

If $b_{e,1} + b_{e,3} + b_t \geq d_w$, then the web is fully effective, where d_w is the sloping distance between the intersection points of a web and the two flanges.

- b) Both edges in compression (see Figure 11.6b):

$$b_{e,1} = 0.76t \sqrt{\frac{E}{f_{c,1}}} \quad (11.16a)$$

$$b_{e,2} = \left(1.5 - 0.5 \frac{f_{c,2}}{f_{c,1}} \right) b_{e,1} \quad (11.16b)$$

where

$b_{e,1}$ is the portion of the effective width adjacent to the more compressed edge;

$b_{e,2}$ is the portion of the effective width adjacent to the less compressed edge;

$f_{c,1}$ is the larger compressive edge stress;

$f_{c,2}$ is the smaller compressive edge stress;

E is the modulus of elasticity;

t is the net thickness of the steel material.

In both cases, if $b_{e,1} + b_{e,2} \geq d_w$, then the web is fully effective, where d_w is the sloping distance between the intersection points of a web and the two flanges.

If the location of the neutral axis is determined iteratively using effective section properties rather than assuming the web to be fully effective, then $b_{e,1}$ in items a) and b) above should be determined as follows:

$$b_{e,1} = 0.95t \sqrt{\frac{E}{f_{c,1}}} \quad (11.17)$$

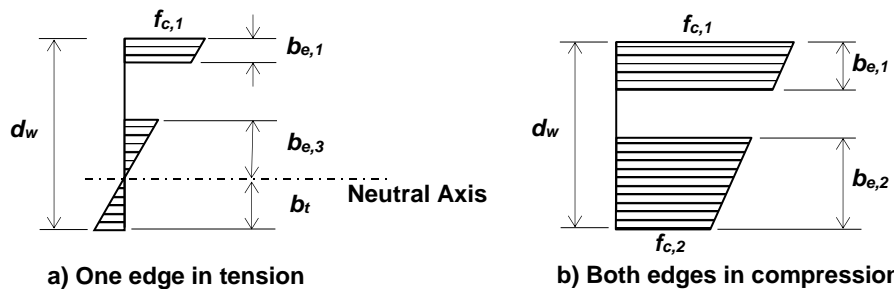

Figure 11.6 - Stress distributions over effective portions of web

11.3.4.5 Effective width for deflection calculation

11.3.4.5.1 Flat flange elements

When calculating deflection, the effective width $b_{e,ser}$ for a stiffened or an unstiffened flat flange element is given by:

$$a) \text{ when } \lambda_{ser} \leq \lambda_1: \quad b_{e,ser} = \frac{1.27 b}{\lambda_{ser}^{2/3}} \text{ but } b_{e,ser} \leq b \quad (11.18a)$$

$$b) \text{ when } \lambda_1 < \lambda_{ser} \leq \lambda: \quad b_{e,ser} = b_{e,1,ser} + (b_e - b_{e,1,ser}) \frac{(\lambda_{ser} - \lambda_1)}{(\lambda - \lambda_1)} \quad (11.18b)$$

where

$$b_{e,1,ser} = \frac{1.27 b}{\lambda_1^{2/3}} \text{ but } b_{e,1,ser} \leq b; \quad (11.19)$$

$$\lambda = \frac{2 b/t}{\sqrt{K}} \sqrt{\frac{\rho_y}{E}}; \quad (11.20)$$

$$\lambda_1 = 0.51 + 0.6\lambda; \quad (11.21)$$

$$\lambda_{ser} = \frac{2 b/t}{\sqrt{K}} \sqrt{\frac{f_{ser}}{E}}; \quad (11.22)$$

b_e is the basic effective width determined in accordance with clause 11.3.4.4.1;
 f_{ser} is the compressive stress in the effective element at serviceability limit state;
 K is the relevant local buckling coefficient determined in accordance with clause 11.3.4.4.3 or 11.3.4.4.4.

11.3.4.5.2 Flat web elements

When calculating deflections, the web shall be considered to be fully effective when

- the web depth to thickness ratio $d_w/t \leq 150\epsilon$, or
- both edges of the web are under tension.

Where this limit is exceeded, the effective width of a web in which the stress varies linearly as shown in Figure 11.6, should be obtained in two portions, one adjacent to each edge as follows:

- One edge in tension (see Figure 11.6a):

$$b_{e,1,ser} = 0.95 t \sqrt{\frac{E}{f_{c,1,ser}}} \quad (11.23a)$$

$$b_{e,3,ser} = 1.5 b_{e,1,ser} \quad (11.23b)$$

where

$b_{e,1,ser}$ is the portion of the effective width adjacent to the more compressed edge;

$b_{e,3,ser}$ is the portion of the effective width adjacent to the tension edge;

$b_{t,ser}$ is the portion of the web under tension at serviceability limit state.

If $b_{e,1,ser} + b_{e,3,ser} + b_t \geq d_w$ where d_w is the sloping distance between the intersection points of a web and the two flanges, then the web is fully effective at serviceability limit state.

- Both edges in compression (see Figure 11.6b):

$$b_{e,1,ser} = 0.95 t \sqrt{\frac{E}{f_{c,1,ser}}} \quad (11.24a)$$

$$b_{e,2,ser} = (1.5 - 0.5 \frac{f_{c,2,ser}}{f_{c,1,ser}}) b_{e,1,ser} \quad (11.24b)$$

where

$f_{c,1,ser}$ is the larger compressive edge at serviceability limit state;

$f_{c,2,ser}$ is the smaller compressive edge at serviceability limit state;

$b_{e,1,ser}$ is the portion of the effective width adjacent to the more compressed edge;

$b_{e,2,ser}$ is the portion of the effective width adjacent to the less compressed edge.

If $b_{e,1,ser} + b_{e,2,ser} \geq d_w$ where d_w is the sloping distance between the intersection points of a web and the two flanges, then the web is fully effective at serviceability limit state.

11.3.5 Flange curling

Sections and sheet profiles with flanges which have high width to thickness ratios b / t are susceptible to exhibit the type of cross-sectional distortion known as 'flange curling' shown in Figure 11.7. Provided that b / t is not greater than 250ϵ for sections and 500ϵ for sheet profiles, the inward movement of each flange towards the neutral axis shall be assumed to be less than $0.05 D_p$, where D_p is the overall depth of the section or the sheet profile, and its occurrence shall be neglected for structural purposes.

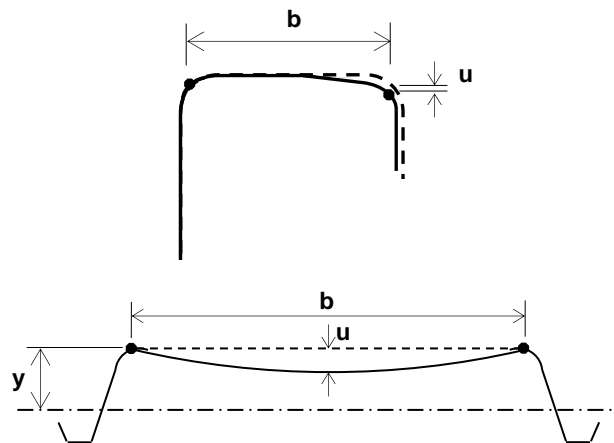

Figure 11.7 - Flange curling

When necessary, the maximum inward movement u of the flange towards the neutral axis should be determined as follows:

$$u = 2 \frac{f_a^2 b_{fc}^4}{E^2 t^2 y} \quad (11.25)$$

where

- f_a is the average stress in the flange;
- b_{fc} is the width of the flange for flange curling as shown in Figure 11.7;
 = the flange width, b , for an unstiffened or edge stiffened flange in sections, or
 = half of the flange width, i.e. $0.5 b$, for a stiffened flange in sheet profiles;
- E is the modulus of elasticity;
- t is the net thickness of steel material;
- y is the distance from the flange to the neutral axis.

This equation is applicable to both compression and tension flanges with or without stiffeners.

NOTE: If the stress in the flange has been calculated on the basis of an effective width, b_e , then f_a can be obtained by multiplying the stress on the effective width by the ratio of the effective flange area to the gross flange area.

11.4 MEMBERS UNDER LATERAL LOADS

11.4.1 General

This clause is concerned with sections and sheet profiles which are subjected to lateral loads, and section capacities against bending, shear and crushing acting separately and in combination.

In general, the moment capacities shall be determined using the non-linear finite element analysis allowing for imperfections and second-order effects could be used in place of the following effective length method or the effective cross sections incorporating the effective areas of those elements partly or wholly in compression and the effective areas of all stiffeners as well as the gross areas of those elements under tension. The moment capacities shall be based on the attainment of a limiting compressive stress equal to the design strength, p_y , in the effective cross sections. For sections or sheet profiles where the webs are only partly effective, iterations shall be performed to locate the actual positions of the neutral axes of the effective cross sections for improved performance.

In cases where the tensile stress reaches the design strength p_y before the compressive stress, plastic redistribution of tensile stresses due to tension yielding shall be taken into account for enhanced capacities.

When calculating deflections, the effective section areas of those elements partly or wholly in compression should be determined under serviceability loads.

11.4.2 Moment capacity

11.4.2.1 Laterally stable beams

This clause is concerned with sections and sheet profiles which are laterally stable. Lateral torsional buckling of sections and sheet profiles shall be checked in accordance with clause 11.4.7.

11.4.2.2 Determination of moment capacity

The effective cross section of a section or a sheet profile comprising flat flange and web elements, as indicated in Figure 11.8, shall be determined as follows.

a) *Effective section with local buckling in compression flange*

The effective section comprises of

- the effective area of the compression flange;
- the gross area of the web; and
- the gross area of the tension flange.

The compression flange shall be supported at both edges, and the effective area shall be determined under a compressive stress f_c equal to the design strength p_y .

b) *Effective section with local buckling in both compression flange and web*

The effective section comprises of

- the effective area of the compression flange;
- the effective area of the web; and
- the gross area of the tension flange.

The effective area of the web shall be determined under a compressive stress f_c equal to the design strength p_y at the flange - web junction. It should be noted that iterations are usually required to locate the actual position of the neutral axis.

The moment capacity M_c is given by:

$$M_c = p_y I_e / y_c \quad \text{if} \quad y_c \geq y_t \quad (11.26a)$$

$$= p_y I_e / y_t \quad \text{if} \quad y_t \geq y_c \quad (11.26b)$$

where

I_e is the second moment of area of the effective cross section which is established in accordance with a) or b) above;

y_c and y_t are as shown on Figure 11.8.

Tension yielding in the web portion under tension, and hence, plastic redistribution of tensile stresses shall be allowed whenever appropriate for increased moment capacities.

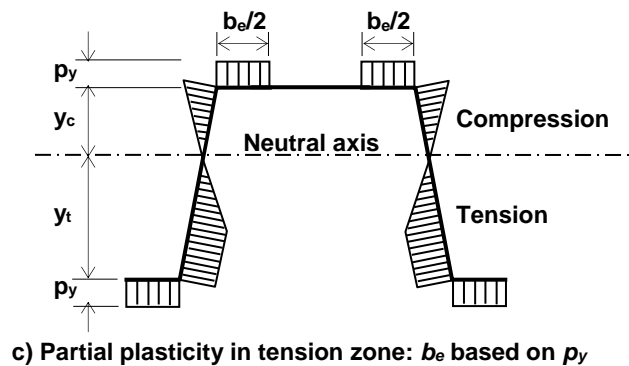
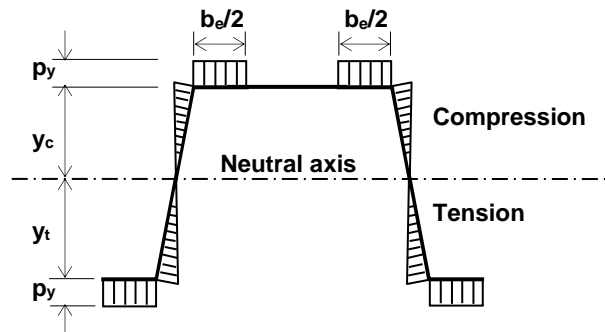
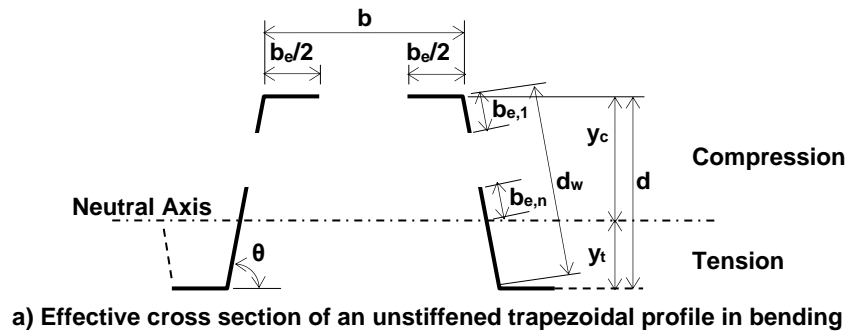

Figure 11.8 - Determination of moment capacity

11.4.3 Shear capacity

11.4.3.1 Sections

The maximum elastic shear stress shall not be greater than $0.7p_y$, where p_y is the design strength.

The average shear strength p_v is given by the lesser of the plastic shear strength, $p_{v,y}$ or the shear buckling strength, $p_{v,cr}$, obtained as follows:

$$p_{v,y} = 0.6 p_y \quad \text{N/mm}^2 \quad (11.27)$$

$$p_{v,cr} = \left(\frac{1000 t}{d_w} \right)^2 \quad \text{N/mm}^2 \quad (11.28)$$

where

p_y is the design strength in N/mm^2 ;

t is the net thickness of the steel material in mm;

d_w is the sloping distance between the intersection points of a web and the two flanges in mm;

d is the overall depth of the section and sheet profile in mm.

The shear capacity of the web in sections, V_c , is given by

$$V_c = p_{v,y} d t \quad \text{but} \quad < p_{v,cr} d t \quad (11.29)$$

11.4.3.2 Sheet profiles

The average shear strength p_v is given by

$$p_v = 0.6 p_y \quad \text{if } \lambda_w \leq 2.33 \quad (11.30a)$$

$$= 1.4 \frac{p_y}{\lambda_w} \quad \text{if } 2.33 < \lambda_w \leq 4.0 \quad (11.30b)$$

$$= 5.6 \frac{p_y}{\lambda_w^2} \quad \text{if } \lambda_w > 4.0 \quad (11.30c)$$

where

λ_w is the web slenderness

$$= \frac{d_w}{t} \sqrt{p_y / E} \quad (11.31)$$

The average shear capacity of the web in sheet profiles is given by

$$V_c = p_v d t \quad (11.32)$$

where

p_v is the shear strength;

t is the net thickness of the steel material;

d_w is the sloping distance between the intersection points of a web and the two flanges;

d is the overall depth of the sheet profile.

11.4.4 Combined bending and shear

For flat webs of sections and sheet profiles subjected to combined bending and shear action, the following equation should be satisfied:

$$a) \quad \frac{V}{V_c} \leq 1 \quad (11.33)$$

$$b) \quad \frac{M}{M_c} \leq 1 \quad (11.34)$$

$$c) \quad \left(\frac{V}{V_c} \right)^2 + \left(\frac{M}{M_c} \right)^2 \leq 1 \quad (11.35)$$

where

V is the applied shear force;

V_c is the shear capacity;

M is the corresponding applied moment acting at the same cross section as V ;

M_c is the moment capacity.

11.4.5 Web crushing capacity

11.4.5.1 Sections

The web crushing capacity of flat section webs, P_w under concentrated forces, either loads or reactions, as shown in Figure 11.9, shall be evaluated using the equations given in Table 11.2a) and Table 11.2b) provided that $45 \leq d/t \leq 200$ and $r/t \leq 6$.

Table 11.2a - Shapes having single thickness webs

Type and position of loadings	Total web resistance, P_w
<p>i) Single load or reaction</p>  <p>$c < 1.5d$. Load or reaction near or at free end</p>	<p>Stiffened flanges</p> $P_w = 1.21 t^2 k_w c_3 c_4 c_{12} \left\{ 2060 - 3.8 \frac{d}{t} \right\} \times \left\{ 1 + 0.01 \frac{N_b}{t} \right\}$ <p>Unstiffened flanges ^a</p> $P_w = 1.21 t^2 k_w c_3 c_4 c_{12} \left\{ 1350 - 1.73 \frac{d}{t} \right\} \times \left\{ 1 + 0.01 \frac{N_b}{t} \right\}$
<p>ii) Single load or reaction</p>  <p>$c < 1.5d$. Load or reaction far from free end</p>	<p>Stiffened and unstiffened flanges ^b</p> $P_w = 1.21 t^2 k_w c_1 c_2 c_{12} \left\{ 3350 - 4.6 \frac{d}{t} \right\} \times \left\{ 1 + 0.007 \frac{N_b}{t} \right\}$
<p>iii) Two opposite loads or reactions $e < 1.5d$</p>  <p>$c \leq 1.5d$. Loads or reactions near or at free end</p>	<p>Stiffened and unstiffened flanges</p> $P_w = 1.21 t^2 k_w c_3 c_4 c_{12} \left\{ 1520 - 3.57 \frac{d}{t} \right\} \times \left\{ 1 + 0.01 \frac{N_b}{t} \right\}$
<p>iv) Two opposite loads or reactions $e < 1.5d$</p>  <p>$c > 1.5d$. Loads or reactions far from free end</p>	<p>Stiffened and unstiffened flanges</p> $P_w = 1.21 t^2 k_w c_1 c_2 c_{12} \left\{ 4800 - 14 \frac{d}{t} \right\} \times \left\{ 1 + 0.0013 \frac{N_b}{t} \right\}$
<p>^a When $\frac{N_b}{t} > 60$, the factor $\left\{ 1 + 0.01 \left(\frac{N_b}{t} \right) \right\}$ shall be increased to $\left\{ 0.71 + 0.015 \left(\frac{N_b}{t} \right) \right\}$</p> <p>^b When $\frac{N_b}{t} > 60$, the factor $\left\{ 1 + 0.007 \left(\frac{N_b}{t} \right) \right\}$ shall be increased to $\left\{ 0.75 + 0.011 \left(\frac{N_b}{t} \right) \right\}$</p>	

Table 11.2b - I-beams and beams with restraint against web rotation

Type and position of loadings	Total web resistance, P_w
<p>i) Single load or reaction</p>  <p>$c < 1.5d$. Load or reaction near or at free end</p>	<p>Stiffened and unstiffened flanges</p> $P_w = t^2 c_7 \rho_y \left\{ 8.8 + 1.1 \sqrt{\frac{N_b}{t}} \right\}$
<p>ii) Single load or reaction</p>  <p>$c < 1.5d$. Load or reaction far from free end</p>	<p>Stiffened and unstiffened flanges</p> $P_w = t^2 c_5 c_6 \rho_y \left\{ 13.2 + 2.87 \sqrt{\frac{N_b}{t}} \right\}$
<p>iii) Two opposite loads or reactions $e < 1.5d$</p>  <p>$c \leq 1.5d$. Loads or reactions near or at free end</p>	<p>Stiffened and unstiffened flanges</p> $P_w = t^2 c_{10} c_{11} \rho_y \left\{ 8.8 + 1.1 \sqrt{\frac{N_b}{t}} \right\}$
<p>iv) Two opposite loads or reactions $e < 1.5d$</p>  <p>$c > 1.5d$. Loads or reactions far from free end</p>	<p>Stiffened and unstiffened flanges</p> $P_w = t^2 c_8 c_9 \rho_y \left\{ 13.2 + 2.87 \sqrt{\frac{N_b}{t}} \right\}$

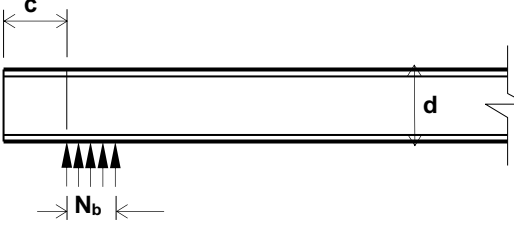
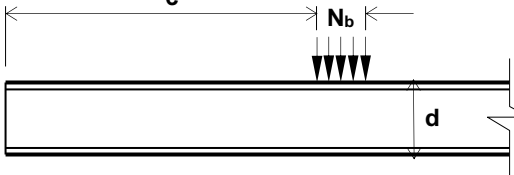
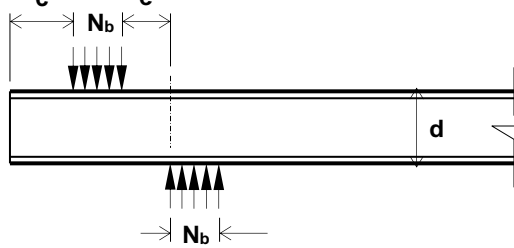
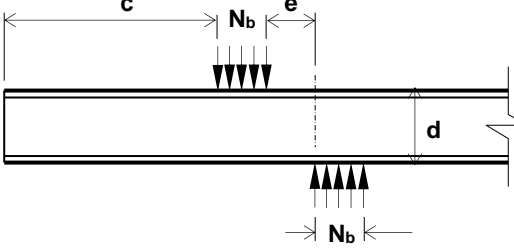
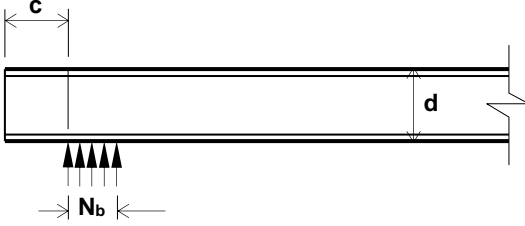
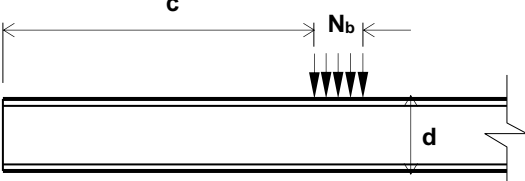
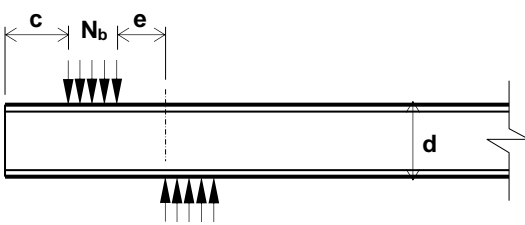
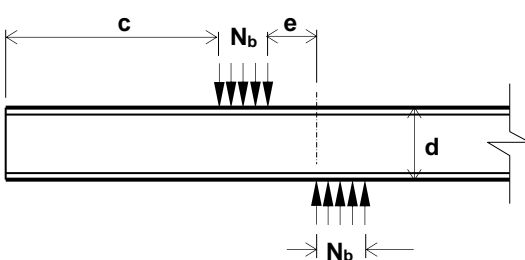
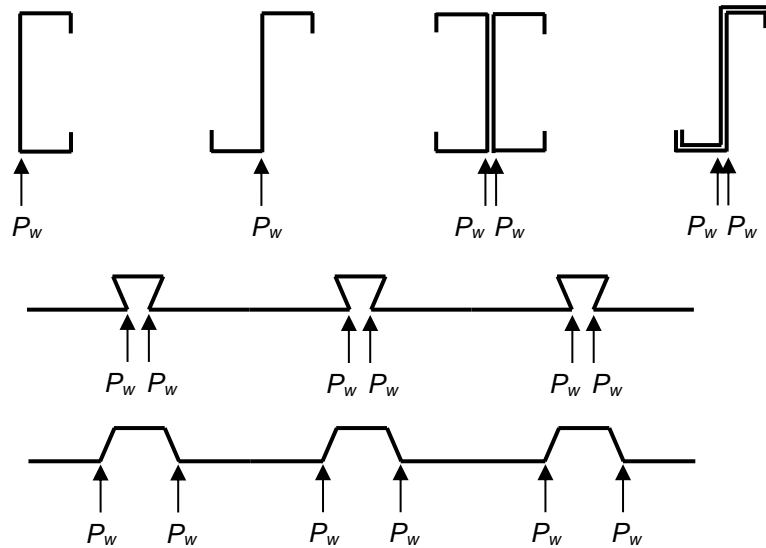

Figure 11.9 - Examples of cross-sections

In these relationships and the equations in Table 11.2a) and Table 11.2b):

d is the overall web depth (mm);
 t is the web thickness (mm);
 r is the internal radius of corner (mm);
 N_b is the length of stiff bearing (mm); for the case of two equal and opposite concentrated loads distributed over unequal bearing lengths, the smaller value of N shall be taken;

P_w is the web crushing capacity of a single web (N);

c is the distance from the end of the section to the load or the reaction (mm);

$$c_1 = 1.22 - 0.27 k_w \quad (11.36a)$$

$$c_2 = 1.06 - 0.06 \frac{r}{t} \leq 1.0 \quad (11.36b)$$

$$c_3 = 1.33 - 0.40 k_w \quad (11.36c)$$

$$c_4 = 1.15 - 0.15 \frac{r}{t} \leq 1.0 \text{ but } \geq 0.5 \quad (11.36d)$$

$$c_5 = 1.49 - 0.64 k_w \geq 0.6 \quad (11.36e)$$

$$c_6 = 0.88 + 0.12 m_w \quad (11.36f)$$

$$c_7 = 1 + \frac{1}{750} \frac{d}{t} \quad \text{when } \frac{d}{t} < 150; \quad (11.36g)$$

$$= 1.20 \quad \text{when } \frac{d}{t} \geq 150 \quad (11.36h)$$

$$c_8 = \frac{0.83}{k_w} \quad \text{when } \frac{d}{t} < 66.5; \quad (11.36i)$$

$$= \frac{0.83 \left(1.10 - \frac{1}{665} \frac{d}{t} \right)}{k_w} \quad \text{when } \frac{d}{t} \geq 66.5 \quad (11.36j)$$

$$c_9 = 0.82 + 0.15 m_w \quad (11.36k)$$

$$c_{10} = \frac{0.83 \left(0.98 - \frac{1}{865} \frac{d}{t} \right)}{k_w} \quad (11.36l)$$

$$c_{11} = 0.64 + 0.31 m_w \quad (11.36m)$$

$$c_{12} = 0.7 + 0.3 \left(\frac{\theta}{90} \right)^2 \quad (11.36n)$$

where

$$k_w = \frac{p_y}{275} \text{ where } p_y \text{ is the design strength (N/mm}^2\text{)}; \quad (11.37)$$

$$m_w = \frac{t}{1.9}; \quad (11.38)$$

θ is the angle in degrees between the plane of web and the plane of bearing surface, where $45^\circ \leq \theta \leq 90^\circ$.

For built-up I-beams, or similar sections, the distance between the connector and the beam flange shall be kept as small as practicable.

11.4.5.2 Sheet profiles

The web crushing capacity of flat profile webs under concentrated forces, either loads or reactions, as shown in Figure 11.9, is given by

$$P_w = 0.15 c_o t^2 \sqrt{E p_y} \left(1 - 0.1 \sqrt{\frac{r}{t}} \right) \left(0.5 + \sqrt{\frac{N_b}{50t}} \right) \left\{ 2.4 + \left(\frac{\theta}{90} \right)^2 \right\} \quad (11.39)$$

where

$c_o = 1.0$ if the nearest edge of the concentrated force is located at a distance of not less than $1.5 d_w$ from the end of the sheet profile;

$c_o = 0.5$ if the nearest edge of the concentrated force is located at a distance of less than $1.5 d_w$ from the end of the sheet profile;

d_w is the sloping distance between the intersection points of a web and the two flanges;

t is the net thickness of steel material;

r is the internal radius of corner;

N_b is the length of stiff bearing, which shall be at least 10 mm but not larger than 200 mm;

E is the modulus of elasticity;

p_y is the design strength of steel;

θ is the inclination of the web ($45^\circ \leq \theta \leq 90^\circ$).

11.4.6 Combined bending and web crushing

For flat webs of sections and sheet profiles subject to combined bending and web crushing action, the following equations should be satisfied:

$$a) \quad \frac{F_w}{P_w} \leq 1.0 \quad (11.40)$$

$$b) \quad \frac{M}{M_c} \leq 1.0 \quad (11.41)$$

$$c) \quad 1.2 \left(\frac{F_w}{P_w} \right) + \left(\frac{M}{M_c} \right) \leq 1.5 \quad \text{for sections having single thickness webs} \quad (11.42a)$$

or

$$1.1 \left(\frac{F_w}{P_w} \right) + \left(\frac{M}{M_c} \right) \leq 1.5 \quad \text{for sections having double thickness webs such as double C sections back-to-back, or similar sections with a high degree of rotational restraint to section webs} \quad (11.42b)$$

or

$$\left(\frac{F_w}{P_w}\right) + \left(\frac{M}{M_c}\right) \leq 1.25 \quad \text{for sheet profiles having single thickness webs} \quad (11.42c)$$

where

F_w is the concentrated force;

P_w is the web crushing capacity;

M is the corresponding applied moment acting at the same cross section as F_w ;

M_c is the moment capacity.

11.4.7 Lateral buckling

11.4.7.1 General

Lateral buckling, also known as lateral-torsional or flexural-torsional buckling, in a member will occur if the member is not adequately restrained against lateral movement and longitudinal twisting. Non-linear finite element analysis allowing for imperfections and second-order effects could be used in place of the following effective length method.

Lateral restraints shall be considered to be fully effective if they are designed against a specific fraction, α , of the maximum force in the compression flange of a member where α is given as follows:

- $\alpha = 3\%$ when only one lateral restraint is attached to the member;
- $\alpha = 1.5\%$ when two lateral restraints are attached to the member;
- $\alpha = 1\%$ when three or more restraints are attached to the member.

Where several members share a common restraint, the lateral restraint should be designed against a total lateral force which is equal to the sum of the largest three.

A compound member composed of two sections in contact or separated back-to-back by a distance not greater than that required for an end gusset connection, shall be designed as a single integral member with an effective slenderness as defined in clause 11.4.7.2, provided that the main components are of a similar cross-section with their corresponding rectangular axes aligned and provided that they are interconnected properly at regular close intervals.

11.4.7.2 Effective lengths

For members susceptible to lateral torsional buckling, the effective length, L_E , shall be taken as follows:

- a) For a member supported at both ends without any intermediate lateral restraint as shown in Figure 11.10, the effective length is given by:
 - 1) $L_E = 1.1 L$ for a member free to rotate in all three directions, i.e. θ_1 , θ_2 and θ_3 directions,
 - 2) $L_E = 0.9 L$ for a member being restrained against torsional rotation θ_1 only,
 - 3) $L_E = 0.8 L$ for a member being restrained against torsional rotation θ_1 , and rotation about the minor axis θ_2 ,
 - 4) $L_E = 0.7 L$ for a member being fully restrained against rotation in all three directions, i.e. θ_1 , θ_2 and θ_3 directions.

where L is the span of the member between end supports.

- b) For a member attached to intermediate restraints through substantial connections to other steel members which is part of a fully framed structure, L_E shall be taken as 0.8 times the distance between intermediate restraints.

For a member attached to intermediate restraints through less substantial connections, L_E shall be taken as 0.9 times the distance between intermediate restraints.

- c) Where the length considered is the length between an end support and an intermediate restraint, the effective length coefficient shall be taken as the mean of the values obtained from a) and b) above.
- d) In the case of a compound member composed of two C sections back-to-back designed as a single integral member with sufficient interconnections, the effective slenderness of the compound member $(L_E/r_y)_e$ shall be calculated as follows:

$$\left(\frac{L_E}{r_y}\right)_e = \sqrt{\left(\frac{L_E}{r_{cy2}}\right)^2 + \left(\frac{s}{r_{cy1}}\right)^2} \geq 1.4 \frac{s}{r_{cy}} \quad (11.43)$$

where

- L_E is the effective length of the compound member;
- r_y is the radius of gyration of the compound member about the axis parallel to the webs allowing for the two sections acting as a single integral member;
- r_{cy2} is the radius of gyration of the compound member about the axis parallel to the webs based on nominal geometric properties;
- s is the longitudinal spacing between adjacent interconnections which shall not exceed $50 r_{cy}$;
- r_{cy1} is the minimum radius of gyration of an individual C section.

The strength and the maximum spacing of interconnections shall comply with clause 11.6.4.

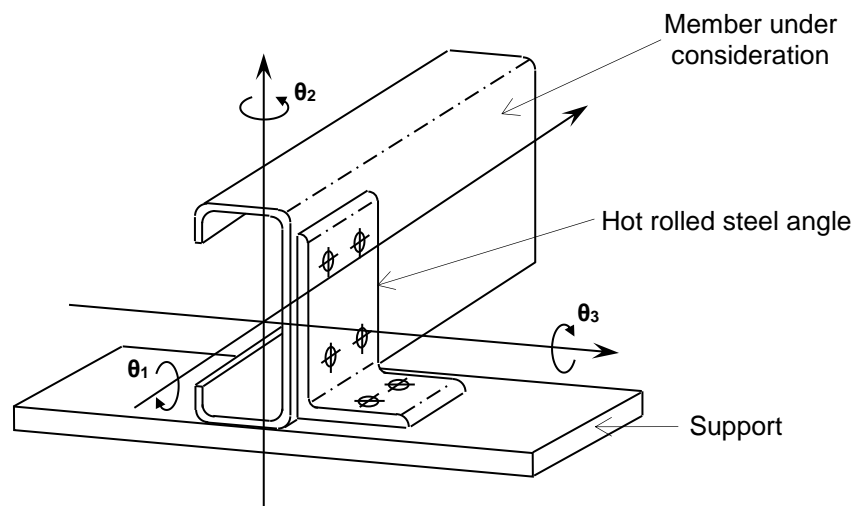

Figure 11.10 - Restraint condition for lateral buckling

11.4.7.3 Destabilizing loads

The condition of a destabilizing load exists when a load is applied to a member where both the load and the member are free to deflect laterally and twist longitudinally relative to the centroid of its cross section. In such cases, the effective lengths given in clause 11.4.7.2 should be increased by 20%.

11.4.7.4 Buckling moment resistance

11.4.7.4.1 Buckling resistance moment M_b

In each segment of a beam, the buckling resistance moment M_b shall satisfy the following equation:

$$m_{LT} M_x \leq M_b \quad \text{and} \quad M_x \leq M_c \quad (11.44)$$

where

m_{LT} is the equivalent uniform moment factor for lateral torsional buckling of simple beams in Table 8.4, or conservatively taken as unity. For cantilever, m_{LT} is equal to 1.

M_x is the maximum bending moment along the beam segment.

$$M_b \quad \text{is the buckling moment resistance of a member with insufficient lateral restraint}$$

$$= \frac{M_E M_Y}{\phi_B + \sqrt{\phi_B^2 - M_E M_Y}} \leq M_c \quad (11.45)$$

where

$$\phi_B = \frac{M_Y + (1 + \eta) M_E}{2} \quad (11.46)$$

M_c is the moment capacity of the member determined in accordance with clause 11.4.2.2;

M_Y is the elastic yield moment resistance of the member
 $= p_y \times Z_{gc}$;

Z_{gc} is the elastic modulus of the gross cross-section with respect to the compression flange;

M_E is the elastic lateral buckling moment resistance determined in accordance with clause 11.4.7.4.2;

η is the Perry coefficient
 $= 0$ when $L_E / r_y \leq 40$ (11.47a)

$$= 0.002 \left(\frac{L_E}{r_y} - 40 \right) \quad \text{when } L_E / r_y > 40 \quad (11.47b)$$

where

L_E is the effective length determined in accordance with clause 11.4.7.2;

r_y is the radius of gyration of the member about the y axis.

11.4.7.4.2 Determination of M_E

The elastic lateral buckling moment resistance, M_E , for members loaded effectively through the shear centre of their cross sections shall be determined as follows:

a) for members of single C sections, compound C sections back-to-back and equal flange I-section bent in the plane of the web:

$$M_E = \frac{\pi^2 A E d}{2(L_E / r_y)^2} C_{tw} \quad (11.48a)$$

If the member is torsionally restrained at the cross-sections at both the load application and the support points, it should be considered to be loaded through the shear centre for determination of M_E .

b) for members of Z sections bent in the plane of the web:

$$M_E = \frac{\pi^2 A E d}{4(L_E / r_y)^2} C_{tw} \quad (11.48b)$$

c) for members of T sections bent in the plane of the web:

$$M_E = \frac{\pi^2 A E d}{2(L_E / r_y)^2} C_T [\bar{C}_{tw} + 1] \quad \text{when the flanges are in compression} \quad (11.48c)$$

$$= \frac{\pi^2 A E d}{2(L_E / r_y)^2} C_T [\bar{C}_{tw} - 1] \quad \text{when the flanges are in tension} \quad (11.48d)$$

where

A is the cross-sectional area of the member;

E is the modulus of elasticity;

d is the overall web depth;

$$C_{tw} = \sqrt{\left\{ 1 + \frac{1}{20} \left(\frac{L_E t}{r_y d} \right)^2 \right\}} ; \quad (11.49a)$$

$$\bar{C}_{tw} = \sqrt{\left\{1 + \frac{1}{20} \left(\frac{1}{C_T} \frac{L_E t}{r_y d} \right)^2\right\}}; \quad (11.49b)$$

$$C_T = \frac{1 + 1.5 \frac{B}{d} - 0.25 \left(\frac{B}{d} \right)^3}{1 + 2 \frac{B}{d}}; \quad (11.49c)$$

where

B is the total width of the flange of a T-section;

t is the net thickness of steel material;

L_E and r_y are as defined in clause 11.4.7.4.1.

It should be noted that if a negative value of C_T is obtained, the member should be regarded as fully restrained.

C_{tw} may conservatively be taken as 1.0 for members in a) and b) above.

11.4.8 Calculation of deflection

11.4.8.1 General

Deflections should be calculated using elastic analysis. Due allowance shall be made for the effects of non-uniform loading. The effective cross section for deflection calculations shall be determined in accordance with clause 11.3.4.7. In the absence of more accurate analysis and information, the effective second moment of area I_{ser} of open section and sheet profiles shall be assumed to be constant throughout each span.

Recommended deflection limits are given in clause 5.2.

11.4.8.2 Single spans

For a uniformly loaded single span, the deflection δ is given by

$$\delta = \frac{5}{384} \frac{w L^4}{E I_{ser}} \quad (11.50)$$

where

w is the intensity of loading at serviceability limit state;

L is the span between centres of supports;

I_{ser} is the effective second moment of area of the open section and sheet profiles at serviceability limit state, determined at midspan.

11.4.8.3 Multi-spans

11.4.8.3.1 Type of loading

When calculating deflections due to imposed gravity loads, the possibility of pattern loading between different spans should be considered.

However when calculating deflections of sheet profiles used as permanent shuttering for slabs, the weight of the wet concrete should be taken as uniformly distributed on all spans.

Uniform loading on all spans should also be taken when calculating deflections of cladding and roof decking subject to wind load only.

11.4.8.3.2 Calculation of deflection

Unless a more detailed analysis is undertaken, the following approximations may be assumed to cover the extent of loading most likely to be met in practice, providing that the spans do not vary by more than 15% of the greatest spans.

The maximum deflection due to uniformly distributed load on all spans is given by

$$\delta = \frac{1}{185} \frac{w L^4}{E I_{ser}} \quad (11.51)$$

The maximum deflection δ due to pattern loading is given by

$$\delta = \frac{3}{384} \frac{w L^4}{E I_{ser}} \quad (11.52)$$

where

L is the greatest span between centres of supports.

11.4.9 Effects of torsion

For members of open sections, the effects of torsion should be avoided whenever possible either by providing sufficient restraints designed to resist twisting or by ensuring that all lateral loads are applied through the shear centres of the members.

11.4.9.1 Direct stresses due to combined bending and torsion

For members subjected to combined bending and torsion, the maximum stress due to both effects combined, determined on the basis of the gross section and the unfactored loads, shall not exceed the design strength, p_y .

11.4.9.2 Angle of twist

The angle of twist of a member which is subject to torsion shall not be so great as to change significantly the shape of the cross-section or its capability to resist bending.

11.5 MEMBERS UNDER AXIAL LOADS

11.5.1 Members under tension

In general, advanced analysis, second-order analysis or the non-linear finite element analysis allowing for imperfections and second-order effects could be used in place of the following effective length method.

11.5.1.1 Tensile capacity

The tensile capacity, P_t , of a member is given by:

$$P_t = A_{net} p_y \quad (11.53)$$

where

p_y is the design strength.

A_{net} is the effective net area of a section or a sheet profile

$$= A_c + A_u \frac{A_c}{(A_c + A_u/3)} \quad (11.54a)$$

for single angles connected through one leg only, single C and Z sections connected only through the web, and T sections connected only through the flange, or

$$= A_c + A_u \frac{A_c}{(A_c + A_u/5)} \quad (11.54b)$$

for double angles, C and T sections connected back-to-back

where

A_c is the net sectional area of the connected leg;

A_u is the gross sectional area of the unconnected leg or legs.

It should be noted that

- a) for double angles connected to one side of a gusset or section, the angles shall be designed individually.
- b) for double angles, C and T sections connected back-to-back, the two components shall be
 - 1) in direct contact, or separated by solid packing pieces by a distance not exceeding the sum of the thickness of the parts; and

- 2) inter-connected by bolts such that the slenderness of the individual components does not exceed 80.

These rules only apply when the width to thickness ratios of the unconnected elements are less than 20. For width to thickness ratios greater than 20, the nominal moment due to eccentricity of applied forces should be taken into account.

In determining the net gross area of a connected leg, the area to be deducted from the gross sectional area should be the maximum sum of the sectional areas of the holes in any cross-section at right angles to the direction of stress in the member.

However, when the holes are staggered, the area to be deducted should be the greater of:

- the deduction for non-staggered holes;
- the sum of the sectional areas of all holes in any zigzag line extending progressively across the member or part of the member, less $s_p^2 t / 4 g$ for each gauge space in the chain of holes.

where

s_p is the staggered pitch, i.e. the distance measured parallel to the direction of stress in the member centre-to-centre of holes in consecutive lines (see Figure 11.11);

t is the net thickness of the steel material;

g is the gauge, i.e. the distance measured at right angles to the direction of stress in the member centre-to-centre of holes in consecutive lines (see Figure 11.11).

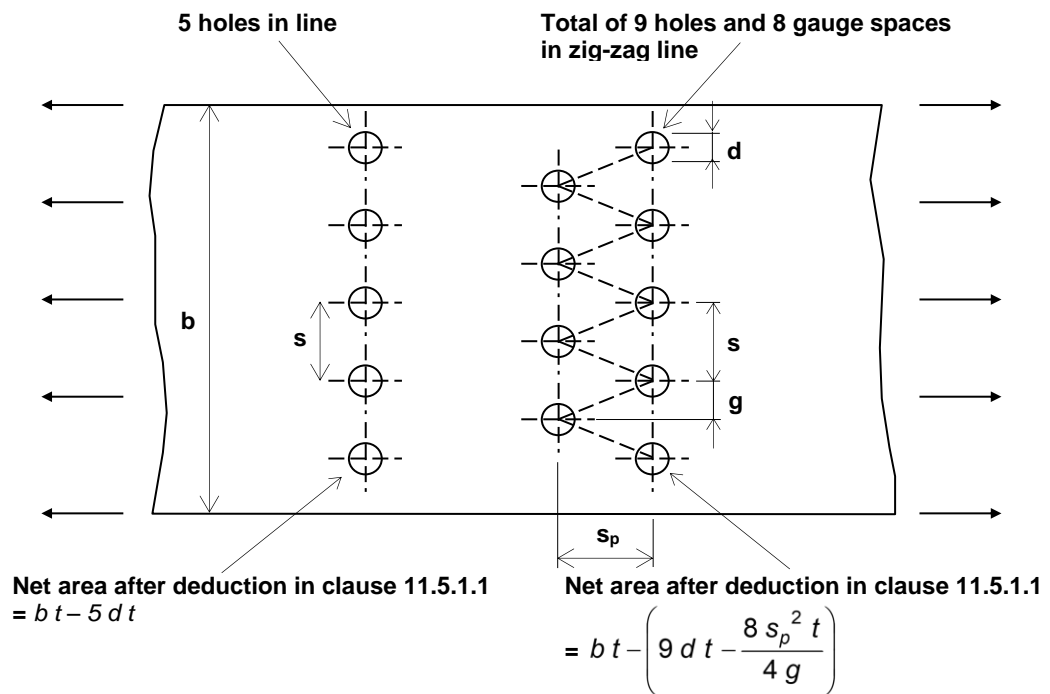

Figure 11.11 - Nomenclature for staggered holes with example

11.5.1.2 Combined tension and bending

For members subject to combined tension and bending, the following equation shall be satisfied:

$$a) \quad \frac{F_t}{P_t} \leq 1 \quad (11.55)$$

$$b) \quad \frac{M_x}{M_{cx}} \leq 1 \quad (11.56)$$

$$c) \quad \frac{M_y}{M_{cy}} \leq 1 \quad (11.57)$$

$$d) \quad \frac{F_t}{P_t} + \frac{M_x}{M_{cx}} + \frac{M_y}{M_{cy}} \leq 1 \quad (11.58)$$

where

F_t is the applied tensile force

P_t is the tensile capacity determined in accordance with clause 11.5.1.1;

M_x is the applied moment about the x axis;

M_y is the applied moment about the y axis;

M_{cx} is the moment capacity under pure bending about the x axis; and

M_{cy} is the moment capacity under pure bending about the y axis.

11.5.2 Members under compression

11.5.2.1 Compressive capacity

The compressive capacity, P_{cs} , of a member is given by:

$$P_{cs} = A_e p_y \quad (11.59)$$

where

p_y is the design strength;

A_e is the area of the effective cross section of the member under compression determined after full consideration against local buckling to clause 11.3.4.

11.5.3 Flexural buckling

11.5.3.1 Effective lengths

The effective length of a member in compression shall be established in accordance with clause 8.7.2 and Table 8.6 or on the basis of good engineering practice.

11.5.3.2 Maximum slenderness

In general, the slenderness ratio shall be taken as the effective length, L_E , divided by the radius of gyration of the gross cross-section about the relevant axis, r . The maximum value of the slenderness ratio, L_E/r , shall not exceed:

- 180 for members resisting loads other than wind loads;
- 250 for members resisting self weight and wind loads only;
- 350 for any member acting normally as a tie but subject to reversal of stress resulting from the action of wind.

11.5.3.3 Ultimate loads

For members with cross sections symmetrical about both principal axes or closed cross-sections which are not subject to flexural-torsional buckling, or members which are braced against twisting, the compressive buckling resistance, P_c , is given by:

$$P_c = \frac{P_E P_{cs}}{\phi + \sqrt{\phi^2 - P_E P_{cs}}} \quad (11.60)$$

where

$$\phi = \frac{P_{CS} + (1 + \eta)P_E}{2} \quad (11.61)$$

where

P_E is the minimum elastic buckling load

$$= \frac{\pi^2 EI}{L_E^2} \quad (11.62)$$

where

E is the modulus of elasticity;

I is the second moment of area of the cross-section about the critical axis;

L_E is the effective length of the member about the critical axis;

η is the Perry coefficient, such that

$$= 0 \quad \text{for } L_E / r \leq 20 \quad (11.63a)$$

$$= 0.002 (L_E / r - 20) \quad \text{for } L_E / r > 20 \quad (11.63b)$$

r is the radius of gyration of the gross cross-section corresponding to P_E .

It should be noted that for members susceptible to flexural-torsional buckling, P_E shall be multiplied with the flexural-torsional buckling parameter α_{TF} which is determined in accordance with clause 11.5.4.1. For bi-symmetrical cross sections, α_{TF} is equal to unity.

11.5.3.4 Singly symmetrical sections

For members with cross sections symmetrical about only a single axis and which are not subject to flexural-torsional buckling, or which are braced against twisting, the effects of the shift of the neutral axis shall be taken into account in evaluation of the maximum compressive resistance.

The shift of the neutral axis shall be calculated by determining the neutral axis position of the gross cross-section and that of the effective cross-section. In evaluation of the neutral axis position of the effective cross-section, the effective portions shall be positioned as detailed in clause 11.3.3 and shown in Figure 11.12.

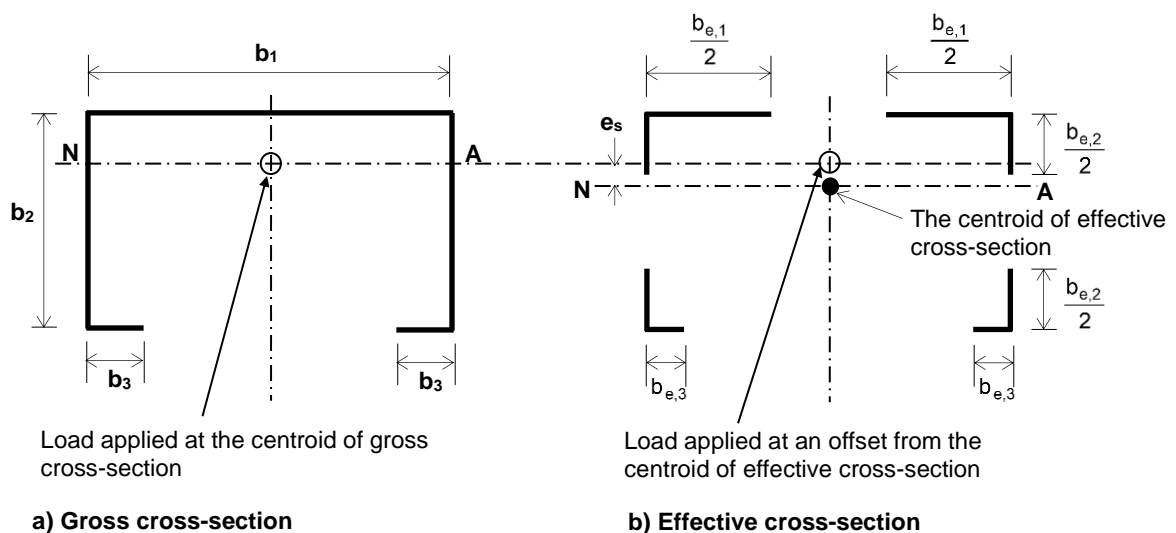

Figure 11.12 - Compression of singly symmetrical section

The modified compressive buckling resistance, P'_c , of the member is then given by

$$P'_c = \frac{M_c}{(M_c + P_c e_s)} P_c \quad (11.64)$$

where

M_c is the moment capacity determined in accordance with clause 11.4.2.2, having due regard to the direction of moment application as indicated in Figure 11.12;

P_c is the compressive buckling resistance of the member determined in accordance with clause 11.5.3.3;

e_s is the distance between the neutral axis of the gross cross-section and that of the effective cross-section, as indicated in Figure 11.12.

11.5.3.5 Compound members composed of C sections back-to-back

A compound member composed of two C sections in contact or separated back-to-back by a distance not greater than that required for an end gusset connection, should be designed as a single integral member subject to the following conditions:

- The C sections are similar in cross-section with their corresponding rectangular axes aligned.
- The C sections are interconnected with structural fasteners in accordance with clause 11.6.
- The effective slenderness of the compound member $(L_E / r_y)_e$ about the axis parallel to the webs of the C sections, is given by

$$\left(\frac{L_E}{r_y} \right)_e = \sqrt{\left(\frac{L_E}{r_{cy2}} \right)^2 + \left(\frac{s}{r_{cy1}} \right)^2} \geq 1.4 \frac{s}{r_{cy1}} \quad (11.65)$$

where

L_E is the effective length of the compound member;

r_y is the radius of gyration of the compound member about the axis parallel to the webs allowing for the two sections acting as a single integral member;

r_{cy2} is the radius of gyration of the compound member about the axis parallel to the webs based on nominal geometric properties;

s is the longitudinal spacing between adjacent interconnections which shall not exceed $50 r_{cy1}$;

r_{cy1} is the minimum radius of gyration of an individual C section.

The strength and the maximum spacing of interconnections is given in clause 11.6.

11.5.4 Flexural-torsional buckling

The design procedure given in clause 11.5.4.1 applies only to members which are braced in both the x and the y directions at the ends or at the same points of supports of the members.

11.5.4.1 Sections with at least one axis of symmetry (x axis)

For members which have at least one axis of symmetry, taken as the x axis, and which are subject to flexural-torsional buckling, and designed according to clause 11.5.3, the value of α_{TF} is given by:

$$\text{for } P_E \leq P_{TF} \quad \alpha_{TF} = 1 \quad (11.66a)$$

$$\text{for } P_E > P_{TF} \quad \alpha_{TF} = \sqrt{\frac{P_E}{P_{TF}}} \quad (11.66b)$$

where

P_E is the elastic flexural buckling load for a member under compression:

$$= \frac{\pi^2 EI}{L_E^2} \quad (11.67)$$

where

E is the modulus of elasticity;

I is the second moment of area about the y axis;

L_E is the effective length corresponding to the minimum radius of gyration;

P_{TF} is the flexural-torsional buckling load of a member under compression:

$$= \frac{1}{2\beta} \left[(P_{Ex} + P_T) - \sqrt{(P_{Ex} + P_T)^2 - 4\beta P_{Ex} P_T} \right] \quad (11.68)$$

where

P_{Ex} is the elastic flexural buckling load for the member about the x axis:

$$= \frac{\pi^2 EI_x}{L_E^2} \quad (11.69)$$

P_T is the elastic torsional buckling load of the member:

$$= \frac{1}{r_o^2} \left(GJ + \frac{2\pi^2 EC_w}{L_{EZ}^2} \right) \quad (11.70)$$

$$\beta = 1 - \left(\frac{e_{sc}}{r_o} \right)^2 \quad (11.71)$$

L_{EZ} is the effective length of the member against torsion and warping;

r_o is the polar radius of gyration about the shear centre:

$$= \sqrt{r_x^2 + r_y^2 + e_{sc}^2} \quad (11.72)$$

r_x, r_y are the radii of gyration about the x and y axes;

G is the shear modulus;

e_{sc} is the distance from the shear centre to the centroid measured along the x axis;

J is the St Venant torsion constant

$$= \sum \frac{bt^3}{3}$$

where b is the element flat width and t is the net thickness of the steel material;

I_x is the second moment of area about the x axis;

C_w is the warping constant of the cross-section.

11.5.4.2 Non-symmetrical sections

For members with non-symmetrical cross-sections, the maximum load shall be determined either by advanced analysis or by testing.

11.5.5 Combined compression and bending

In general, advanced analysis, second-order analysis or the non-linear finite element analysis allowing for imperfections and second-order effects could be used in place of the following effective length method.

When designed by the effective length method, members under combined compression and bending shall be checked for local capacities and overall buckling resistances.

Clauses 11.5.5.1 and 11.5.5.2 apply to members which have at least one axis of symmetry and which are not subject to torsional or flexural-torsional buckling.

11.5.5.1 Local capacity check

The following check against local capacities shall be satisfied at various points along the length of the members:

$$\frac{F_c}{P_{cs}} + \frac{M_x}{M_{cx}} + \frac{M_y}{M_{cy}} \leq 1 \quad (11.73)$$

where

F_c is the applied compression force;

P_{cs} is the compression capacity;

M_x is the applied moment about the x axis;

M_y is the applied moment about the y axis;

M_{cx} is the moment capacity under pure bending about the x axis in accordance with clause 11.4.2.2;

M_{cy} is the moment capacity under pure bending about the y axis in accordance with clause 11.4.2.2.

11.5.5.2 Overall buckling check

a) For members not subject to lateral buckling, the following simplified check shall be satisfied:

$$\frac{F_c}{P_c} + \frac{m_x M_x}{M_{cx}} + \frac{m_y M_y}{M_{cy}} \leq 1 \quad (11.74)$$

b) For members subject to lateral buckling, the following simplified check shall be satisfied:

$$\frac{F_c}{P_{cy}} + \frac{m_{LT} M_{LT}}{M_b} + \frac{m_y M_y}{M_{cy}} \leq 1 \quad (11.75)$$

where

P_c is the compressive buckling resistance;

M_b is the buckling moment resistance about the x (major) axis as defined in clause 11.4.7.4;

F_c , M_x , M_{cx} , M_y and M_{cy} are as defined in clause 11.5.5.1.

The magnitudes of moments M_x and M_y shall take into account any moment induced by the shift of the neutral axis caused by the compression force.

m_{LT} is the equivalent uniform moment factor for lateral torsional buckling over the segment length L_{LT} governing M_b from Table 8.4;

m_x is the equivalent uniform moment factor for major axis flexural buckling over the segment length L_x governing P_{cx} from Table 8.9;

m_y is the equivalent uniform moment factor for minor axis flexural buckling over the segment length L_y governing P_{cy} from Table 8.9;

L_{LT} is the segment length between restraints against lateral torsional buckling;

L_x is the segment length between restraints against flexural buckling about the major axis;

L_y is the segment length between restraints against flexural buckling about the minor axis.

For members subject to significant P- Δ - δ effect, refer to clause 8.9.2.

11.6 CONNECTIONS

11.6.1 General recommendations

This clause provides detailed design recommendations on connections and fastenings with the following types of fasteners:

- Bolts
- Screws and blind rivets

Design of interconnections in forming an I-section using two C sections back-to-back and bolted moment connections of an I-section using two C sections back-to-back are also provided.

In general, connections and fastenings shall be designed using a realistic assumption of the distribution of internal forces, taking into account of relative stiffnesses. This distribution shall correspond with direct load paths through the elements of connections. It is essential that equilibrium with the applied forces is maintained. Ease of fabrication and erection shall be considered in the design of joints and splices. Attention shall be paid to clearances necessary for tightening of fasteners, subsequent inspection, surface treatment and maintenance.

As ductility of steel assists the distribution of local forces generated within a joint, residual stresses and stresses due to tightening of fasteners with normal accuracy of fit-up shall be ignored.

11.6.1.1 Intersections

Usually, members meeting at a joint shall be arranged with their centroidal axes meeting at a point. Where there is eccentricity at intersections, both the members and the connections shall be designed to accommodate the resulting moments. In the case of bolted framing of angles and tees, the setting-out lines of the bolts shall be adopted instead of the centroidal axis.

11.6.1.2 Strength of individual fasteners

The strength of individual fasteners shall be calculated in accordance with clause 11.6.2 or 11.6.3, or determined by testing.

11.6.1.3 Forces in individual fasteners

The shear forces on individual fasteners in a connection shall be assumed to be equal provided that the material is less than or equal to 4 mm thick. Otherwise the shear forces on individual fasteners shall be calculated by elastic analysis.

11.6.2 Fastenings with bolts

The recommendations in this clause apply to bolts with a diameter d in the range:

$$10 \text{ mm} \leq d \leq 30 \text{ mm} \quad (11.76)$$

The recommendations are applicable to bolts in nominally 2 mm oversize clearance holes.

11.6.2.1 Effective diameter and areas of bolts

The tensile stress area of the bolt, A_t , shall be used in determining the shear and the tensile capacities of a bolt. For bolts without a defined tensile stress area, A_t shall be taken as the area at the bottom of the threads.

Where it is shown that the threads do not occur in the shear plane, the shank area, A , shall be used in the calculation of shear capacity.

In the calculation of thread length, allowance shall be made for tolerance and thread run off.

11.6.2.2 Shear and tension capacities of bolts

The shear capacity, P_s , of a bolt is given by:

$$P_s = p_s A_s \quad (11.77)$$

The tension capacity, P_t , of a bolt is given by:

$$P_t = p_t A_t \quad (11.78)$$

where

A_s is A_t or A as appropriate as defined in clause 11.6.2.1;

p_s is the shear strength given in Table 11.3;

p_t is the tensile strength given in Table 11.3.

Table 11.3 - Design strength of bolts in clearance holes

	General grade of bolts	Common bolt grade	
		M4.6	M8.8
Shear strength, p_s (N/mm ²)	0.48 U_{fb} but $\leq 0.69 Y_{fb}$	160	375
Tensile strength, p_t (N/mm ²)	0.58 U_{fb} but $\leq 0.83 Y_{fb}$	195	450

Notes: Y_{fb} is the specified minimum yield strength of bolts;
 U_{fb} is the specified minimum tensile strength of bolts.

11.6.2.3 Combined shear and tension

When bolts are subject to combined shear and tension, the following relationship shall be satisfied in addition to the recommendations in clause 11.6.2.2:

$$\frac{V}{V_c} + \frac{F_t}{P_t} \leq 1.4 \quad (11.79)$$

where

V is the applied shear force;

F_t is the applied tension force;

V_c is the shear capacity of bolt determined in accordance with clause 11.6.2.2;

P_t is the tension capacity of bolt determined in accordance with clause 11.6.2.2.

11.6.2.4 Minimum pitch, and minimum edge and end distances

For steel materials less than or equal to 4 mm thick, the distance between the centres of adjacent bolts in the line of force, or the bolt pitch, shall not be less than $3d$, where d is the diameter of the bolt. For steel materials greater than 4 mm thick, the bolt pitch shall not be less than $2.5d$.

The distance between the centre of a bolt and any edge of the connected member, i.e. the edge distances and the end distances shall not be less than $1.5d$.

11.6.2.5 Bearing capacity

The bearing capacity, P_{bs} , of connected elements for each bolt in the line of force is given by:

$$P_{bs} = \alpha \rho d t p_y \quad (11.80)$$

where

α is the strength coefficient which is given as follows:

i) for $t \leq 1$ mm

$$\alpha = 2.1 \quad (11.81a)$$

ii) for $1 < t \leq 3$ mm

$$\alpha = 2.1 + \left(0.3 \frac{d_e}{d} - 0.45 \right) (t - 1) \quad \text{when } \frac{d_e}{d} < 3 \quad (11.81b)$$

$$= 1.65 + 0.45t \quad \text{when } \frac{d_e}{d} \geq 3 \quad (11.81c)$$

iii) for $3 < t \leq 8$ mm

$$\alpha = 1.2 + 0.6 \frac{d_e}{d} \quad \text{when } \frac{d_e}{d} < 3 \quad (11.81d)$$

$$= 3.0 \quad \text{when } \frac{d_e}{d} \geq 3 \quad (11.81e)$$

$\rho = 1.0$ when washers are used under both the bolt heads and the nuts;

$\rho = 0.75$ when only a single washer or no washer is used;

d is the nominal diameter (mm);

t is the net thickness of the steel material (mm);
 p_y is the design strength (N/mm²); and
 d_e is the distance from the centre of a bolt to the end of the connected element in the direction of the bolt force (mm).

11.6.2.6 Tensile strength on net section

The tensile strength, p_t , of the net area of an element in a bolted connection is given by:

$$p_t = p_y \quad \text{or} \quad (11.82a)$$

$$= (0.1 + 3 \frac{d}{s}) p_y \quad (11.82b)$$

where:

p_y is the design strength (N/mm²);

d is the diameter of the bolt (mm);

s is the distance between centres of bolts normal to the line of force (see Figure 11.11) or, where there is only a single line of bolts, the width of sheet (mm).

11.6.2.7 Prying

In connections subject to tension, prying action should be ignored provided that the design strengths of bolts given in Table 11.3 are used.

11.6.3 Fastenings with screws and blind rivets

This clause applies to self-tapping screws, including thread-forming, thread-cutting or self-drilling screws, and to blind rivets with a diameter d in the range of:

$$3.0 \text{ mm} \leq d \leq 7.5 \text{ mm} \quad (11.83)$$

If components of different thickness are connected, the head of the screw or the preformed head of the rivet shall be in contact with the thinner component.

The diameter of pre-drilled holes shall follow strictly in accordance with the manufacturer's recommendations.

Both the shear capacity, P_s , and the tensile capacity, P_t , of screws and rivets shall be determined by testing or provided by manufacturer. In order to avoid brittle failure, the size of the fastener shall be such that P_{fs} is not less than $1.25 P_s$ and P_{ft} is not less than $1.25 P_t$ where P_s and P_t are the shear and the tensile forces acting onto the fastener.

11.6.3.1 Minimum pitch, and minimum edge and end distances

The distance between centres of fasteners shall be not less than $3d$.

The distance from the centre of a fastener to the edge of any part shall not be less than $3d$.

If the connection is subjected to force in one direction only, such as to cause shear force in the fastener, the minimum edge distance shall be reduced to $1.5d$ or 10 mm, whichever is the smaller, in the direction normal to the line of force.

11.6.3.2 Capacity against shear force

The shear capacity, P_s , of a screw or a rivet in tilting and bearing is given by:

a) for $\frac{t_4}{t_3} = 1.0$,

$$P_s = 3.2 \sqrt{t_3^3 d} p_y \leq 2.1 t_3 d p_y \quad (11.84a)$$

b) for $\frac{t_4}{t_3} \geq 2.5$,

$$P_s = 2.1 t_3 d p_y \quad (11.84b)$$

For $1.0 < \frac{t_4}{t_3} < 2.5$, P_s shall be determined by linear interpolation between the results obtained from a) and b) above.

where

- t_3 is the thickness of the element in contact with the screw head or the preformed rivet head;
 t_4 is the thickness of the element remote from the screw head or the preformed rivet head;
 d is the diameter of the fastener;
 p_y is the design strength of the element material.

11.6.3.3 Capacity against tensile force

For screws which carry significant tensile forces, the head of the screw, or the washer, if present, shall have an overall diameter d_w of at least 8 mm and shall have adequate rigidity. However, blind rivets shall not be used to carry significant tensile forces.

The tensile capacity P_t of a screwed connection shall be taken as the smallest of the following:

- a) pulling of the connected element over the screw head or washer:

For connected element of thickness t_1 less than 2.0 mm and washer size d_w less than 25 mm,

$$P_t = 1.1 t_1 d_w p_y \quad (11.85)$$

where

d_w is the diameter of the washer;

t_1 is the thickness of the element in contact with the screw head or the preformed rivet head. For other configurations, the tensile capacity shall be determined by testing.

- b) pull out from the base element:

For connected element of thickness t_2 larger than 0.9 mm,

$$P_t = 0.65 d t_2 p_y \quad (11.86)$$

where

t_2 is the thickness of the element remote from the screw head or preformed rivet head.

11.6.4 Interconnections in compound members

11.6.4.1 Maximum pitch: compression members

The distance between centres, in the line of force, of fasteners connecting a compression cover plate or sheet to a non-integral stiffener or other element shall not exceed any of the following:

- a) the spacing required to transmit the shear force between the connected parts;

- b) $37 t \varepsilon$ where t is the thickness of the cover plate or sheet in mm, and $\varepsilon = \sqrt{\frac{275}{Y_s}}$

where Y_s is the yield strength of the cover plate or sheet in N/mm²;

- c) three times the flat width of the narrowest unstiffened compression element in that portion of the cover plate or sheet which is adjacent to the connection, or $30 t \varepsilon$ whichever is greater.

11.6.4.2 Maximum pitch: connections of two C sections back-to-back to form an I-section

For compound members composed of two C sections back-to-back, interconnected by structural fasteners, either the individual sections shall be designed between points of interconnection in accordance with clauses 11.4 and 11.5 as appropriate, or the compound member shall be designed as a single integral member on the basis of an effective slenderness as defined in clause 11.4.7.2d) provided the longitudinal spacing s of the interconnections complies with the following.

- a) For a compression member, designed in accordance with clause 11.5, at least two fasteners shall be provided in line across the width of all members that are sufficiently wide to accommodate them. Moreover, the spacing of interconnections,

s, shall be such that

i) the member length is divided into at least three parts of approximately equal length;

ii) $s \leq 50 r_{cy1}$ (11.87)

where

s is the longitudinal spacing of interconnection;

r_{cy1} is the minimum radius of gyration of an individual C section.

The interconnecting structural fasteners shall be designed to transmit the longitudinal shear force, F_s , between the C sections induced by a transverse shear force, V , at any point in the compound member. The value of V shall be taken as not less than 2.5% of the design axial force in the compound member plus any load due to its self weight or wind load. The resulting longitudinal shear force per interconnection is given by:

$$F_s = \frac{V}{4} \left(\frac{s}{r_{cy1}} \right) \quad (11.88)$$

where

s / r_{cy1} is the local slenderness of an individual C section as given in clause 11.4.7.2d).

b) For a flexural member designed in accordance with clause 11.4, at least two structural fasteners shall be provided in line across the width of all members as shown in Figure 11.13. The tendency of the individual C sections to separate by twisting shall be resisted by limiting the spacing of interconnection, s , such that:

i) the member length is divided into at least three parts of approximately equal length;

ii) $s \leq 50 r_{cy1}$ (11.89)

where

s is the longitudinal spacing of interconnections;

r_{cy1} is the minimum radius of gyration of an individual C section.

iii) the tensile capacity, P_t of the individual interconnection is greater than the induced transverse shear force, F_s :

$$P_t \geq F_s$$

where

$$F_s = \frac{F e}{2 h} \quad (11.90)$$

e is the distance between the shear centre of the C section and the mid-plane of the web;

h is the vertical distance between the two rows of fasteners near or at the top and the bottom flanges;

F is the local concentrated force or the reaction force between the points of interconnection under consideration; or, for distributed load $F = w s$;

w is the load intensity on the member acting on a bearing length of $s/2$ each side of the interconnection under consideration.

The maximum spacing of interconnections depends on the load intensity acting at the connection. Therefore, if uniform spacing of connections is used over the whole length of the member, it shall be determined at the point of maximum local load intensity. If, however, this procedure results in uneconomically close spacing, then either the spacing shall be varied along the member length according to the variation of the load intensity, or reinforcing cover plates shall be provided to the flanges at the points where concentrated loads or reaction forces occur. The shear strength of the connections joining such plates to the flanges shall then be used for P_t , and h in the equation should be taken as the depth of the beam.

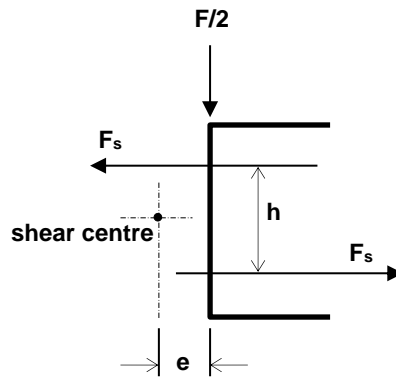

Figure 11.13 - Connection forces in back-to-back members

11.6.5 Bolted moment connections of compound members

For compound members composed of two C sections back-to-back with sufficient interconnections, bolted moment connections using fabricated inverted T sections as column bases and gusset plates as beam-column connections are shown in Figure 11.14.

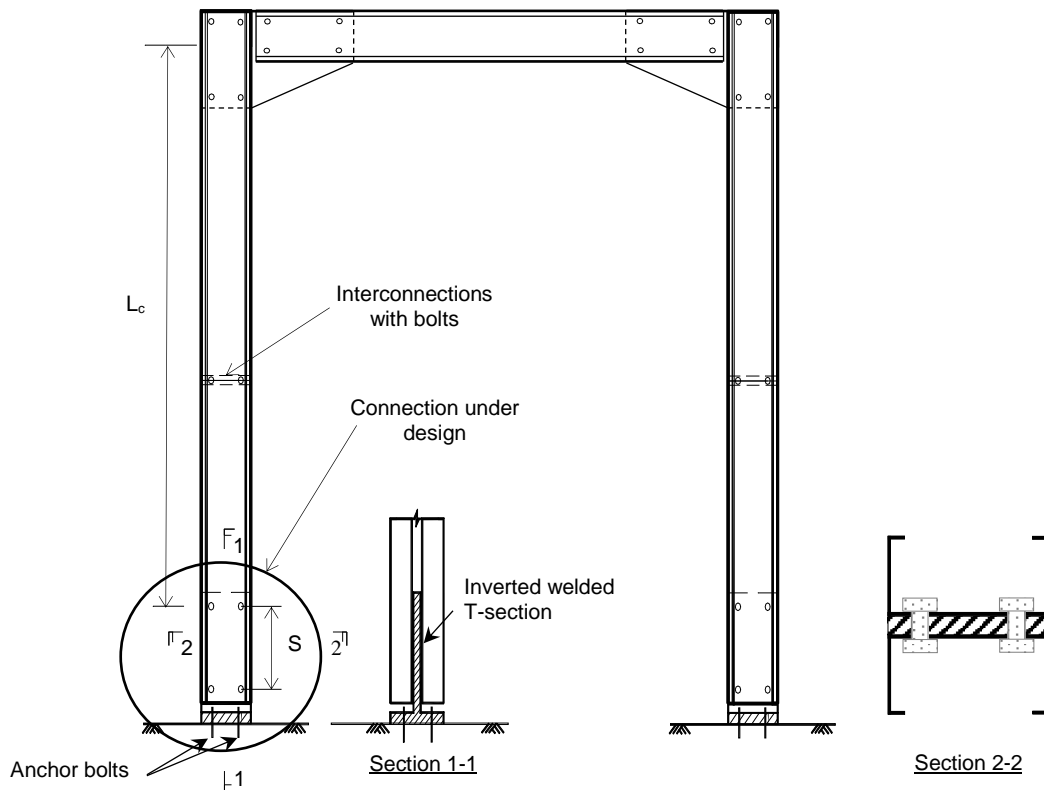

Figure 11.14 - Typical bolted moment connection

Both fabricated T-section and anchor bolt shall be designed in accordance with clause 9.4 while the force distribution within the bolted connections shall be determined through force and moment equilibrium consideration. The design expressions for both the forces and the moments in the bolted moment connections of both the column bases and the beam-column joints shown in Figure 11.14 are given in Figure 11.15.

For connected sections subject to both bending and shear, the following equations shall be

satisfied:

a) Shear resistance

$$v_U = \frac{V_U}{V_{c,U}} \leq 1.0 ; \quad v_L = \frac{V_L}{V_{c,L}} \leq 1.0 \quad (11.91a \text{ \& } 11.91b)$$

b) Moment resistance

$$m_U = \frac{M_U}{M_{c,U}} \leq 1.0 ; \quad m_L = \frac{M_L}{M_{c,L}} \leq 1.0 \quad (11.92a \text{ \& } 11.92b)$$

c) Combined bending and shear

$$1.25 v_U^2 + 1.25 m_U^2 \leq 1.0 \quad (11.93a)$$

$$1.25 v_L^2 + 1.25 m_L^2 \leq 1.0 \quad (11.93b)$$

where

- v_U, v_L are the shear force ratios at the upper and the lower levels of the critical cross-section respectively ;
- m_U, m_L are the moment ratios at the upper and the lower levels of the critical cross-section respectively ;
- $V_{c,U}, V_{c,L}$ are the design shear capacities at the upper and the lower levels of the critical cross-section respectively; and
- $M_{c,U}, M_{c,L}$ are the design moment capacities at the upper and the lower levels of the critical cross-section respectively.

It should be noted that as the C sections below the critical cross-section are firmly attached to the webs of the gusset plate through bolts, local buckling is unlikely to occur, and hence, $V_{c,L}$ shall be taken as the plastic shear capacity of the C section while $M_{c,L}$ shall be taken as the moment capacity of the gross cross sections. Moreover, the restraining effect due to the presence of the gusset plate on shear buckling of the connected sections above the critical cross-section shall be allowed for.

The presence of bolt holes in the cross-sections shall be allowed for during the determination of both the shear and the moment resistances.

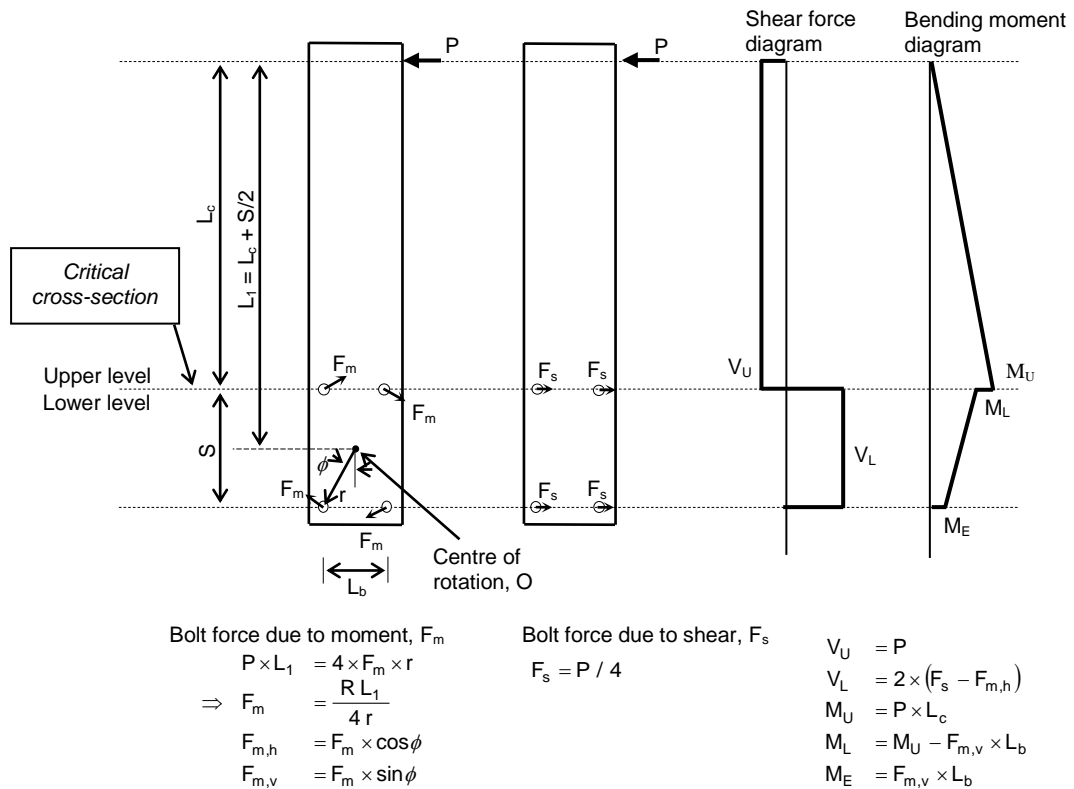

Figure 11.15 - Internal forces of a bolted moment connection

11.7 DESIGN FOR HOLLOW SECTIONS

11.7.1 General design for hollow sections

Clause 11.7 gives recommendations for the design of cold-formed steel hollow sections with nominal thickness up to 22 mm.

Design recommendations: Primary structural members in trusses and portal frames of modest span.

11.7.2 Material Properties

The physical properties of cold-formed hollow steel are given in clause 3.1.6.

The design thickness of the material shall be taken as the nominal thickness.

11.7.3 Mechanical properties

Cold forming is a process whereby the main forming of metal section is done at ambient temperature. It changes the material properties of steel and impairs ductility as well as toughness but enhances strength. The extent to which the properties are changed depends upon the type of steel, the forming temperature and the degree of deformation. Accounting for the changes in material properties, welding requirements as stipulated in clause 11.7.5 shall be followed.

The basic requirements on strength and ductility are given in clause 3.1.2. As a conservative design, no strength enhancement in round corners due to cold-forming is allowed.

To ensure sufficient notch toughness, the minimum average Charpy V-notch impact test energy at the required design temperature should be in accordance with clause 3.2.

11.7.4 Control of external corner profile

In order to prevent corner bend cracking, control of dimensions of external corner profile should conform to the minimum requirements as stipulated in Table 11.4.

Table 11.4 External corner profile

Thickness t (mm)	External corner profile C_1 , C_2 or R_{ext}
$t \leq 6$	$1.6 t$ to $2.4 t$
$6 < t \leq 10$	$2.0 t$ to $3.0 t$
$10 < t$	$2.4 t$ to $3.6 t$

N.B.: The sides need not be tangential to the corner arcs.

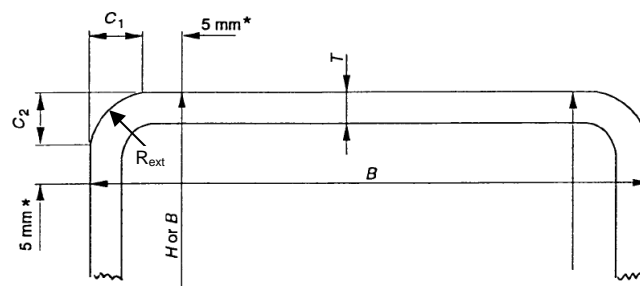

* This dimension is a maximum when measuring B or H and a minimum when measuring T

11.7.5 Welding at cold-formed zones

Welding may be carried out in the corners and the adjacent cold-formed zones, provided that one of the following conditions is satisfied:

- (a) the internal radius-to-thickness r/t ratio satisfies the relevant value given in Table 11.5; or

Table 11.5 Conditions for welding cold-formed areas and adjacent materials

Minimum internal radius/thickness (r/t) ratio	Strain due to cold forming (%)	Maximum thickness (mm)		
		Generally		Fully killed Aluminium-killed steel ($AL \geq 0.02\%$)
		Predominantly static loading	Where fatigue predominates	
≥ 3.0	≤ 14	22	12	22
≥ 2.0	≤ 20	12	10	12
≥ 1.5	≤ 25	8	8	10
≥ 1.0	≤ 33	4	4	6

- (b) the welding procedure shall fulfill the Welding Procedure Specification (WPS) as stipulated in clause 14.3.3.

Alternatively, welding may be carried out in the corners and the adjacent cold-formed zones of those cold-formed hollow sections which are produced to those relevant materials specifications of cold-formed hollow sections given in Annex A1.1.

11.7.6 Cold formed section properties under loading

In general, cold-formed hollow sections may be manufactured by forming of the metal at ambient temperature followed by longitudinal weld or spiral weld. The design of bending moment and shear for cold-formed hollow section of this thickness range subjected to various modes of loading may follow the design provisions stipulated in Section 8. For assessing the compressive strength p_c of cold-formed hollow sections, the curve c as stipulated in Table 8.7 of Section 8 may be used.

11.7.7 Calculation of deflection

General

Deflections should be calculated using elastic analysis. Due allowance shall be made for the effects of non-uniform loading.

11.7.8 Connections

Design recommendations on connections and fastenings with the bolt and screw should refer to Section 9.

11.8 DESIGN FOR COLD-FORMED SHEET PILE SECTIONS

11.8.1 General design for sheet pile sections

This section gives recommendations for the design of cold-formed sheet pile sections with nominal thickness up to 16 mm.

Design recommendations: Steel sheet piling is designed as vertical retaining elements in excavation and lateral support works.

11.8.2 Material properties

The physical properties of cold-formed sheet pile sections are given in clause 3.1.6.

The design thickness of the material shall be taken as the nominal thickness.

11.8.3 Mechanical properties

Cold-forming is a process whereby the main forming of metal section is done at ambient temperature. It alters the material properties of steel and impairs ductility as well as toughness but enhances strength. These changes may limit the ability to weld in cold-formed areas. Welding is occasionally carried out at the edges rather than the bent corners of the steel sheet piles.

The requirements of cold-formed non-alloy and alloy sheet pile steel produced from hot rolled strip or sheet with a thickness equal to or greater than 2 mm in respect of chemical composition, mechanical and technological properties and delivery conditions are stipulated in BS EN 10249, BS EN 10149-1 or equivalent standard.

The material specifications of common hot rolled strip or sheet used for cold-forming are:

- i) S275JRC / S355J0C stipulated in BS EN 10025-2;
- ii) S315MC / S355MC stipulated in BS EN 10149-2; and
- iii) S260NC / S315NC / S355NC stipulated in BS EN 10149-3 respectively.

The strip thickness ranges from 1.5 mm to 16 mm for steel, which has a specified minimum yield strength of 260 N/mm² up to and including 355 N/mm². The available steel grades of alloy quality steels are given in Tables 11.6 and 11.7.

As a conservative design, no strength enhancement is allowed at the cold-formed zones.

To ensure sufficient notch toughness, the minimum average Charpy V-notch impact test energy at the required design temperature should be in accordance with clause 3.2.

11.8.4 Minimum inside radii for cold-formed sheet piles

When cold-formed sheet pile profile is manufactured using JC steel grade, the nominal thickness is limited to 8 mm and the minimum inside radii should conform to Table 11.6 below.

Table 11.6 Minimum inside radii for JC steel grade

Grade designation	Minimum inside radii for nominal thickness (<i>t</i>) in mm		
	$t \leq 4$	$4 < t \leq 6$	$6 < t \leq 8$
S275JRC	1.0 <i>t</i>	1.0 <i>t</i>	1.5 <i>t</i>
S355J0C	1.0 <i>t</i>	1.5 <i>t</i>	1.5 <i>t</i>

Note:

The above minimum inside radii shall apply to JC steel grade only. For tolerances on shape and dimensions, they are specified in BS EN 10249-2 or equivalent standard or equivalent standard. The inside radius to thickness ratio at bent corner of the interlocking crimped end should be limited to 1.5.

When cold-formed sheet pile profile is manufactured using MC or NC steel grade, the nominal thickness can be limited to 16 mm and the minimum internal radii should conform to Table 11.7 below.

Table 11.7 Minimum inside radii for MC / NC steel grades

Grade designation	Minimum inside radii for nominal thickness (t) in mm		
	$t \leq 3$	$3 < t \leq 6$	$6 < t$
S315MC	$0.25 t$	$0.5 t$	$1.0 t$
S355MC	$0.25 t$	$0.5 t$	$1.0 t$
S260NC	$0.25 t$	$0.5 t$	$1.0 t$
S315NC	$0.25 t$	$0.5 t$	$1.0 t$
S355NC	$0.25 t$	$0.5 t$	$1.0 t$

Note:

The above minimum inside radii shall apply to MC/NC steel grades only. For tolerances on shape and dimensions, they are specified in BS EN 10249-2 or equivalent standard. The inside radius to thickness ratio at bent corner of the interlocking crimped end should be limited to 1.0.

11.8.5 Welding at cold-formed zones of cold-formed sheet piles

Welding may be carried out within a length $5t$ either side of a cold-formed area, provided that one of the following conditions as given in clause 11.7.5 is satisfied.

11.8.6 Cold-formed section properties under loading

In general, cold-formed sheet pile sections may be manufactured by forming of the metal at ambient temperature. The design of bending moment and shear for cold-formed sheet pile section of this thickness range subjected to various modes of loading may follow the design provisions stipulated in this Code.

11.8.7 Calculation of deflection

Deflections should be calculated using elastic analysis. Due allowance shall be made for the effects of non-uniform loading.

12 FIRE RESISTANT DESIGN

12.1 DESIGN PRINCIPLES

This section aims to provide guidance on fire resistant design in steel and composite structures which deals primarily with minimising the risk of structural collapse and restricting the spread of fire through the structure.

The fire resistant design method is applicable to steel and composite structures with the following materials:

Structural steel:	Hot rolled steel sections with design strengths equal to or less than 460 N/mm ² .
	Cold formed steel sections with design strengths equal to or less than 550 N/mm ² .
Concrete:	Normal weight concrete with cube strengths equal to or less than 60 N/mm ² .
Reinforcement:	Cold worked reinforcing bars with design strengths equal to or less than 500 N/mm ² .

For steel materials other than those listed above, refer to specialist design recommendations. Alternatively, passive fire protection method should be adopted.

12.1.1 Basic requirements of fire resistance for a structure

a) Mechanical resistance

All structural members in a structure shall be designed and constructed in such a way that integrity failure of the structure does not occur and their load bearing capacities are maintained at the end of the specified fire resistance period.

b) Compartmentation

All those members of a structure forming the boundaries of a fire compartment, including joints, shall be designed and constructed in such a way that they maintain their separating function during the specified fire resistance period, i.e. no integrity nor insulation failure shall occur.

Whenever a fire test is carried out, the fabrication and interface details should follow the details to be used on site as fire testing is essentially a system integrity test.

12.1.2 Fire exposure

The fire exposure to a structure may be based on either of the following two types:

a) Standard fire

The standard fire is a controlled fire exposure described by a standard time - temperature curve as follows:

$$T = 345 \log_{10}(8t + 1) + 20 \quad (12.1)$$

where

T = design fire temperature (°C)

t = elapsed time (minutes)

The required fire resistance periods (FRP) shall be established according to the requirements as stipulated in the current Code of Practice for Fire Resisting Construction.

b) Natural fire

A natural fire refers to a fire exposure that builds up and decays in accordance with the mass and energy balance within a compartment. The quantification of a natural fire shall be performed according to established methods, taking into consideration of uncertainties and risks.

12.1.3 Fire limit states

The structural effects of a fire in a building, or part of a building, shall be considered as a fire limit state, and a fire limit state shall be treated as an accidental limit state. At the fire limit state, a structure shall maintain the integrity of fire resistant compartments for the specified fire resistance period under the entire period of a standard or a natural fire. This shall be achieved by ensuring that

- all structural members in the structure can maintain their load carrying capacities, or
- the loss of load carrying capacity of any member does not cause integrity failure of the fire resistant compartmentation.

Whenever the load carrying capacity of a structural member is demonstrated to be sufficient through the use of advanced methods involving large deformations, it is necessary to ensure that there is no integrity failure at junctions of different structural members caused by these large deformations. Moreover, requirements for insulation and integrity of compartment walls and floors, including any incorporated members, shall also be satisfied.

The fire performance of structural members or a structure shall be determined either through standard fire tests on loaded members or through fire resistant design based on established design methods.

Whenever fire protection materials are required to achieve the specified fire resistance period, the thicknesses of the fire protection materials should be derived from standard fire tests at accredited laboratories whilst the recommendations should be prepared by a suitably qualified person. Alternatively, current assessment methods include (a) standard fire tests, (b) limiting temperature methods, (c) performance-based design methods, and (d) simplified calculation methods.

Connection plates, stiffeners and similar elements should be ordinarily treated with the same fire protection thickness as the primary steel member to which they are attached.

Bracing members required to ensure stability to a structure at the fire limit state shall remain functional during the specified fire exposure, unless alternative load paths can be identified in the structure. Whenever practicable, bracing members should be built into other fire resisting components of the building, such that the bracing members need no additional protection.

12.1.4 Physical and mechanical properties at elevated temperatures

Table 12.1 summarizes all the physical properties of steel and concrete at elevated temperatures for simplified thermal calculations.

Data on the strength reduction factors of hot rolled and cold formed steel, normal weight concrete, and cold worked reinforcing bars at elevated temperatures shall be obtained from Table 12.2. Appropriate level of strains shall be adopted for various types of construction.

For bolts and welds, the strength reduction factors shall be taken from Table 12.3.

Strength reduction factors are used for checking load carrying capacities of structures under different loading and temperature conditions, with or without uses of fire protection materials for various degrees of insulation against outside temperature.

**Table 12.1 - Typical physical properties of steel and concrete at elevated temperatures
(for simplified thermal calculations)**

Property	Steel	Normal Weight Concrete
Density (kg/m ³)	7850	2300
Specific heat (J/kg °C)	600	1000
Thermal conductivity (W/m °C)	45	1.6
Coefficient of expansion (x 10 ⁻⁶)	14	18
Poisson's ratio	0.3	0.2

Table 12.2a - Strength reduction factors for hot rolled steels at elevated temperatures

Temperature (°C)	Strength reduction factors		
	0.5 % strain	1.5 % strain	2.0 % strain
20 °C	1.00	1.00	1.00
100 °C	1.00	1.00	1.00
200 °C	0.92	1.00	1.00
300 °C	0.84	0.99	1.00
400 °C	0.76	0.98	1.00
500 °C	0.61	0.76	0.78
600 °C	0.35	0.46	0.47
700 °C	0.17	0.23	0.23
800 °C	0.09	0.11	0.11
900 °C	0.06	0.06	0.06
1000 °C	0.04	0.04	0.04
1100 °C	0.02	0.02	0.02
1200 °C	0.00	0.00	0.00

Table 12.2b - Strength reduction factors for cold-formed steels at elevated temperatures

Temperature (°C)	Strength reduction factors
20 °C	1.00
100 °C	1.00
200 °C	0.89
300 °C	0.78
400 °C	0.65
500 °C	0.53
600 °C	0.30
700 °C	0.13
800 °C	0.07
900 °C	0.05
1000 °C	0.03
1100 °C	0.02
1200 °C	0.00

Note: In the absence of any other information, Table 12.2b may be adopted for cold-formed structural hollow sections.

Table 12.2c - Strength reduction factors for normal weight concrete at elevated temperatures

Temperature (°C)	Strength reduction factors
20 °C	1.00
100 °C	1.00
200 °C	0.95
300 °C	0.85
400 °C	0.75
500 °C	0.60
600 °C	0.45
700 °C	0.30
800 °C	0.15
900 °C	0.08
1000 °C	0.04
1100 °C	0.01
1200 °C	0.00

Table 12.2d - Strength reduction factors for cold worked reinforcing bars at elevated temperatures

Temperature (°C)	Strength reduction factors
20 °C	1.00
100 °C	1.00
200 °C	1.00
300 °C	1.00
400 °C	0.94
500 °C	0.67
600 °C	0.40
700 °C	0.12
800 °C	0.11
900 °C	0.08
1000 °C	0.05
1100 °C	0.03
1200 °C	0.00

Table 12.2e - Strength reduction factors for hot rolled reinforcing bars at elevated temperatures

Temperature (°C)	Strength reduction factors
20 °C	1.00
100 °C	1.00
200 °C	1.00
300 °C	1.00
400 °C	1.00
500 °C	0.78
600 °C	0.47
700 °C	0.23
800 °C	0.11
900 °C	0.06
1000 °C	0.04
1100 °C	0.02
1200 °C	0.00

**Table 12.3 - Strength reduction factors for bolts and welds
at elevated temperatures**

Temperature (°C)	Strength reduction factors for bolts	Strength reduction factors for welds
20 °C	1.00	1.00
100 °C	0.97	1.00
150 °C	0.95	1.00
200 °C	0.94	1.00
300 °C	0.90	1.00
400 °C	0.78	0.88
500 °C	0.55	0.63
600 °C	0.22	0.38
700 °C	0.10	0.13
800 °C	0.07	0.07
900 °C	0.03	0.02
1000 °C	0.00	0.00

12.1.5 Material factors and load factors

In checking the strength and stability of a structure at the fire limit state, the following material and load factors shall be adopted:

Table 12.4 - Material factors for fire limit state

Material	γ_m
Steel	1.00
Concrete	1.10
Reinforcement	1.00

Table 12.5 - Load factors for fire limit state

Loads	γ_f
Dead load	1.00
Imposed loads:	
a) permanent:	
1) those specifically allowed for in design, e.g. plant, machinery and fixed partitions	1.00
2) in storage buildings or areas used for storage in other buildings (including libraries and designated filing areas)	1.00
b) non-permanent:	
1) in escape stairs and lobbies	1.00
2) all other areas (imposed snow loads on roofs may be ignored)	*0.80
Wind loads	0.33

Note: * The value may be reduced to 0.50 when suitable justification is available.

Whenever appropriate, the effect of wind load should be considered in checking primary members of a structure. However, there is no need to check for secondary members of the structure under the effect of wind load except in very special circumstances.

12.2 FIRE RESISTANCE DERIVED FROM STANDARD FIRE TESTS

In general, it is considered that all the construction elements specified in the Code of Practice for Fire Resisting Construction are considered as satisfying the specified fire resistance periods. For other construction elements and structural members, they should be tested in accordance with appropriate fire testing requirements to verify their fire resistance periods.

12.2.1 Fire resistances of structural members

The fire resistances of structural members shall be established by:

- a test report indicating that the construction elements or the structural members are capable of resisting the action of fire for the specified period. The test should be carried out and the test report prepared and endorsed by a HOKLAS accredited laboratory or other accredited laboratory which has mutual recognition agreements / arrangements with the HOKLAS or the BA; or
- when the complexity and scale of fire testing is not practical, an assessment report against established standard fire testing that the construction elements and the structural members are capable of resisting the action of fire for the specified period. The assessment should be carried out and the assessment report prepared and endorsed by:
 - i) a HOKLAS accredited laboratory or other accredited laboratory which has mutual recognition agreements / arrangements with the HOKLAS or the BA; or
 - ii) an establishment or a professional having the appropriate qualifications and experience in fire resisting construction recognized by the BA.

The loads applied in these fire tests shall correspond to the design factored loads at the fire limit state. Where the design factored loads for the fire limit state differ from those applied in the tests, the test results should be adjusted according to established design recommendations. These tests shall be carried out at accredited laboratories whilst the recommendations derived from them shall be prepared by a suitably qualified person. For details, refer to the Code of Practice for Fire Resisting Construction 1996.

12.2.2 Failure criteria for standard fire tests

The fire resistance of a structural member shall be determined with respect to load-bearing capacity, integrity and insulation as follows:

12.2.2.1 Load-bearing capacity

The test specimen shall be considered to have failed in load-bearing capacity if it is no longer able to support the test load. This shall be taken as either of the following, whichever is exceeded first:

a) For flexural members:

(i) Deflection limit = $\frac{L^2}{400 d}$ (in mm); and (12.2a)

(ii) Rate of deflection = $\frac{L^2}{9000 d}$ (in mm/min) when a deflection of $L/30$ has been exceeded. (12.2b)

where L is the clear span of specimen (in mm); and

d is the section depth of the structural member (in mm).

b) For axially loaded compression members:

(i) Axial shortening limit = $\frac{h}{100}$ (in mm); and (12.3a)

(ii) Rate of shortening = $\frac{3h}{1000}$ (in mm/min) (12.3b)

where h is the initial height (in mm).

12.2.2.2 Integrity

The test specimen shall be considered to have failed in integrity when any one of the following occurs:

- collapse,
- sustained flaming on the unexposed face lasting more than 10 seconds,
- ignition of a cotton pad, or
- opening of an excessive gap.

12.2.2.3 Insulation

The test specimen shall be considered to have failed in insulation when one of the following occurs:

- a) if the mean unexposed face temperature increases by more than 140°C above its initial value; or
- b) if the temperature recorded at any position on the unexposed face is in excess of 180°C above the initial mean unexposed face temperature.

12.3 FIRE RESISTANCE DERIVED FROM LIMITING TEMPERATURE METHOD

- a) This method is applicable to the determination of the fire resistance of steel members such as tension members, columns and beams.

No protection is needed when the design temperature does not exceed the limiting temperature under a specific load ratio where:

- the load ratio is defined as the load applied at the fire limit state divided by the load causing the members to fail under normal conditions, and
- the limiting temperature of a structural member is defined at the temperature at which it will fail.

- b) Limiting temperatures of critical elements in various structural members under different load ratios shall be obtained from established recommendations.

For information, the section factor, H_p / A , is defined as the ratio of the surface perimeter exposed to radiation and convection, H_p , to the cross-sectional area, A .

12.4 FIRE RESISTANCE DERIVED FROM PERFORMANCE-BASED DESIGN METHODS

12.4.1 Basis of analysis

- a) Based on fundamental physical behaviour of materials and behaviour of structural elements and systems, performance-based design methods provide realistic assessment of structures under fire, i.e. a reliable approximation of the expected structural behaviour of relevant individual members, subassemblies or entire structures at specific fire resistance periods. Generally, it consists of two separate calculation models for the determination of:
 - (i) Thermal response
The development and distribution of the temperature within structural elements.
 - (ii) Mechanical response
The mechanical behaviour of the structure or of any part of it.

Caution should be taken for any potential failure modes which have not been covered by the performance-based design methods, for example, local buckling, insufficient rotation capacity, spalling and failure in shear. Appropriate means such as steel constructional details should be provided to ensure that such failure modes do not control in reality.

12.4.2 Thermal response

- a) The thermal response model shall be based on established principles and assumptions of the theory of heat transfer, and the temperatures shall be evaluated according to established calculation procedures.
- b) The thermal response model shall consider
 - (i) the relevant fire exposure in the structure;
 - (ii) the variation of the thermal properties of structural elements and relevant fire protective materials within the temperature ranges considered; and
 - (iii) appropriate boundary conditions.
- c) The effects of non-uniform thermal exposure and of heat transfer to adjacent building components shall also be incorporated wherever appropriate.
- d) The effects of active protective measures, such as detection or sprinkler system, may be included wherever appropriate.
- e) For simplicity, the influences of moisture content and migration within concrete and fire protection materials may be conservatively neglected.

12.4.3 Mechanical response

- a) The mechanical response model shall be based on established principles and assumptions of the theory of structural mechanics, taking into account the effects of temperature. It should incorporate:
 - (i) the combined effects of mechanical actions, geometrical non-linear effects, geometrical imperfections and thermal actions;
 - (ii) the stress-strain curves at elevated temperatures;
 - (iii) the effects of non-linear material properties, including the effects of unloading on the structural stiffness; and
 - (iv) the effects of thermally induced strains and stresses, both due to temperature rises and differentials.
- b) The deformations at fire limit state should not be excessive in order to maintain integrity and compatibility between all parts of the structure. However, the effects of high temperature creep may not be considered explicitly.

12.4.4 Validation of performance-based design methods

- a) The calculation results shall be verified against relevant test results in terms of deformations, temperatures and fire resistance periods.
- b) A sensitivity analysis on the calculation results shall be carried out against all critical parameters required in the verification such as the buckling length, the size of the elements, the load level and etc., in order to ensure that the model complies with sound engineering principles.

12.4.5 Simplified calculation methods

- a) For structural adequacy, the moment capacity of a beam member such as a steel beam, a composite beam, or a composite slab with profiled steel decking at elevated temperatures should be greater than the applied moment in fire.
- b) The moment capacity of the beam member should be evaluated according to rectangular stress blocks comprising the reduced strength of various elements of the member at elevated temperatures.
- c) Material properties, reduction factors for various materials at elevated temperatures, and load factors in fire limit state given in Tables 12.1, 12.2, 12.3, 12.4 and 12.5 should be adopted.
- d) For other types of structures, such as external structures exposed to external fire exposure, water-filled tubes and portal frames, established design methods should be followed.
- e) If fire protection is specified in any of the connecting members, the same protection system should be provided to the connection regions.

12.5 PERFORMANCE REQUIREMENTS

Structural members and systems should be designed to resist external loads under fire exposure with partial load factors for extreme events obtained from Table 4.3. Deformation should be limited to the following limits: -

i) for flexural members, deflection limit = $\frac{L^2}{400 d}$

ii) for axially loaded members, deflection limit = $\frac{h}{100}$

where L is the clear span of specimen (in mm);

d is the section depth of the structural member (in mm); and

h is the initial height (in mm).

Advanced analysis allowing for thermal and mechanical properties of structural elements under fire exposure should be carried out to demonstrate the stability and integrity of structural element under fire exposure. The advanced analysis should follow the requirements as stipulated in section 6.9 with allowance for geometric imperfections and material non-linear effects. Degradation of strength and stiffness of the structural systems at elevated temperature, with or without fire protection, should be allowed for in the advanced analysis.

13 PERFORMANCE-BASED DESIGN GUIDANCE FOR PARTICULAR TYPES OF STRUCTURES, INCLUDING GUIDANCE ON GENERAL MAINTENANCE OF STEEL STRUCTURES

13.1 HIGH-RISE BUILDINGS

13.1.1 Structural systems for high-rise buildings

This clause mainly focuses on commonly used structural systems in Hong Kong. However, consideration should be given to other structural systems. The principal structural systems for high-rise steel and steel composite buildings in Hong Kong and similar region are:

- (a) Steel perimeter columns, floor beams acting compositely with concrete floor and a concrete core providing lateral stability.
- (b) Steel perimeter moment frames providing lateral stability, steel and concrete composite floor and concrete core.
- (c) Tube in tube systems which are a development of perimeter tube systems.
- (d) Outrigger systems comprising a concrete core with a limited number of large perimeter mega columns of composite steel and concrete construction.
- (e) External mega trusses or space frames providing the most efficient structural system for super high-rise buildings.
- (f) Giant portal frame systems (mega frames) providing lateral stability.

13.1.2 Stability issues for high-rise buildings

13.1.2.1 Overall rigid body stability

Large lateral loads exist on high-rise buildings in a typhoon wind climate. Such buildings should be checked for stability against overall overturning under the Building (Construction) Regulations. Possible uplift or tension between superstructure elements, e.g. columns or core, and pile caps or between pile caps and piles, should be taken into account in the design.

13.1.2.2 Second-order effects

Second-order $P-\Delta$ and $P-\delta$ effects could be significant for high-rise buildings and should be evaluated and allowed for. They can be considered directly by a second-order analysis using the $P-\Delta-\delta$ analysis in section 6.

Alternatively, the $P-\Delta$ effect should be allowed for by amplifying the moment using equation 6.9 in section 6. The $P-\delta$ effect should be considered by the effective length method using the non-sway column buckling length or conservatively assuming the column length as the effective length.

13.1.3 Considerations for particular details

13.1.3.1 Outrigger system

Differential shortening between core and perimeter columns can occur in outrigger or other structural systems. Typically the columns will be highly stressed as compared with the core. Thus the columns will shorten more than the core as gravity loads build up during construction. In addition, concrete elements will continue to creep under load after construction is completed.

Large forces may be induced in the columns and outrigger beams by differential shortening. These should be estimated by carrying out a gravity load analysis and allowed for in the design of the columns and outrigger beams by taken into account the construction sequence. Both elastic and long-term differential shortening caused by creep shall be considered.

Means of adjustment such as a system of jacks and wedges may be provided in order to reduce the magnitude of these forces. The Responsible Engineer shall decide at which

stage in the construction process the outrigger shall be locked to the column and then design the permanent structure to safely resist the further forces which arise.

13.1.3.2 *Tolerance for lift cores*

High-rise buildings may require more stringent specifications on the allowable deviation of lift cores, because of the likelihood of high-speed lifts being used. Non-structural elements such as pipes, claddings, curtain wall, windows etc. should also be checked against sway.

13.1.3.3 *Connection ductility in composite frames*

Sufficient ductility to allow rotation without brittle failure in extreme events should be provided in composite frame connections.

13.1.3.4 *Connection of steel floor beams to concrete cores*

Connections between steel floor beams and concrete cores should provide tolerance for erection and sufficient tie capacity for robustness. As a minimum, the tying force should be taken from clause 2.3.4.3 for internal ties, i.e. a value of:-

$$0.5 \times (1.4G_k + 1.6Q_k) \times \text{tie spacing} \times \text{tie span}$$

but not less than 75 kN. The connection detail should be ductile, i.e. allow significant rotation such that the connection can function after the beam sags into a catenary tie. Steel connections from beams to core shall be fire protected even when a fire engineering approach has justified that the floor beams themselves do not require any fire protection.

13.1.4 Considerations for design against extreme events

13.1.4.1 *Robustness*

A structure should be designed for adequate robustness. Clause 2.3.4 provides guidance on structural integrity, design against progressive collapse and design of key elements.

13.1.4.2 *Tying of very large columns*

High-rise buildings with outrigger systems or external truss systems often have very large perimeter columns or mega columns. The lateral stability and tying in of such columns requires special consideration as the restraint forces can be large. In accordance with clause 2.3.4.3(c) the restraint force should be 1% of the maximum factored dead and imposed loads in the column. As an alternative an appropriate non-linear buckling analysis may be carried out to evaluate the restraint forces required. This analysis may justify a higher or a lower restraint force than the 1% value.

The vertical tension capacity of such columns should be considered such that the structure as a whole could survive the removal of a section of mega column.

13.1.4.3 *Structural considerations for escape routes*

Elements such as escape staircases, refuge floors, evacuation lift shafts and the like are required to function for as long as necessary to allow people to leave the building safely should an extreme event occur. This requirement shall be taken into account in the structural design of such elements.

13.1.5 Wind engineering for high-rise buildings

For guidance and requirements on lateral deflections and accelerations of high-rise buildings, refer to clause 5.3.

13.1.5.1 *General*

Effects of wind on buildings should be considered in structural, foundation and cladding design and should not adversely affect comfort of occupants and pedestrians. Control of deflection and acceleration should follow clause 5.3.4. Vortex shedding and cross-wind response should be considered, especially in the design of slender structures. The damping effect may be considered for evaluation of actual structural response.

13.1.5.2 *Wind tunnel test*

It is recommended that a wind tunnel test be carried out to study the behaviour of structures of non-conventional forms and in locations where complicated local topography may adversely affect the wind condition. Where particular adjoining or surrounding

buildings could significantly influence the local wind profile, the effects of their probable removal should be considered.

13.1.5.3 *Vibration*

Structures should be designed to perform satisfactorily against vibration in ultimate (resonance) and serviceability (annoyance and local damage) limit states. Vibration control of high-rise buildings can be considered under two aspects: deflection and acceleration.

13.1.5.4 *Deflection*

Deflections in a high-rise building should generally satisfy the following requirements, unless their violation can be justified as tolerable.

- (1) The deflection under serviceability loads of a high-rise steel and steel-composite building or part should not impair the strength or efficiency of the structure or its components or cause damage to the finishes.
- (2) Generally, the serviceability loads should be taken as the unfactored specified values.
- (3) When checking for deflections, the most adverse realistic combination and arrangement of serviceability loads should be assumed, and the structure may be assumed to behave elastically.
- (4) Suggested limits for the calculated deflections of certain structural members or a building as a whole are given in Table 5.1. Circumstances may arise where greater or lesser values would be more appropriate. In such circumstance, justification to prove its structural suitability is required.
- (5) In locations where buildings are close together, the possibility of pounding should be investigated.

13.1.5.5 *Acceleration*

Human response to building motions is a complex phenomenon involving many physiological and psychological factors. Human comfort is generally considered as more measurable by acceleration than other quantities. For high-rise buildings, the highest magnitudes of acceleration generally occur near the top of the building at its first natural frequency, but unacceptable accelerations may occur elsewhere in such buildings and in vibration modes with higher frequencies. Refer also to clause 5.3.4.

13.2 **GUIDANCE ON DESIGN OF TRANSMISSION TOWERS, MASTS AND CHIMNEYS**

13.2.1 **Structural systems for transmission towers, masts and chimneys**

The steelwork for the structures of towers, masts and steel chimneys is exposed and needs a high level of corrosion protection due to difficulties of access.

The primary structural systems for masts and towers typically include the following:

- (a) Lattice frames
- (b) Steel tubes
- (c) Cables supporting lattice or tubular masts

Appearance may be highly important in some locations.

Structural weight, buckling stability, method of construction and effects of wind and ice load are key design issues.

Fatigue may need to be considered.

13.2.2 **Overall stability of towers, masts and chimneys**

Such structures have little redundancy of load path. Failure of single elements is likely to result in collapse. Typically loading from a number of wind directions needs to be considered. The following stability checks should be made:

- (a) Overall system overturning.
- (b) Overall system buckling.
- (c) Local system buckling.
- (d) Strength of all members and connections.
- (e) System imperfections and lack of fit.

13.2.3 Particular details

Particular details requiring special consideration for such structures are:

- (a) Mast bases and anchor blocks.
- (b) Cable fixings to mast and to anchor blocks.
- (c) Welded connection details with regard to fatigue.
- (d) Welded joint detailing to avoid cracking during galvanising or other fabrication and erection processes.

13.2.4 Considerations for design against extreme events

- (a) Sabotage, especially in view of the minimal structural redundancy. It is often necessary to fence around access points. Other security protection may be desirable depending on the likely wider consequences of a failure.
- (b) Remoteness. Access difficulties can delay inspection and repair of damage.
- (c) Hilltop sites increase exposure to wind and other adverse weather events.
- (d) In colder regions, ice can build up on lattice elements and cables leading to greatly increased wind and gravity loads.
- (e) Aircraft warning painting and/or lighting is likely to be required on many sites.

13.2.5 Serviceability issues

The following serviceability issues shall be addressed for towers and masts:

- (a) Wind induced vibrations of antennas, structural elements and cables.
- (b) Access for maintenance of steelwork can be very difficult, therefore a high quality protective system should be specified.
- (c) Required stiffness for purpose (e.g. microwave alignment).
- (d) Access facilities for routine maintenance and inspection shall be designed to take into account of the availability and likely competence of staff trained to climb such structures but should normally include ladders fitted with a fall arrest system and regular platforms to rest and safely place work equipment.

13.2.6 Design issues for steel chimneys

In addition to the guidance given in clauses 13.2.1 to 13.2.5, special attention should be given to the following in the design of steel chimneys and flues:

- (a) Wind-excited vibrations should be considered and analyzed by aerodynamic methods. For circular chimneys the simplified method in clause 13.2.8 may be used.
- (b) Design should be in accordance with the appropriate provisions of the Code and in the acceptable references in Annex A2.1.
- (c) To control buckling in the case of a thin walled chimney with effective height to diameter ratio of less than 21 and diameter to thickness ratio of less than 130, the ultimate compressive stresses in the chimney structure arising from the three principal load combinations shall be limited to a value calculated in accordance with Table 12.2 of clause 12.1.4 which allows for reduced steel strength at elevated temperatures. If this value exceeds 140 N/mm², then a value of 140 N/mm² shall be used. The value should be reduced further for higher aspect ratios.

- (d) Where the temperature is higher than 315°C, a strength reduction factor calculated in accordance with Table 12.2 of clause 12.1.4 should be applied to the design strength in the steel.
- (e) Guy cables used as anchorage to a chimney should be positioned at a minimum distance of 3 m below the outlet of the chimney to avoid corrosion from flue gases. These guys should not be considered for strength or stability because of the practical problems of examination and maintenance.
- (f) Brackets providing resistance to lateral displacement of the chimney and/or supporting part or all of the weight of the chimney should be positioned at distances not exceeding 6 m apart.

13.2.7 Construction and corrosion protection of steel chimneys

General guidance on corrosion protection is given in clause 5.5. For construction and corrosion protection of chimneys and flues, the relevant parts of acceptable references in Annex A2.1 should be followed.

The exterior and interior surfaces of a steel chimney or flue should have satisfactory protective treatment. Allowance for corrosion should be made in the shell in addition to the thickness obtained from calculations for structural stability. Typically an allowance of 3 mm would be required for chimneys externally fitted with waterproof insulation or cladding and internally lined and protected. For unprotected chimneys, 4.5 mm should be provided for a design life of 10 years and 8 mm for 20 years. Unprotected oil-fired steel chimneys are not recommended.

Bimetallic action may adversely affect a chimney or flue, and should be avoided. If two dissimilar metals have to be connected, a suitable non-conductive and water-impervious material should be placed between them.

13.2.8 Wind-excited vibrations of circular chimneys

Flexible slender structures are subject to vibrations caused by cross wind and along wind action. Structures with a circular cross section, such as chimneys, oscillate more strongly across than along wind.

The following simplified approach may be used for across wind vibration, see also clause 5.3:

- (a) The Strouhal critical velocity V_{crit} in metres per second for the chimney is to be determined by:

$$V_{crit} = 5 D_t f \quad (13.1)$$

where f (in Hz) is the natural frequency of the chimney on its foundations. This may be calculated analytically or from the following approximate formula for the case of a regular cone:

$$f = \frac{500(3D_b - D_t) \left[\frac{W_s}{W} \right]^{\frac{1}{2}}}{h^2} \quad (13.2)$$

and

- h is the height of chimney (in m)
- D_t is the diameter at top (in m)
- D_b is the diameter at bottom (in m)
- W is the mass per metre height at top of structural shell including lining or encasing, if any (in kg)
- W_s is the mass per meter height at top of structural shell excluding lining (in kg)

- (b) If V_{crit} exceeds the design wind velocity in metres per second given by the following formula

$$V = 40.4 (q)^{0.5} \quad (13.3)$$

where q is the design wind pressure in kN/m², severe vibration is unlikely and no further calculation is required.

- (c) If V_{crit} is less than the design wind velocity, the tendency to oscillate C may be estimated by the following empirical formula:

$$C = 0.6 + K \left[\frac{10 D_t^2}{W} + \frac{1.5\Delta}{D_t} \right] \quad (13.4)$$

where

Δ is the calculated deflection (in m) at the top of the chimney for unit distributed load of 1 kPa.

K is 3.5 for all welded construction, 3.0 for welded with flanged and bolted joints and 2.5 for bolted and riveted or all riveted.

- (d) If C is less than 1.0, severe vibration is unlikely. If C is between 1.0 and 1.3 the design wind pressure for the chimney should be increased by a factor C^2 . If C is larger than 1.3 stabilizers or dampers should be provided to control the vibrations.

13.3 GLASS AND FAÇADE SUPPORTING STRUCTURES

13.3.1 General

Glass and façade panel supporting structures include curtain wall and structures used in supporting glass wall, skylight, balustrade, canopy etc., which support brittle façade and panels. Special consideration should be given to the design of these supporting structures because of lack of ductility in glass and most façade panel materials. Owing to the limited deflection tolerance of glass and most façade panels, deflection can be both serviceability and ultimate requirements. The buckling strength of some members in trusses not fully restrained along their spans depends sensitively on the effective length which is complex to determine. For design of structures with ultimate strength controlled by buckling, a second-order analysis avoiding the use of effective length assumption should be employed.

13.3.2 Deflection limit

Unless justified by more rigorous calculation to account for the flexibility of supporting members, structural members in support of glass / façade panels should not deflect more than 1/180 of their spans in order to validate the rigid support assumption in glass or cladding panel design.

13.3.3 Requirements

The general requirements for design of glass supporting structures are as follows:

- (1) The structures should satisfy general design rules in other sections of the Code.
- (2) Elastic design method should be used. Supporting structures should remain elastic under ultimate factored loads.
- (3) It should have sufficient deformation capacity to accommodate the movements of main structures and to avoid excessive displacement in panels.
- (4) Deflection, strength and stability should be checked under combinations of dead load, imposed load, wind load, temperature and movement of main structure due to loads and creep.

- (5) The main supporting members and structures may be suspended to the main structure. If they are supported on main structure along their span or by rigid connections at both ends, their interaction should be considered.
- (6) Direct contact between steel or metal structures with brittle or delicate cladding materials such as granite, glass and aluminium panels should be avoided. Separation by flexible materials should be detailed.
- (7) Sequential collapse due to failure or breakage of a façade or glass panel should be avoided.

13.3.4 Loadings and actions

13.3.4.1 Load pattern

- (1) Critical arrangements of loads should be considered.
- (2) In the case of wind load applied on un-braced truss, patch loadings with pressure levels of full and half wind load on a single structure or on different spans/bays of a continuous structure should be considered.
- (3) Patterned imposed loads should be considered in the evaluation of maximum induced forces.

13.3.4.2 Loads

The HKWC and Building (Construction) Regulations should be used.

13.3.4.3 Temperature

Temperature load plays a particularly important role in design of glass and façade supporting structures. The temperature range below may be used for local design.

- (1) External ambience temperature should be 0-40°C and internal temperature should be 5-35°C.
- (2) Surface exposed outside and under sunlight should be considered for a temperature of 0-80°C for dark colour and 0-60°C for light colour.
- (3) Surface not exposed outside but under direct sunlight should be considered a temperature range of 10-50°C.
- (4) Surface temperature exposed outside should be 0-50°C for clear glass and 0-90°C for tinted glass.
- (5) The actual temperature changes of a structure should be determined relatively to the temperature when the structure is installed at site. For example, if the temperature during installation is 20°C, the temperature changes will be +30°C and -10°C in accordance with (3) above.

13.3.4.4 Movements

Movement is an important design consideration for glass supporting structures.

- (1) Movements may be one-way like concrete creep, settlement, shrinkage, and may be cyclic due to thermal, moisture, wind loads or imposed loads.
- (2) Horizontal movement can be taken as storey height/300, the allowable deflection of the main structure or the calculated deflection. Their largest value should be used.
- (3) Vertical movement may be determined from the possible relative deflections between the consecutive floors.
- (4) Slot-holes in connections should be designed to prevent loosening by use of locking devices such as locking nuts, locking washers etc.

13.3.5 Tensioning structural systems

In the design of structural systems with tension rods or cables, special attention should be given to their geometrically nonlinear behaviour and their sensitivity to temperature change, support movement and possible creep in the cable itself and in the supporting structures. In addition to conventional consideration of loads, clause 13.3.4 for special load consideration should be referred in design of movement and temperature sensitive

structures. Its effects on supporting structures should be considered. Pre-tensioned forces can be applied to the tension rods or cables by means of jacks, turn-buckles for light-duty system or other means. A proper monitoring system should be adopted to ensure applied pre-tension forces are within tolerance.

- (1) Only the second-order elastic analysis should be used in force and deflection calculations of pre-tensioned members.
- (2) Effects of movement in supporting structures, temperature change and possible creep should be considered for determining the required force under various combined load cases.
- (3) In design of tensioning system, load sequence needs careful consideration and slackening in members may not be allowed for cables but permitted in tension rod, provided that its buckling capacity is not exceeded. No tensile stress should exceed the material design strength.
- (4) Installation procedure and loading sequence should be considered in the design process.
- (5) Combined load cases should include full or 80% pre-tension force whichever the unfavourable.
- (6) Three dimensional modelling may be required to investigate into the interaction between tension system and supporting structure of comparable stiffness. Deflections release pre-tension forces in tension rods or cables and they are absorbed by the flexibilities of the supporting beams and the pre-tensioned truss. When concrete structures are used as supports, the long-term and short-term Young's modulus of elasticity, cross-sectional area and second moment of area of concrete members should be adopted appropriately for long-term and short-term loads.
- (7) For material such as stainless steel without a distinctive yield point, the 0.2% proof stress should be used.
- (8) The thread area of tension rods should be used in the calculation of tensile loads.
- (9) Full-scale test to PNAP APP-37 (formerly known as PNAP 106) should be carried out for the critical load cases which can be simulated in laboratory.

The structural behaviour is sensitive to site boundary condition. The test report should be prepared by a qualified engineer with sound background in structural engineering in order to correctly simulate the complex response of the structure in a HOKLAS accredited laboratory or other accredited laboratory which has mutual recognition agreements / arrangements with the HOKLAS or the BA.

13.4 TEMPORARY WORKS IN CONSTRUCTION

Temporary works, particularly scaffolding, are susceptible to collapse, and particular attention should be paid to their design. Causes of collapse of temporary works are often due to buckling of members, instability in structures due to inadequate bracing, excessive eccentricities, differential settlement, or partial failure of foundations. Connections are often made from poor quality welding, with flame-cut rather than sawn ends in bearing and eccentricities.

13.4.1 Design philosophy

For temporary structure whereby the λ_{cr} is less than 5, the second-order analysis as described in section 6 should be carried out irrespective of its height.

Pre-tensioned steel wire and cable can be used when it is properly anchored to prevent slippage. Minimum thickness of members should be 2.0 mm and protection is required against corrosion. Hoarding is not included in this clause.

13.4.2 Second-order effects

The second-order P-Δ effects in Figures 13.1a & 13.1b and P-δ effect in Figure 13.1c are inherent to all practical structures and they are particularly important for temporary slender structures. In the analysis and design, these effects introduce an additional stress to the cross-section of a member and they are required to be accounted for.

In correspondence to the P-Δ and P-δ effects, the system imperfection as out-of-plumbness and member curvatures should be considered. Further, the clearance at joints between scaffolding units should be simulated in an analysis using a slightly deformed structural geometry or by application of an equivalent notional horizontal force.

13.4.3 Out-of-plumbness

The out-of-plumbness inclination ϕ of temporary structure not higher than 10 m should be taken as 1%, i.e.

$$\phi = 0.01 \quad (13.5)$$

For temporary structures higher than 10m, the out-of-plumbness inclination is given by

$$\phi = \frac{0.1}{H} \quad (13.6)$$

in which H is the height of the temporary structure in metres.

Alternatively, an equivalent notional horizontal force equal to the initial inclination times the applied vertical forces at the point of application of the vertical forces can be applied to simulate out-of-plumbness.

The actual structure on site should be checked not to exceed the specified out-of-plumbness in Equation 13.5 or 13.6.

13.4.4 Fitness tolerance

Sleeve and splice tolerance exists for fitting of scaffolding units. A realistic fitness tolerance off the centre line of the original vertical structure should be assumed in an analysis and tolerance should be referred to clause 13.4.8.

13.4.5 Member imperfections

Member imperfection in columns of temporary structures should be taken as,

$$\delta = \frac{L}{500} \quad (13.7)$$

and this value may be reduced when columns are placed in parallel as,

$$\delta = \frac{L}{500} \cdot \frac{1}{\sqrt{n}} \quad (13.8)$$

where n is the number of structural elements arranged parallel to each other and similarly supported and propped, with their deformations of the same magnitude due to systematic influences can be excluded.

13.4.6 Support settlements and flexible supports

Support settlements and flexible supports generate a load re-distribution process and should be avoided. Strong and rigid supports should be provided. If it is not possible, their effects should be estimated and included in an analysis.

13.4.7 Over-turning

Over-turning should be prevented with a minimum factor of safety of 2.0 under working loads.

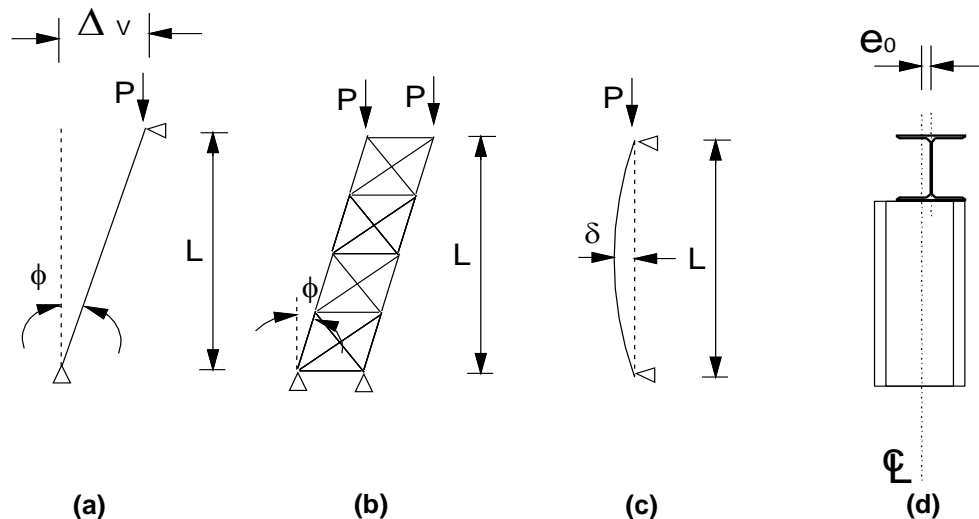

Figure 13.1 - Values of geometric imperfections: (a) & (b) out-of-plumbness, (c) member imperfection and (d) eccentricity

13.4.8 Tolerance and clearance

The following tolerances should be adopted for fabricated temporary structure:

- (1) Inclination of a column from vertical (see Figures 13.1a and 13.1.b)
 - i) for a column or strut of length $L_c < 1450$ mm, Δ_v should not exceed 5 mm;
 - ii) for a column or strut of length $L_c \geq 1450$ mm, Δ_v should not exceed $0.0035L_c$ or 25 mm, whichever is the lesser;

where L_c is the clear height of the column or strut and Δ_v is the inclination from vertical (in mm).
- (2) Out-of-straightness of columns and beams (see Figure 13.1c)
 - i) for a column or strut of length $L < 3350$ mm, δ should not exceed 5 mm;
 - ii) for a column or strut of length $L \geq 3350$ mm, δ should not exceed $0.0015L_c$ or 25 mm, whichever is the lesser;

where L is the clear height of the column or strut and δ is the out-of-straightness of the column or strut (in mm).
 - iii) The same tolerance is required for beams, except that δ should not exceed 40mm when span is larger than 3350mm.
- (3) The eccentricity of any beam e_0 should not exceed 5 mm (see Figure 13.1d).

In circumstances rendering compliance with the above physical tolerances impractical, or unlikely, members should be analysed and designed for such wider tolerance as is considered to be appropriate. Allowable tolerances should be specified on erection/fabrication drawings.

13.4.9 New and used systems

Seriously damaged, cracked, bent or rusted scaffolds should not be used. The condition of the used scaffolds shall be assessed by the Responsible Engineer and only scaffolds of excellent condition can be designed to original design buckling strength.

13.4.10 Module testing

Modular scaffold should be designed and used in accordance with the manufacturer's recommendations. Full justifications including buckling design check by second-order

analysis and further tests may be required for critical scaffold modules not covered by the manufacturer's recommendations.

Module testing for the proprietary scaffolding and temporary structural unit should be carried out for height not previously tested or substantiated in manufacturer's manual in order to confirm the accuracy of computed design resistance.

13.5 LONG SPAN STRUCTURES

13.5.1 Systems for long span structures

Long span structures refer to structures with high span-to-depth ratio commonly used in stadia, roofs over exhibition halls, airports, aircraft hangers and similar buildings providing a large column free space. The steelwork for long span building structures is commonly exposed. Structural weight and buckling stability require special considerations in design. The method and sequence of construction will influence the design and should be properly taken into consideration. The stability of partially completed structure shall be ensured during construction.

13.5.2 Overall stability of long span structures

The following stability checks shall be made for long span steel structural elements:

- (a) Overall system buckling.
- (b) Member buckling.
- (c) Snap through instability.
- (d) System imperfections and lack of fit.
- (e) Stability during construction.

13.5.3 Particular details

Particular details requiring special consideration are:

- (a) Steel masts and their bases.
- (b) Cable fixings.
- (c) Connections of main truss elements.
- (d) Connections of secondary to main trusses to provide restraint against buckling.
- (e) Dimensional tolerance of interconnected components forming a large span.

13.5.4 Considerations for design against extreme events

Crowd barriers must be designed to resist large crowd loads without collapse. Long span roof trusses should be designed as key elements.

13.5.5 Serviceability issues

The following serviceability issues shall be addressed for long span structures:

- (a) Vibration from crowds. Refer to section 5 of the Code.
- (b) Wind induced vibrations of roof elements and cables. Fatigue may need to be checked.
- (c) Access for maintenance of roof steelwork can be very difficult therefore a high quality protective system should be specified for the steelwork.
- (d) Deflection limits for long span trusses under live and wind loads depend on circumstances. A value of span/360 may be used for preliminary design in the absence of other requirements. Significantly smaller deflection limits will be required for applications such as: aircraft hanger doors and stadia opening roofs.

13.6 FOOTBRIDGES

13.6.1 Design philosophy

A footbridge design should satisfactorily accomplish the objectives of constructability, safety and serviceability.

13.6.2 Loads

In general, footbridges are typically designed for pedestrian loads, which are considered static loads. The nominal design load should be obtained from Building (Construction) Regulations and standards issued by the Highways Department. Loads induced by wind, support settlement and temperature change should be accounted for in the design. For local effects, a concentrated load of 10 kN acting on a square of sides of 0.1 m is specified.

13.6.3 Design for strength, deflection and fatigue

13.6.3.1 Strength

Steel structural members, components and connections of a footbridge shall be so proportioned that the basic design requirements for the ultimate limit state given in the Code are satisfied.

13.6.3.2 Deflection

- (a) Structural steel members and components of a footbridge shall be so proportioned that the deflections are within the limits agreed between the client, the designer and related authorities as being appropriate to the intended use of the footbridge and the nature of the materials to be supported.
- (b) The limiting values for vertical deflections given in Table 13.1 are illustrated by reference to the simply supported beam shown in Figure 13.2, in which:

$$\delta_{\max} = \delta_1 + \delta_2 \amalg \delta_0 \quad (13.9)$$

where δ_{\max} = the sagging in the final state

δ_0 = the pre-camber (hogging) of the beam in the unloaded state.

δ_1 = the variation of the deflection of the beam due to the permanent loads immediately after loading.

δ_2 = the variation of the deflection of the beam due to the pedestrian loads plus any time dependent deformations due to the permanent loads.

\amalg represent an operator of deducing for opposite sign and ignoring for same convention sign.

- (c) The values given in Table 13.1 are empirical values. They are intended for comparison with the results of calculations and should not be interpreted as performance criteria.
- (d) In Table 13.1, L is the span of the beam, and for cantilever beams, the length L to be considered is twice the projecting length of the cantilever.

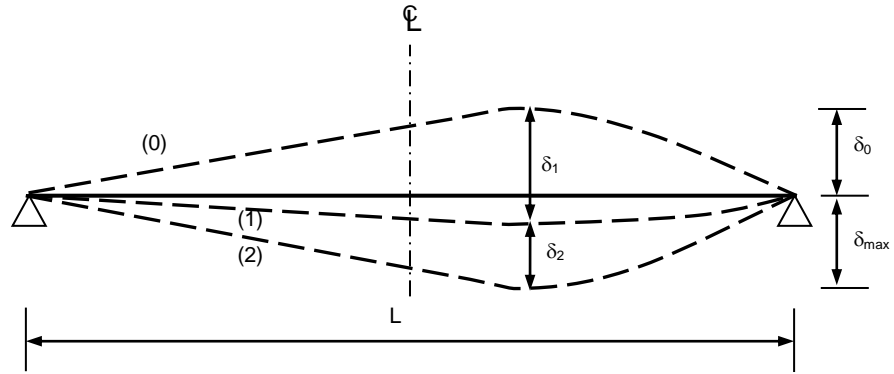

Figure 13.2 - Vertical deflections to be considered

Table 13.1 - Recommended limiting values for vertical deflections

Conditions	Limits (see Figure 13.2)	
	δ_{max}	δ_2
Footbridge Decks generally	L/250	L/300
Footbridge Roofs generally	L/200	L/250
Footbridge Roofs frequently carrying personnel other than for maintenance	L/250	L/300
Where δ_{max} can impair the appearance of the footbridge	L/250	-

13.6.3.3 Fatigue

13.6.3.3.1 General

Footbridges are under fatigue loads from pedestrians. The following measures can be taken to prevent excessive fatigues in footbridges.

- For a footbridge, when members are likely subject to crowd-induced vibration, a fatigue check for hot-rolled steelwork, hot finished and cold-finished structural hollow sections shall be required.
- Cold-formed steelwork should not be used for footbridges in which fatigue predominates, unless adequate data for the fatigue assessment are available.
- Fatigue consideration is included in the Code. Its inclusion does not imply that fatigue is likely to be a design criterion for footbridges.

13.6.3.3.2 Fatigue assessment

No fatigue assessment is required when any of the following conditions is satisfied:

- The largest nominal stress range $\Delta\sigma$ satisfies:

$$\gamma_{Ef}\Delta\sigma \leq \frac{26}{\gamma_{Mf}} \text{ N/mm}^2 \quad (13.10)$$

where γ_{Ef} and γ_{Mf} are partial safety factors described below.

- The total number of stress cycles N satisfies:

$$N \leq 2 \times 10^6 \left[\frac{36/\gamma_{Mf}}{\gamma_{Ef}\Delta\sigma_{E,2}} \right] \quad (13.11)$$

where γ_{Ef} and γ_{Mf} are partial safety factors described below, and $\Delta_{E,2}$ is the equivalent constant amplitude stress range in N/mm². The constant-amplitude stress range that would result in the same fatigue life as for the spectrum of variable-amplitude stress ranges, when the comparison is based on a Miner's summation. For convenience, the equivalent constant amplitude stress range may be related to a total number of 2 million variable amplitude stress range cycles.

- (c) For a detail for which a constant amplitude fatigue limit $\Delta\sigma_D$ is specified, the largest stress range (nominal or geometric as appropriate) $\Delta\sigma$ satisfies:

$$\gamma_{Ef}\Delta\sigma \leq \frac{\Delta\sigma_D}{\gamma_{Mf}} \quad (13.12)$$

where γ_{Ef} and γ_{Mf} are partial safety factors described below.

13.6.3.3.3 Partial safety factors

The values of the partial safety factors to be used shall be consistent with the codes used in design. For some special structures, ease of access for inspection or repair, likely frequency of inspection, maintenance and the consequences of failure may require special considerations.

13.6.3.3.4 Partial safety factor for fatigue loading

To take account of uncertainties in the fatigue response analysis, the design stress ranges for the fatigue assessment procedure shall incorporate a partial safety factor γ_{Ef} .

Unless otherwise stated, the following value of γ_{Ef} may be applied to the fatigue loading:

$$\gamma_{Ef} = 1.0 \quad (13.13)$$

13.6.3.3.5 Partial safety factor for fatigue strength

In the fatigue assessment procedure, in order to take account of uncertainties in the fatigue resistance, the design value of the fatigue strength shall be obtained by dividing by a partial safety factor γ_{Mf} .

Recommended values of the partial safety factor γ_{Mf} are given in Table 13.2. These values should be applied to the fatigue strength.

Table 13.2 - Partial safety factor for fatigue strength

Inspection and Access	Primary Components	Secondary Components
Periodic inspection and maintenance. Accessible joint detail.	1.25	1.00
Periodic inspection and maintenance. Poor Accessibility.	1.35	1.15

Notes for Table 13.2:

- (i) Inspection may detect fatigue cracks before subsequent damage is caused. Such inspection may be visual unless specified otherwise;
- (ii) In-service inspection may not be a requirement of the Code;
- (iii) Primary components refer to structural components where local failure of one component leads rapidly to failure of the structure; and
- (iv) Secondary components refer to structural components with reduced consequences of failure, such that the local failure of one component does not result in failure of the structure.

13.6.3.3.6 Fatigue assessment

- (a) If fatigue assessment is required, fatigue check could be carried out with reference to specialist literature.
- (b) A structural health monitoring system may be installed on a footbridge or sensors may be installed on the critical structural components of a footbridge for monitoring.

13.6.4 Vibration

Pedestrians can be adversely affected by the dynamic behaviour of footbridges. In addition to the criteria specified in section 5 on Human-Induced Vibration, the natural frequency of a footbridge shall not be less than 3 Hz. If the natural frequency of a footbridge is less than 3 Hz which may lead to unpleasant vibration, the maximum vertical acceleration, a_v , shall be limited to an appropriate value as given in recognized design guidelines in Annex A2.3 in order to avoid unpleasant vibration.

13.6.5 Bearing design for footbridges

Bearings should be located appropriately to allow sliding movement without causing damage to the structures. For detailed design consideration, local codes such as Structures Design Manual for Highways and Railways should be referred to.

13.7 DESIGN LOADS FROM OVERHEAD RUNWAY CRANES, TOWER AND DERRICK CRANES AND MOBILE CRANES

This section gives guidance on the loads which static cranes apply to building structures. The design of cranes themselves is a specialized activity which is not covered by the Code. Reference may be made to relevant crane design codes given in Appendix A1.10.

13.7.1 Types and classifications of static cranes

13.7.1.1 Overhead runway cranes

Overhead runway cranes comprise a main girder supported on rails at each end. The load is hoisted and carried by a trolley which traverses the main girder. The main girder can traverse along the end rails and thus the load can be moved in two perpendicular directions over the building area.

13.7.1.2 Tower and derrick (or luffing) cranes

Tower cranes consist of a horizontal girder attached to a vertical mast supported from a temporary base attached to the permanent building structure or on a separate foundation at a suitable location, e.g. a lift shaft or lightwell.

Derrick cranes are often used for steel erection in Hong Kong and are typically attached to a mast which is extended with the building in a similar way to that for tower cranes.

13.7.1.3 Mobile cranes

Mobile cranes may be lorry mounted, typically with a telescopic box section boom and supported on jacks attached to the crane by outriggers when in use.

Alternatively cranes may be mounted on a wide tracked base platform, typically with a trussed boom.

13.7.2 Design issues for crane support structures

Cranes will impose large and fluctuating loads on structures. If the crane is heavily used, then fatigue may need to be considered in the design of the supporting structural elements.

The dynamic effect of loads from cranes should be allowed for.

13.7.3 Loading from cranes

13.7.3.1 Loading from overhead travelling cranes

For overhead travelling cranes, the vertical and horizontal dynamic loads and impact effects should be established in consultation with the crane manufacturer.

Loads arise from the dead load of the crane, the live load being lifted, horizontal loads from braking, skewing and buffer collision loads. The loads should be increased by dynamic factors as described below.

In the absence of more precise information an increase of 25% on static vertical loads should be used. A horizontal load of 10% of vertical wheel loads should be taken transverse to the rails and 5% along the rails should be taken.

The partial load factors given in Table 13.3 for vertical loads from overhead travelling cranes should be applied to the dynamic vertical wheel loads, i.e. the static vertical wheel loads increased by the appropriate allowance for dynamic effects.

Where a structure or member is subject to loads from two or more cranes, the crane loads should be taken as the maximum vertical and horizontal loads acting simultaneously where this is reasonably possible. For overhead travelling cranes inside

buildings, the following principal combinations of loads should be taken into account in the design of gantry girders and their supports:

- Crane combination 1: Dead load, imposed load and vertical crane load;
- Crane combination 2: Dead load, imposed load and horizontal crane load;
- Crane combination 3: Dead load, imposed load, vertical crane load and horizontal crane load.

Table 13.3 - For normal condition design but with crane load

Load combination (including earth, water and temperature loading where present)	Load Type										
	Dead		Imposed		Earth and water	Wind	Temperature	Vertical crane loads		Horizontal Crane loads	
	G_k		Q_k		S_n	W_k	T_k				
	<i>Adverse</i>	<i>Beneficial</i>	<i>Adverse</i>	<i>Beneficial</i>				<i>Adverse</i>	<i>Beneficial</i>	<i>Adverse</i>	<i>Beneficial</i>
1. dead and imposed	1.4	1.0	1.6	0	1.4	-	1.2	1.4	1.0	-	-
	1.4	1.0	1.6	0	1.4	-	1.2	-	-	1.2	0
	1.4	1.0	1.6	0	1.4	-	1.2	1.4	1.0	1.2	0
2. dead and lateral	1.4	1.0	-	-	1.4	1.2	1.2	1.2	1.0	1.2	0
3. dead, lateral and imposed	1.2	1.0	1.2	0	1.2	1.2	1.2	1.2	1.0	1.2	0
4. dead and crane load	1.4	1.0	-	-	1.4	-	1.2	1.6	1.0	-	-
	1.4	1.0	-	-	1.4	-	1.2	-	-	1.6	0
	1.4	1.0	-	-	1.4	-	1.2	1.4	1.0	1.4	0

Where the action of earth or water loads can act beneficially, the partial load factor should not exceed 1.0. (The value of the partial load factor γ_f should be taken such that $\gamma_f \times$ the design earth or water load equals the actual earth or water load)

Where differential settlement is required to be considered a partial load factor of 1.4 shall be used in combinations 1, 2 and 4 and a partial load factor of 1.2 shall be used in combination 3.

13.7.3.2 Outdoor cranes

The wind loads on outdoor overhead travelling cranes under working conditions shall be obtained as follows:

- (a) Obtain the maximum value of in service wind speed at which the crane is designed to operate.
- (b) Calculate the wind load acting on the crane from this and apply to the supporting structure in the most unfavourable direction in combination with other crane loads as specified in clause 13.7.3.1.

The wind loads on outdoor overhead travelling cranes which are not in operation should be calculated using the HKWC.

13.7.3.3 Load combinations for overhead travelling cranes

Overhead travelling cranes having vertical and horizontal loads should be considered with other loads in combinations given in Table 13.3. The load factors in Table 13.3 shall be used for loads arising from overhead cranes. The lower value of 1.0 shall be used where the vertical load is beneficial, e.g. against overturning.

13.7.3.4 Loads from tower and derrick cranes

The Responsible Engineer will need to consider the temporary loads imposed on the permanent structure from a tower or derrick crane and to check the design of cranes since the cranes may be fabricated from countries with considerable difference in wind load against local condition. The Responsible Engineer shall obtain all the possible loads of the crane from the registered building contractor and tower crane supplier. These

combinations shall include loads in service and abnormal loads during typhoon winds. Resistance to uplift shall also be provided for.

13.7.3.5 *Loads from mobile cranes*

Parts of the permanent structure may be required to support mobile cranes during construction and in this case, the Responsible Engineer shall obtain loading data from the contractor or crane supplier. This data should include loads arising from an envelope of all boom positions in plan, slew and azimuth angles.

13.8 GUIDANCE ON MAINTENANCE OF STEEL STRUCTURES

13.8.1 General

Steel structures generally require relatively little maintenance provided that:

- (a) Appropriate protection system has been used at the time of construction.
- (b) There has been no significant change to the environment envisaged at the time this was specified.
- (c) There has been no external event that imposes forces in excess of those allowed for in the design.

The principal reasons for degradation of steel structures are:

- (a) Inadequate protection, leading to ongoing corrosion,
- (b) Fatigue,
- (c) Impact,
- (d) Excessive imposed movements, such as differential settlements.

It is the first two of these that generally lead to requirements for maintenance. More significant interventions may be needed, not generally classified as maintenance, for the other events.

By far the most common method of achieving protection to steelwork structures is through the application of a protective coating system. It should be appreciated that the use of coatings is not the only means of preventing steel from corroding.

There are issues that relate to maintenance of buildings in general and are not specific to steelwork structures. Moisture is probably the most common source of problems in buildings, and needs to be controlled. In addition to the provision of adequate ventilation within internal areas, it is essential to keep the roofing and rainwater disposal system (channels, gutters and down pipes) well maintained. Persistent leaks may be detrimental to the structure as well as to the finishes.

13.8.2 Consideration of maintenance in the original design

In specifying protection systems, it is important to ensure that the life of any system, including coatings, meets the client's requirements and the protective system should be properly installed/applied. Consideration should be given to the subsequent work that may be required during the design working life of the building.

Accessibility of steelwork in the completed building, either physically or in practical terms, e.g. where an external stanchion is built into the external wall, needs to be considered when specifying the original protection.

Site conditions may render access for maintenance not possible or disproportionately expensive. In such cases a protective system with a longer life to first maintenance or which assumes that the structure is inaccessible should be considered.

Features where water and dirt may collect should be avoided as these may lead to localised breakdown of protective coatings.

13.8.3 Maintenance of existing structures

For existing construction, there may be an ongoing maintenance regime that is assessed as adequate. Where a building is being taken on initially, the first stage will be to carry out an appraisal of the existing construction and its condition.

Where corrosion has occurred, it is unusual for this to be sufficiently widespread to cause structural damage. However, where structural damage has occurred, the necessary remedial measures fall beyond the scope of routine maintenance.

Once the necessary work has been carried out, an ongoing maintenance schedule will need to take into account of:

- (a) The site conditions and restrictions on access;
- (b) The use of the building (which may not be the same as for the original construction);
- (c) Any particular aesthetic requirements;
- (d) The required maintenance interval; and
- (e) The scope of maintenance work required, e.g. the need of off-site work for particular elements.

In those structures where fatigue is a design issue, or vibration is anticipated, holding-down bolts should be checked for tightness, any welded joints should be checked for cracking and bearings should be inspected.

13.8.4 Health and safety issues on maintenance

The key health and safety issues are:-

- (a) Access
- (b) Correct use of materials
- (c) Environmental considerations

Access includes consideration of how the necessary maintenance activities will be carried out safely, starting with the initial inspection and then progressing through the various procedures that may be required to ensure that the selected maintenance method can be carried out thoroughly and effectively.

Detailed method statements should be prepared for the different procedures, including risk assessments as relevant.

Manufacturer's instructions should be followed with respect to storage, handling and use of the different materials. This may include the use of protective clothing and the provision of adequate ventilation while painting and associated preparation is in progress. It is the Responsible Engineer's duty to ensure that carrying out of the work will not endanger the health and safety of the workers and of the general public. This requires inter alia the provision of screening and the safe disposal of any waste materials.

14 FABRICATION AND ERECTION

14.1 DIMENSIONS AND TOLERANCES OF SECTIONS

The dimensions and tolerances of hot rolled sections and cold-formed sections shall be in accordance with the essential requirements of the reference standards given in Annex A1.8.

14.2 WORKMANSHIP – GENERAL

14.2.1 Identification

At all stages of fabrication, each piece or package of similar pieces of steel components shall be identifiable by a suitable system. Completed components shall be identified so as to correspond to material certificates or test results. Completed components shall be marked with a durable and distinguishing erection mark in such a way as not to damage the material.

14.2.2 Handling

Steelwork shall be bundled, packed, handled and transported in a safe manner so as to avoid permanent distortion and minimise surface damage. Particular care shall be taken to stiffen free ends and adequately protect all machined surfaces.

14.2.3 Cutting

Unless the Responsible Engineer specifies otherwise, cutting may be performed by sawing, shearing, cropping, plasma arc cutting, laser cutting, flame cutting or machining. Hand-held flame cutting shall only be used where it is impractical to use machine flame cutting, and the resultant cut faces shall be dressed to remove irregularities.

The hardness of cut edges shall not exceed 380 Hv when tested in accordance with the requirements of the reference standards as given in Annex A1.8. This shall be demonstrated by a series of indentations across the cut face. The indentations shall be equally spaced and sampled along the centre of the plate edge. Cut surface shall be prepared carefully (avoiding heat or excessive material removal) so as not to affect metallurgically the hardness of the surface tested.

Cut edges shall be dressed to remove dross, burrs and irregularities. Sharp edges shall be dressed.

Re-entrant corners shall be rounded off with a minimum radius of 5 mm.

For steel with a design strength greater than 355 N/mm², shearing may only be used for material of thickness up to 10 mm unless special requirements are taken. In other cases, the cut face shall be ground down or machined to at least a depth of 0.5 mm to remove any significant defects.

Where steel with a design strength exceeding 460 N/mm², the cut faces shall be dressed to a depth of at least 0.5 mm irrespective of the plate thickness.

Columns and compression members designed to be in direct bearing shall be fabricated to the accuracy given in section 15.

14.2.4 Shaping and forming

Steel may be bent or pressed into shape either by hot or cold forming processes, provided that the properties of the worked material are not reduced below those specified.

Hot and cold forming shall conform to the relevant requirements of the relevant reference standards.

However, hot forming of quenched and tempered steel or cold formed thin gauge members and sheeting is not permitted.

14.2.5 Holing

14.2.5.1 Holes

Unless the Responsible Engineer specifies otherwise, round holes for fasteners or pins shall be drilled, punched or plasma cut. Slotted holes shall be punched, plasma cut or formed by drilling two holes and completed by cutting. Holes shall be dressed as required to remove burrs and protruding edges.

14.2.5.2 Tolerances on hole diameters

The tolerances on hole diameters shall be in accordance with the requirements given in Table 14.1.

Table 14.1 - Tolerances on hole diameters

Range of hole diameters (mm)		Tolerances for particular situation (mm)		
Above	Up to and including	Punched holes	Drilled Holes	Holes for fitted bolts
-	3	0.14	0.1	0.06
3	6	0.18	0.12	0.075
6	10	0.22	0.15	0.090
10	18	0.27	0.18	0.11
18	30	0.33	0.21	0.13
30	50	0.39	0.25	0.16
50	80	0.46	0.3	0.19

Note: Tolerances on holes are positive only i.e. negative tolerance is not permitted.

14.2.5.3 Matching

All matching holes for fasteners or pins shall register with each other so that fasteners can be inserted freely through assembled members in a direction at right angles to the faces in contact. Drifts may be used but holes shall not be distorted.

14.2.5.4 Drilling through more than one thickness

Where the separate parts are tightly clamped together, drilling shall be permitted through more than one thickness. The parts shall be separated after drilling and any burrs removed.

14.2.5.5 Punching full size

Punching full size is not permitted in material with a design strength exceeding 460 N/mm². Punching full size shall only be permitted in material with a design strength not exceeding 460 N/mm² when all the following conditions are satisfied:-

- The tolerance on distortion of the punched hole does not exceed that shown in section 15.
- The holes are free from burrs that should prevent solid seating of the parts when being tightened.
- Thickness is less than 25 mm for steel with a design strength not exceeding 355 N/mm² and not greater than 10 mm for higher grade steel.
- The thickness is also not greater than the diameter of the hole being punched.
- In spliced connections, the holes in mating surfaces shall be punched in one direction in all members.

14.2.5.6 Punching and reaming

If the above conditions are not satisfied, punching may be used provided that the holes are punched at least 2 mm less in diameter than the required size and the hole is reamed to the full diameter.

14.2.5.7 Fitted bolts and pins

Holes for fitted bolts and pins may either be match drilled together or reamed in situ. When they are reamed in situ, they shall initially be made at least 3 mm smaller in diameter by drilling or punching. Where the fastener is to fit through multiple plies, the components shall be held firmly together during drilling or reaming.

Pins shall be parallel throughout and shall have a smooth surface free from flaws. They shall be of sufficient length to ensure that all parts connected thereby bear fully on them. Where the ends are threaded, they shall be provided, where necessary, with a pilot nut to protect the thread.

The pin holes shall be bored smooth, straight and true to gauge and at right angles to the axis of the member. Boring shall be done only after the member is fully riveted, bolted or otherwise agreed with the Responsible Engineer.

For pins with diameter not exceeding 25 mm, the diameter of the pins shall be within tolerance of -0.25 mm to -0.4 mm and the diameter of the pin hole shall be within a tolerance of 0mm to +0.15 mm.

For pins with diameter exceeding 25 mm, the clearance between the pin and pin hole shall be not less than 0.4 mm and not more than 0.75 mm.

14.2.5.8 *Countersunk holes*

Countersinking of normal round holes for countersunk bolts and screws shall be carried out after holing. If countersunk bolts are identified as being for use in tension or preloaded applications, to allow for adverse tolerances, the nominal depth of countersinking shall be at least 2mm less than the nominal thickness of the outer ply.

14.2.6 **Assembly**

Connected elements shall be drawn together such that they achieve firm contact consistent with the requirements for fit up or direct bearing.

Drifting of holes to align the components shall be permitted, but must not cause damage or distortion to the final assembly.

Any requirements for camber or presets for incorporation in fabricated components shall be checked after completion of fabrication.

14.2.7 **Curving and straightening**

Curving or straightening components during fabrication, shall generally be performed by one of the following methods:-

- (i) mechanical means, taking care to minimise indentations, or change of cross-section. Cold bending may be applied provided the plastic strains induced do not exceed 3% and no welding takes place subsequently on the strained region, unless it complies with the requirements as given in clause 11.7.5. For bending of steels with design strength up to 460 N/mm² such that strains in excess of 3% are produced, either the bending shall be carried out hot at temperatures in the range 850 to 900°C or the component shall be heat treated by normalising after cold bending. Any materials subject to curving or straightening involving plastic strains in excess of 3% shall be demonstrated to retain the specified mechanical properties by a procedure test sample.
- (ii) the local application of heat, ensuring that the temperature of the metal is carefully controlled, and does not exceed 650°C.
- (iii) the induction bending process with careful temperature control.

Methods for curving and straightening which involve increased temperatures shall not be used for quenched and tempered steel.

After curving or straightening, welds within the area of curving or straightening shall be visually inspected. Non-destructive examination of welded joints, where required, shall be carried out after any curving or straightening.

14.2.8 **Inspection**

Sufficient components shall be checked for dimensional accuracy and conformity to design requirement to demonstrate that the manufacturing process is working satisfactorily.

14.2.9 Storage

14.2.9.1 *Stacking*

Fabricated components, which are stored prior to being transported or erected, shall be stacked clear of the ground and arranged, so that water cannot accumulate. They shall be kept clean and supported in such a manner as to avoid permanent distortion.

14.2.9.2 *Visible markings*

Individual components shall be stacked and marked in such a way as to ensure that they can be identified.

14.3 WORKMANSHIP – WELDING

14.3.1 General

All welding operations shall be consistent to one set of standard as given in Annex A1.4.1 and shall be applied strictly throughout the whole course of development. Welding shall be a metal arc process in accordance with other clauses given in this section and the requirements as given in Annex A1.4.1. In case of ambiguity, the more stringent requirements shall apply.

Joints shall be prepared in accordance with the requirements as given in Annex A1.4.1. Precautions shall be taken to ensure cleanliness of the connection prior to welding.

Welding of higher strength steel is covered by this section but account should be taken of the difference in procedures that will be required for these materials and possible defects, e.g. weld metal hydrogen cracking.

14.3.2 Welder qualification

14.3.2.1 *Certification of welder test*

Welder test shall be witnessed by a qualified welding inspector and certificates endorsed by an independent testing body. Welders shall be tested to meet the requirements as given in Annex A1.4.3.

14.3.3 Welding procedure specifications

14.3.3.1 *Preparation of procedure specifications*

Welding procedure specifications (WPS) shall be prepared in accordance with the requirements as given in Annex A1.4.2 and made available to the Responsible Engineer. They shall comply with the guidance to avoid hydrogen cracking and to provide adequate toughness in the heat affected zone.

Table 14.2a - Requirements for submission of welding procedure specifications

Weld Type	Weld Size	Approval of Welding Procedure
Butt Weld	≤ 4 mm	Not necessary
	> 4 mm	By a qualified welding inspector.
Fillet Weld	≤ 4 mm	Not necessary
	> 4mm	By a qualified welding inspector.

14.3.3.2 *Approval of procedure specifications and procedure tests*

All welding procedure tests shall be witnessed by a qualified welding inspector and all Welding Procedure Approval Records (WPAR) shall be endorsed by a qualified welding personnel. WPAR shall record all relevant information, including original material certificates (showing the carbon equivalent value), mechanical tests data and non-destructive test results.

14.3.3.3 *Availability of welding procedure specifications*

WPS shall be submitted for the approval of the Responsible Engineer prior to the commencement of the works.

WPS shall be provided for the welders prior to the commencement of the works and shall be made available to the concerned parties on request.

14.3.3.4 *Avoidance of lamellar tearing- requirement for through thickness properties*

The welding procedures should be chosen so as to minimise the risk of lamellar tearing. If necessary, material with through-thickness properties shall be used. Guidance on the choice of procedures and through-thickness grade is given in Annex A1.4.1.

14.3.3.5 *Centreline segregation*

Centreline segregation is a material deficiency that may exist within the centre of plate (concast) products and some sections. It can lead to local reductions in toughness and weldability that can cause cracking in tee butt and cruciform weld configurations.

The use of good welding practice and details may avoid this phenomenon, for example,

- Avoiding tee, butt or cruciform welds in which the attachment plate is thicker than the through plate;
- Minimising through-thickness tension especially at the edges of plates;
- Dressing any cut edges to remove any areas of increased hardness;
- Using smaller weld volumes;
- Developing weld details and processes that minimise the restraint to welds;
- Following the guidance on the avoidance of hydrogen cracking.

Where it is essential to avoid this phenomenon, either additional tests shall be carried out or the continuous casting route shall not be used to produce the material.

14.3.4 Assembly

14.3.4.1 *Fit-up*

Joints shall be fitted up to the dimensional accuracy required by the welding procedure to ensure that the quality in clause 14.3.6.7 is achieved.

14.3.4.2 *Jigs*

Fabrications assembled in jigs may be completely welded in the jig, or may be removed from the jig after tack welding.

14.3.4.3 *Tack welds*

Tack welds shall be made using the same procedure as the main weld (single run) or the root run of multi-run welds. Alternatively, they may be made using a satisfactory welding procedure test based on the proposed length of tack weld to be used. The minimum length of the tack shall be the lesser of 4 times the thickness of the thicker part or 50 mm.

Tack welds, which are made by a qualified welder and found satisfactory by visual inspection, may be incorporated into main welds.

Where tack welds are made in circumstances other than those identified above, they must be removed.

14.3.4.4 *Distortion control*

The sequence of welding a joint or a sequence of joints shall be such that distortion is minimised.

14.3.4.5 *Fabrication or erection attachments*

Welding of attachments required for fabrication or erection purposes shall be made in accordance with the requirements for a permanent weld.

When removal of attachments is necessary, they shall be flame cut or gouged at a point not less than 3 mm from the surface of the parent material. The residual material shall be ground flush and the affected area visually inspected. When parent metal thickness is greater than 20 mm it shall also be checked by magnetic particle inspection. Acceptance criteria are as set out in clause 14.3.6.7. Attachments shall not be removed by hammering.

14.3.4.6 *Extension pieces*

Where the profile of a weld is maintained to the free end of a run by the use of extension pieces, they shall be of material of a similar composition, but not necessarily the same grade, as the component. They shall be arranged so as to provide continuity of preparation

and shall be removed after completion of the weld and the end surface of the weld ground smooth.

14.3.4.7 *Production test plates*

Where production test plates are required for testing purposes, they shall be clamped in line with the joint. The grade of material, carbon equivalent value, and rolling direction shall match the parent plate, but need not be cut from the same plates or cast.

14.3.5 Non-destructive testing of parent material

Unless agree with the Responsible Engineer, areas of material thicker than 25 mm in tee and cruciform connections within 150 mm of the weld shall be ultrasonically inspected prior to welding. The qualified welding inspector shall report any laminations or any significant variations in attenuation.

14.3.6 Non-destructive testing of welds (NDT)

14.3.6.1 *Scope and frequency of inspection*

Visual inspection shall be carried out at all welds by a qualified welding inspector (see clause 14.3.6.3).

The scope and frequency of inspection using non-destructive testing (NDT) shall be in accordance with Table 14.3a. Inspection requirements may be reduced at the discretion of the Responsible Engineer, based upon satisfactory performance in the initial production demonstrated against the requirements. Conversely, where testing indicates that weld quality problems have occurred (in similar materials, assembly methods or welding procedures), non-destructive testing requirements should be increased and should be extended to non-mandatory components.

Where the requirement for inspection is less than 100%, the joints for testing shall cover all the different joint types, material grades and weld equipment. Apart from this the selection should be random.

14.3.6.2 *Record of testing*

Results of visual inspection, surface flaw detection and ultrasonic examination shall include the minimum requirement stipulated by the relevant standard and shall be available for inspections.

14.3.6.3 *Visual inspection of welds*

Visual inspection shall be made in accordance with guidance given in Annex A1.4.4 over the full length of all welds. Such inspection shall be performed before any required NDT inspection.

Any welds which will be rendered inaccessible by subsequent work shall be examined in accordance with the Code prior to the loss of access.

A suitably qualified person for visual inspection of welds may be a welding inspector who can provide evidence of having trained and assessed for competence in visual inspection of the relevant types of welds.

14.3.6.4 *Hold time before final NDT*

Owing to the risk of delayed cracking, a hold time period of at least 16 hours should generally be allowed before the final inspection is made of as-welded fabrications. This hold time should be reduced for thin materials whose yield strength is less than 690 N/mm² or should be increased for materials of combined thickness greater than 50 mm or of a yield strength over 690 N/mm². Typical hold times conforming with this requirement are illustrated in Table 14.2b. The hold time is the waiting time normally required after completion of welding. In high restraint situations (e.g. cruciform welds), the hold time might need to be increased; with evidence of continual satisfactory production, hold times might be reduced.

For material with a yield strength greater than 690N/mm², the hold time should be submitted by the Responsible Engineer based on the advice of a welding engineer or the supplier of the welding consumables, and Table 14.2b should not be used.

Table 14.2b - Illustrative hold times

Nominal Carbon Equivalent Value (CEV) ⁽²⁾	$\Sigma t^{(3)} < 30\text{mm}$	$\Sigma t^{(3)} \leq 60\text{mm}$	$\Sigma t^{(3)} \leq 90\text{mm}$	$\Sigma t^{(3)} > 90\text{mm}$
≤ 0.40	None	8 hours	16 hours	40 hours ⁽¹⁾
≤ 0.45	8 hours	16 hours	40 hours ⁽¹⁾	40 hours ⁽¹⁾
≤ 0.48	16 hours	40 hours ⁽¹⁾	40 hours ⁽¹⁾	40 hours ⁽¹⁾
≤ 0.65	40 hours ⁽¹⁾	40 hours ⁽¹⁾	40 hours ⁽¹⁾	40 hours ⁽¹⁾
> 0.65	48 hours ⁽¹⁾	48 hours ⁽¹⁾	48 hours ⁽¹⁾	48 hours ⁽¹⁾

Notes:

(1) Where the figures are in bold, generally, the advice of a welding engineer or the supplier of the welding consumables should be sought.

(2) The carbon equivalent value is that of the parent material to the International Institute of welding (IIW) formula and is calculated as follows:

$$CEV = C + \frac{Mn}{6} + \frac{Cr + Mo + V}{5} + \frac{Ni + Cu}{15} \quad (T14.1)$$

(3) Σt is the combined thickness as shown in Figure 14.1.

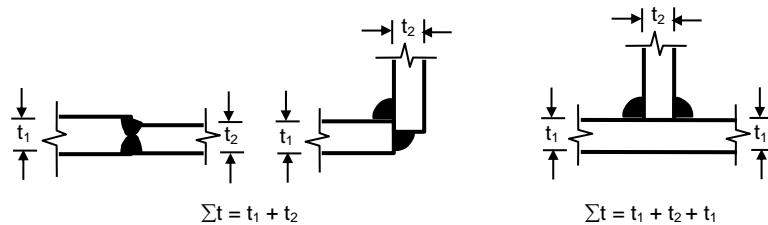

Figure 14.1 - Combined thickness

Whatever hold-time period is to be used shall be stated in the inspection records.

14.3.6.5 Surface flaw detection

Where a closer examination of a weld surface is required in accordance with Table 14.3a, magnetic particle inspection (MPI) shall be used. If magnetic particle inspection equipment is impractical, dye penetrant inspection (DPI) may be used.

Final surface flaw detection of a welded joint shall be carried out after completion of the weld in accordance with the hold time given in Table 14.2b.

Where a welding procedure requires an inspection after initial weld runs before further welding is performed, such inspections may be carried out when the weld metal has cooled to ambient temperature.

A suitably qualified person for surface flaw detection of welds may be a welding inspector or a welder, who holds a valid certificate of competence in surface flaw detection of the relevant types of welds, from BA or a nationally recognised authority.

Table 14.3a - Scope and frequency of inspection (NDT)

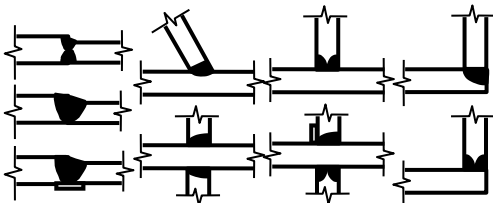
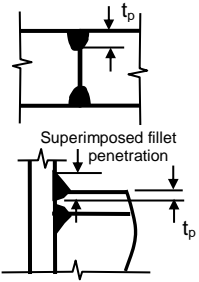
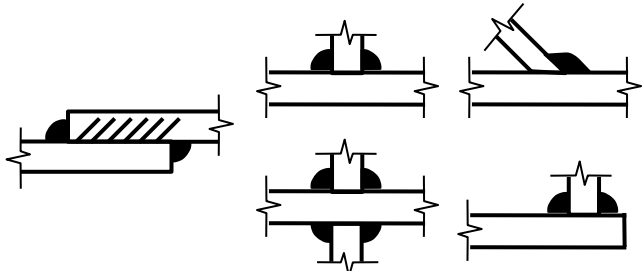
PART A		VISUAL INSPECTION Prior to Non-Destructive Testing (NDT) all welds to be visually inspected by a suitably qualified person (See clause 14.3.6.3)	
PART B		THICKNESS FOR MANDATORY NDT AND FREQUENCY OF TESTING (all dimensions in mm)	
WELD TYPE		BUTT	
		FULL PENETRATION	PARTIAL PENETRATION
			
MPI	Thickness	All thickness	All thickness
	Frequency	100%	20%
U/S	Thickness	$t_{max} \geq 10$	$t_p \geq 8$
	Frequency	100%	20%
WELD TYPE		FILLET	
			
MPI	Thickness	All thickness	
	Frequency	10%	
U/S	Thickness	Leg length ≥ 15	
	Frequency	10%	

Notes:

- 1 Longitudinal welds are those made parallel with the member axis. All other welds are transverse.
- 2 The size of fillet weld is identified in the table by the leg length.
- 3 MPI Magnetic Particle Inspection (see clause 14.3.6.5).
- 4 U/S Ultrasonic Examination (see clause 14.3.6.6).
- 5 For steels with a yield strength greater than 500N/mm² the frequency of testing should be 100% unless agreed otherwise by the Responsible Engineer.

14.3.6.6 *Ultrasonic examination*

Where ultrasonic examination (U/S) is required, it shall be made in accordance with the requirement as contained in Annex A1.4.4. Records of the inspection procedure shall be kept, connection types and locations shall be clearly identified and shall be available for inspection unless otherwise agreed by the Responsible Engineer.

Ultrasonic examination of the welded joint shall be carried out after completion of the weld in accordance with the hold time given in Table 14.2b.

Note: In addition to weld examination, through-thickness ultrasonic examination of the parent material may be necessary for weld geometries susceptible to lamellar tearing.

Operators carrying out final ultrasonic examination of the weld shall hold a valid certificate of competence from BA or a nationally recognised authority.

14.3.6.7 *Acceptance criteria and corrective action*

Unless otherwise specified, the acceptance criteria for welds shall meet the minimum requirement as contained in Table 14.3b. Welds that do not comply with the requirement shall be repaired.

The position of welds shall be within 10 mm of that shown on the drawings. The length of weld shall be not less than that shown on the drawings and should not exceed the specified length by more than 10 mm.

Any repairs shall be carried out in accordance with approved welding repair procedures.

Any corrected welds shall be inspected again with increased hold times and shall meet the requirements of the original welds.

In cases where fatigue can occur, acceptance standards more stringent than these minima shall be required. In such a case, the Responsible Engineer shall specify the additional acceptance requirements.

Table 14.3b - Acceptance criteria for welds in steel structures

Feature	Parameter	Weld type	Particular conditions ^a		Figure reference in Table 14.3d	Acceptance criteria for normal quality ^{b,c} (All dimensions in mm)	Remedial action for non-conforming welds ^d		
Overall weld geometry	Location ^e	All	—		—	$D \pm 10$	E		
	Weld type	All	—		—	D	E		
	Extent (length)	All	—		—	$D + 10 - 0$	E		
Profile discontinuities	Actual throat thickness	All	—		i, ii, iii	$a, s \geq D (50)$ $a, s \leq D + 5$	R DS		
	Leg length	Fillet	—		i	$z \geq D (50)$	E		
	Toe angle (interface and inter-run)	All	Transverse	—		i, ii	$\theta \geq 90^\circ$	DS/R	
			Longitudinal	—		i, ii	$\theta \geq 90^\circ$	DS/R	
	Excess weld metal	Butt	Transverse	—		ii	$h \leq 6$	DS	
			Longitudinal	—		ii	$h \leq 6$	DS	
Incomplete groove or concave root	Butt	Transverse	—		ii	$h \leq 0 (50)$	R		
		Longitudinal	—		ii	$h \leq 0.1t$	E		
Linear misalignment	Butt	All	Transverse butt	—		iv	$h \leq D + 0.2t$	E	
			Transverse cruciform	—		v	$h \leq D + 0.4t$	E	
			Longitudinal	—		iv, v	$h \leq D + 0.4t$	E	
Surface breaking discontinuities	Undercut ^f	All	Transverse (not lap joint)	—		iv, v	$h_1 + h_2 \leq 0.05t$ $l - NL$	R R	
			Fillet	Transverse (lap joint)	—		v	$h_1 + h_2 \leq 0.03t$ $l \leq 10$	R R
		All	Longitudinal	—		iv, v	$h_1 + h_2 \leq 0.1t$	R	
	Lack of root penetration	S/S Butt	Transverse	—		iii	NP	R	
			Longitudinal	—		iii	NP	R	
	Porosity	All	Transverse	—		vi	$d \leq 2$ $\sum d \leq 10 [100]$	R R	
			Longitudinal	—		vi	$d \leq 2$ $\sum d \leq 20 [100]$	R R	
Lack of fusion	All	—		vii	NP	R			
Cracks	All	At crater		—		vii	NP	R	
		Not at crater		—		vii	NP	R	
					vii	$h \leq 3$	R		
Sub-surface discontinuities	Lack of fusion/root penetration, slag lines	Butt	Transverse	Full depth	—		vii	$\sum l \leq 1.5t [100]$	R
				$h_1 < 6$	—		vii	$l \leq 10$ $l_1 \geq 10$	R R
				$h_1 > 6$	—		vii	$l - NL$ $l_1 - NL$	R R
			Longitudinal	Full depth	—		vii	$\sum l \leq 3t [100]$	R
				$h_1 < 6$	—		vii	$l - NL$ $l_1 - NL$	R R
				$h_1 > 6$	—		vii	$l - NL$ $l_1 - NL$	R R
—	Root gap	Fillet P/P Butt	—		i, v	$h \leq 2 (100), 3$	R		
—	Cracks	All	—		—	NP	R		
—	Lamellar tears	All	Transverse Longitudinal	—		—	NP ^g	E	

Table 14.3b - Acceptance criteria for welds in steel structures (cont'd)

Abbreviated terms		a	For definition of orientation see Table 14.3c.
D	As specified on drawings	b	Thickness applies to minimum member thickness at weld in question. For thicknesses greater than 20 mm "t" shall be taken as 20 mm. Where permitted size "h" if a discontinuity is related to "t" the maximum permitted value shall be not less than 0.3 mm in any case.
DS	Dress smoothly	c	Where more than one requirement is given both shall apply.
E	Refer to engineer	d	Where a repair is necessary an approved procedure shall be used.
NL	No limit	e	If on increasing the scope of inspection, further non-conformances are found, the scope shall be increased to 100% for the joint type in question.
NP	Not permitted (applies to discontinuities which are detectable by NDT methods in Table 14.3a)	f	Subject to any other locational requirements.
R	Repair by welding to approved procedure	g	"Lap" shall apply to any fillet welded attachment whose length in the longitudinal direction exceeds 50 mm.
≥	Greater than or equal to (i.e. not less than)		Lamellar tears may only be accepted in the longitudinal welds if the extent does not exceed limits for lack of fusion in transverse welds.
≤	Less than or equal to (i.e. not greater than)		
∑	Sum of		
()	Length of weld over which measurement may be averaged (mm)		
[]	Length of weld over which the summation is made (mm)		
L	Length parallel to the weld axis		
S/S	Single sided butt weld		
P/P	Partial penetration butt weld		

Table 14.3c - Definition of zones and weld orientation

Categories of joint types according to location and orientation in structure (see figure below)		Frequency of testing ^a
Connection zones	Shop welds	See table 14.3a
	Site welds	See table 14.3a
Member zones	Built-up members	See table 14.3a
	Transverse butts in web and flange plates before assembly	See table 14.3a
	Transverse fillet welds at ends of lap joints	See table 14.3a
	Longitudinal welds	See table 14.3a
	Secondary attachment welds e.g. for fixing purlins, side rails, buckling stiffeners etc.	See table 14.3a

Definition of zones and weld orientation

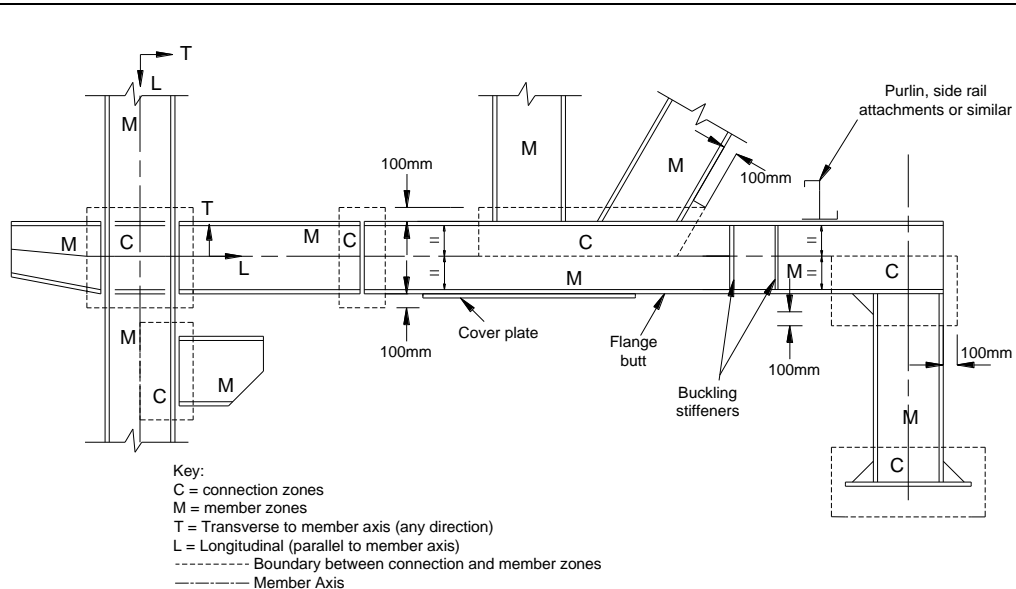

NOTE:- All welds in connection zones to be treated as transverse.

^a Where only partial inspection is required, the joints for testing shall be selected on a random basis, but ensuring that sampling covers the following variables as widely as possible: joint type, material grade and welding equipment.

Table 14.3d - Characteristic defects of welds in steel structures

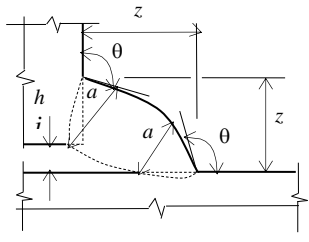
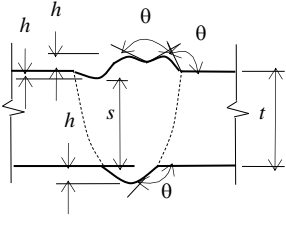
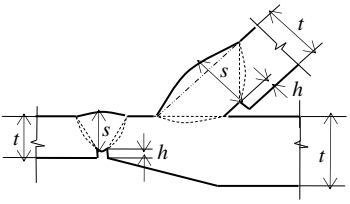
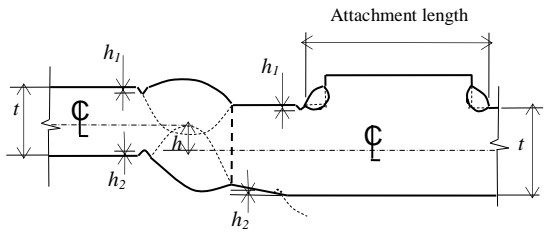
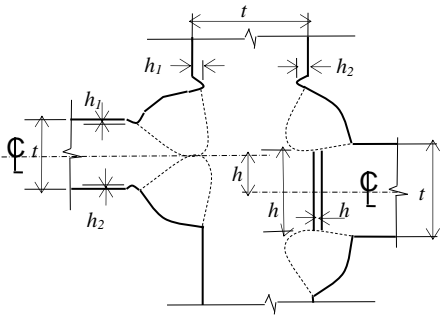
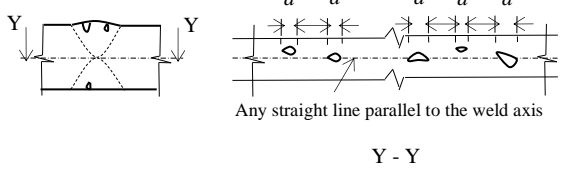
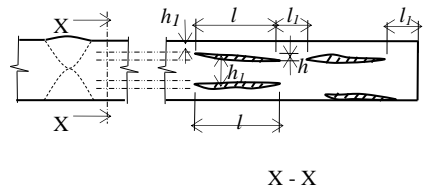
 <p>Figure (i)</p>	 <p>Figure (ii)</p>	 <p>Figure (iii)</p>
<p>a and s are minimum distances</p>		
 <p>Figure (iv)</p>	 <p>Figure (v)</p>	
 <p>Figure (vi)</p>	 <p>Figure (vii)</p>	

14.3.7 Shear stud welding

14.3.7.1 Method

Except where there are specific requirements in this section, shear studs shall be welded in accordance with the requirement given in Annex A1.4.1. Adequate earth return connections shall be made local to the area being stud welded.

14.3.7.2 Trial welding

When specified by the Responsible Engineer and before commencement of welding of studs, procedure trials shall be carried out. The trials shall be made on samples of material and studs representative of those to be used in the work.

At the start of each shift when stud welding is in progress, each welder shall perform the fixing of at least two trial studs.

14.3.7.3 Tests and inspection

All studs are to be visually inspected. They shall show a full 360° collar.

After a satisfactory visual inspection, bend tests shall be made at locations agreed with the Responsible Engineer. A minimum of 5% of the studs, but not less than two studs per beam shall be tested. The bend test shall be made by bending the head of the stud towards the nearer end of the beam, by means of a steel tube placed over the stud, until it is displaced laterally a distance of one quarter of the height of the stud. The stud weld shall not show any sign of cracking or lack of fusion.

If any stud is found to be defective, studs on either side shall be tested. Should either of the two additionally tested studs fail, then all studs shall be considered to be at risk until further testing deems them to be acceptable.

Studs subjected to the bend test shall not be straightened.

14.3.7.4 Defective studs

Studs with defective welding shall be replaced and re-tested as in clause 14.3.7.3.

If it is necessary to remove the defective stud, it shall be detached and the surface checked as described in clause 14.3.4.5.

14.4 WORKMANSHIP – BOLTING

14.4.1 General

This section covers bolting in the shop and on site. Bolts with an ultimate tensile strength exceeding 1000 N/mm² should not be used unless test results demonstrate their acceptability in a particular design application.

Separate components forming part of a common ply shall not differ in thickness by more than 2 mm generally or 1 mm in preloaded applications. If steel packing plates are provided to ensure that the difference in thickness does not exceed the above limit, their thickness shall not be less than 2 mm.

Packing plates shall have compatible corrosion behaviour and mechanical strength with the adjacent plate components of the joint.

14.4.2 Ordinary bolted assemblies

14.4.2.1 Hexagon bolt / nut combinations for ordinary (non-preloaded) assemblies

The combinations of bolts and nuts which may be used are given in Table 14.4.

Table 14.4 - Matching bolt, nut and washer standards for ordinary bolts

Standard	Grade	Bolt	Nut	Washer
European/ISO	4.6	BS EN ISO 4018 or BS EN ISO 4016	BS EN ISO 4034 (class 4 d>M16, class 5 d≤M16)	BS EN ISO 7091 (100HV)
	8.8 ⁽¹⁾	BS EN ISO 4017 or BS EN ISO 4014	BS EN ISO 4032 (class 8)	BS EN ISO 7091 (100HV)
	10.9 ⁽²⁾	BS EN ISO 4017 or BS EN ISO 4014	BS EN ISO 4032 (class 10)	BS EN ISO 7091 (100HV)
British	4.6	BS 4190 BS 7419	BS 4190 (Grade 4)	BS 4320
	8.8	BS 4190 BS 7419	BS 4190 (Grade 8)	BS 4320
	10.9	BS 4190	BS 4190 (Grade 10)	BS 4320
American	Equivalent to 8.8	ASTM A325	ASTM A563	ASTM F436
		F1852	ASTM A563	ASTM F436
		ASTM A490	ASTM A563	ASTM F436
Australian	4.6/S	AS/NZS 1111	AS/NZS 1111	AS/NZS 1111
	8.8/S	AS/NZS 1252	AS/NZS 1252	AS/NZS 1252
	8.8/TB	AS/NZS 1252	AS/NZS 1252	AS/NZS 1252
	8.8/TF ⁽⁶⁾	AS/NZS 1252	AS/NZS 1252	AS/NZS 1252
PR China	Normal bolt	GB1228	GB1229	GB1230
	High strength bolt	GB1231	GB1231	GB1231
	High strength bolt for torsion / shear type	GB3632 GB3633	GB3632 GB3633	GB3632 GB3633
Japanese JIS	4.6	JIS 1051	JIS 1051	JIS 1051
	6.8	JIS 1051	JIS 1051	JIS 1051

Notes: Any bolt assemblies which are seized when being tightened shall be replaced.
Normally, same strength grade of bolt and nut should be used together. Nuts of higher strength grade may be substituted for nuts of a lower strength grade.
When a thick protective coating is applied to a bolt of grade 8.8 or 10.9, which requires the nut thread to be overtapped, the next higher grade of nut should be used. That is,
(1) nuts for galvanized or sheradized 8.8 bolts shall be class/grade 10;
(2) nuts for sheradized 10.9 bolts shall be class/grade 12.

14.4.2.2 Cup and countersunk head bolt / nut assemblies

The combination of cup and countersunk bolts and nuts which may be used should be from matching acceptable standards as given in Annex A1.3.

14.4.2.3 Differing bolt grades

Different bolt grades of the same diameter shall not be used in the same structure.

14.4.2.4 Bolt length

For 8.8 grade bolts, the bolt length shall be chosen such that at least one complete thread in addition to the thread run-out that shall remain clear between the nut and the unthreaded shank of the bolt after tightening. For higher grades, at least five clear threads shall remain.

In all cases, at least one clear thread shall show between the nut and the end of the bolt after tightening.

14.4.2.5 Washers

When the members being connected have a finished surface protective treatment which may be damaged by the nut or bolt head being rotated, a washer shall be placed under the rotating part.

A suitable plate, or heavy duty washer shall be used under the head and nut when bolts are used to assemble components with oversize or slotted holes.

14.4.2.6 *Taper washers*

When the bolt head or nut is in contact with a surface which is inclined at more than 3° from a plane at right angles to the bolt axis, a taper washer shall be placed to achieve satisfactory bearing.

14.4.2.7 *Nuts*

Nuts shall be checked after being galvanized or sheradized for free running on the bolt and re-tapped if necessary to ensure a satisfactory tightening performance. Nuts of grade 8 or lower may be galvanized or sheradized while nuts of grade 10 or higher should only be sheradized.

14.4.2.8 *Tightening of assemblies with non-preloaded bolts*

The connected components shall be drawn together such that they achieve firm contact. Shims may be used to adjust the fit. For thicker gauge material ($t \geq 4$ mm for plates and $t \geq 8$ mm for sections), residual gaps up to 2 mm may be left between contact faces unless full contact bearing is specified.

During this process, each bolt assembly shall be brought into a snug-tight condition without overloading the bolts. In large bolt groups, this process shall be carried out progressively from the middle of the group to the outside. Additional cycles of tightening shall be carried out, if necessary, to achieve a uniform snug-tight condition. Sufficient precautions shall be taken so as not to overload short bolts (i.e. of length less than 3 times the diameter) and M12 or smaller bolts during tightening.

Note: the term snug-tight can generally be identified as that achievable by the effort of one man using a normal sized spanner without any extension arm, and can be set as the point at which a percussion drill starts hammering.

The snug tight tension in the bolt should not exceed the value at which bolt shear capacity reduces. Values of torque recommended by a typical bolt manufacturer to achieve suitable tensions for grade 8.8 bolts are as follows:

Table 14.5 - Recommended tightening torques and approximate bolt tensions for ISO grade 8.8 bolts (Assumes bolts oiled)

Nominal bolt diameter	Tightening torque (Nm)	Approximate bolt load (kN)
M16	55	17
M20	100	25
M22	110	25
M24	120	25
M27	135	25
M30	150	25
M33	165	25
M36	180	25

14.4.2.9 *Fitted bolts*

Precision bolts may be used as fitted bolts when holes are drilled or reamed after assembly so that the clearance in the hole is not more than 0.3 mm.

14.4.2.10 *Reaming*

Where parts cannot be brought together by drifting without distorting the steelwork, rectification may be made by reaming, provided the design of the connection will allow the use of larger diameter holes and bolts.

14.4.3 Pre-loaded bolt assemblies

14.4.3.1 *Bolt / nut / washer combinations*

The combination of pre-loaded bolt and nut and washers which may be used shall be from matching acceptable standards as given in Annex A1.3. The hardened washer is to be

placed under the nut or head being turned. Where oversized or slotted holes are present in the outer plies, suitable cover plates and/or additional hardened washers shall be used.

14.4.3.2 *Other pre-loaded assemblies*

The combination of pre-loaded assemblies shall be in accordance with manufacturer's recommendations.

14.4.3.3 *Tightening of pre-loaded bolt assemblies*

The use of friction grip bolts shall comply with the specification as contained in Annex A1.3.

Connected parts intended to transfer force in friction shall be firmly drawn together with all bolts partially tightened in a similar manner to assemblies with non-preloaded bolts. The joint shall then be examined to establish if there is any remaining gap which may affect the integrity of the joint. If so, then the joint shall be taken apart and a pack inserted before recommencing the tightening procedure. Tightening procedures shall be carried out progressively from the middle of each bolt group to the free edges. Additional cycles of tightening shall be carried out, if necessary, to achieve uniform preloading.

Unless specified by the Responsible Engineer, tightening, which shall comply with requirements in Annex A1.3, may be achieved by the torque control method, part-turn method, direct tension indicators or following the manufacturer's recommendations.

14.4.3.4 *Bolt length*

For normal grade HSFG bolts, the bolt length shall be chosen such that at least three complete threads in addition to the thread run-out that shall remain clear between the nut and the unthreaded shank of the bolt after tightening.

For higher grade, at least five clear threads shall remain.

In all cases, at least one clear thread shall show above the nut.

14.4.3.5 *Calibration of torque equipment*

Torque spanners and other devices shall have a calibration check at least once per shift, and shall be re-calibrated where necessary.

14.4.3.6 *Discarded bolt assemblies*

If, after complete tightening, a bolt or nut has to be slackened off, the whole bolt assembly is to be scrapped.

14.4.3.7 *Reaming*

Where parts cannot be brought together by drifting without distorting the steelwork, rectification can be made by reaming, provided that the design of the connection will allow the use of larger diameter bolts.

Calculations shall be made to demonstrate that the connection remains adequate for the forces in the connection.

14.5 **WORKMANSHIP – ERECTION**

14.5.1 **Erection method statement**

An erection method statement shall be prepared and shall be checked in accordance with the design rules, notably against resistance of the partly erected structure to erection and other temporary loading. It shall describe the procedures to be used for safe erection of the steelwork by taking into account the technical requirements on the safety of the works.

14.5.2 **Handling and storage**

Components shall be handled and safely stacked in such a manner as to minimise the risk of surface abrasion and damage. Fasteners and small fittings shall be stored under cover in dry conditions.

14.5.3 Damaged steelwork

Any steelwork damaged during off-loading, transportation, storage or erection shall be abandoned unless it is restored to conform to the standards of manufacture as given in the Code.

14.5.4 Column base plates and slabs

Steel packings shall be supplied to allow the structure to be properly lined and levelled and of sufficient size to avoid local crushing of the concrete.

Base packings shall be placed so that they do not prevent subsequent grouting to completely fill all spaces directly under the base plates. Base packings may be left permanently in place.

14.5.5 Grouting

Grouting shall not be carried out under column base plates until a sufficient portion of the structure has been aligned, levelled, plumbed and adequately braced.

Immediately before grouting, the space under column base plates shall be clean and free of all extraneous matter.

14.5.6 Stability

Throughout the erection of the structure, the steelwork shall be securely bolted or fastened in order to ensure that it can adequately withstand all loading to be encountered during erection, including, where necessary, those from the erection plant and its operation. Any temporary bracing or temporary restraint shall be left in position until erection is sufficiently advanced to leave the remaining structure in a stable and safe condition.

14.5.7 Alignment of part of the structure

Each part of the structure shall be aligned as soon as practicable after it has been erected. Permanent connections shall not be made between members until a sufficient part of the structure has been aligned, levelled, plumbed and temporarily connected to ensure that members will not be displaced during subsequent erection or alignment of the remainder of the structure.

14.5.8 Temperature effects

Due account shall be taken of the effects of temperature on the structure and on tapes and instruments when measurements are made for setting out, during erection, and for subsequent dimensional checks. The reference temperature shall be 20°C.

14.5.9 Site welding

Site welding shall be carried out in accordance with clause 14.3.

In all cases, precautions are to be taken so that the welding current does not damage the components it passes through and adequate earth return connections are made local to the area being welded.

Welding shall not be permitted during inclement weather, unless adequate protective measures are taken.

14.5.10 Site bolting

Bolting shall be carried out in accordance with clause 14.4.

14.6 PROTECTIVE TREATMENT

14.6.1 General

14.6.1.1 Specification

The specification should comply with the appropriate regulatory requirements on environmental protection.

Unless otherwise agreed, a single source of coating supply shall be used.

14.6.1.2 Method statement

Before the application or reapplication of protective coating, a detailed method statement shall be prepared.

14.6.1.3 Coating procedures

Coating materials shall be prepared and applied to surfaces in accordance with the manufacturer's recommendations.

14.6.1.4 Transportation, handling and storage of coated steelwork

The procedures for the transportation, handling and storage of coated steelwork shall be so arranged as to minimise the risk of damage to the coating.

14.6.2 Materials

14.6.2.1 Metallic blast cleaning abrasives

Abrasives used for blast cleaning shall be capable of achieving the specified level of cleanliness and surface roughness. Where metal abrasives are used, they shall comply with the specification as given in Annex A1.9.

14.6.2.2 Surface coatings

Paint materials and other coatings shall be in accordance with the appropriate European, ISO or other standard recognised in Hong Kong.

14.6.2.3 Sheradized coatings

Sheradized coatings shall be in accordance with the specification as given in Annex A1.9.

14.6.2.4 Galvanized materials

The composition of zinc in the galvanizing bath shall be in accordance with the specification as given in Annex A1.9.

14.6.3 Surface preparation

14.6.3.1 Surface cleanliness

At the time of coating, the surface cleanliness of the steelwork to be coated shall be in accordance with the grade specified and general local practice or BA's requirements.

14.6.3.2 Surface profile

The surface profile of the steelwork shall be that recommended by the coating manufacturer as compatible with the coating when graded.

14.6.3.3 Measurement of surface profile

Measurement of the surface profile of steelwork to be coated shall be made using the methods given in Annex A1.8.

14.6.3.4 Surface defects

Surface defects revealed during surface preparation shall be rectified accordingly.

14.6.4 Sprayed metal coatings

14.6.4.1 Procedures

Zinc or aluminium sprayed coatings shall be applied to the surface as required to a thickness given in the project specification or in the design drawings.

14.6.4.2 Reinstatement of damaged coating

All reinstatement of damaged coatings shall be made good to the standard of the original works using the same methods and materials.

14.6.4.3 *Sealing before painting*
Where a sprayed metal coating is to be overcoated subsequently, it shall be sealed before the application of the overcoating.

14.6.5 Hot-dip galvanizing

14.6.5.1 *Procedures*
Galvanizing shall be carried out in accordance with the requirements as contained in Annex A1.9.

14.6.5.2 *Vent holes*
The Steelwork Fabricator shall agree with the Responsible Engineer the position of vent and drainage holes in hollow members and requirements for subsequent sealing.

14.6.6 Paint treatments

14.6.6.1 *Surface preparation prior to painting*
Steelwork shall be prepared for coating to the standard specified.

14.6.6.2 *Painting of site weld areas and fasteners*
Site weld areas and fasteners which are not suitably protected shall be painted with an approved paint system to ensure similar properties, performance and compatibility with the protective treatment system being used on the surrounding surfaces.

Fasteners and bolt assemblies, which are supplied with a protective treatment that is equivalent to the protective treatment on the steelwork, need not be painted.

14.6.7 Inspection and testing

The method statement (clause 14.6.1.2) shall include proposals for inspection and testing to demonstrate compliance with the specified system.

15 ACCURACY OF FABRICATION AND ERECTION

15.1 GENERAL

This section gives guidance on the permitted deviations in dimensions of the steelwork during fabrication and after erection.

The accumulation in permitted deviations in the pieces supplied and in fabrication shall not cause the structure to be erected outside the permitted deviations for erection.

Where it is permissible to combine permitted deviations to establish the acceptability of the position of a piece of steelwork, they shall be combined using the root sum square method.

The permitted deviations (Δ) for various sections and components are given in the clauses and diagrams below.

Unless specified otherwise, permitted deviations refer to the unstressed condition.

Tolerance should in no circumstance affect the functionality of the permanent and temporary structure or its components.

15.2 PERMITTED DEVIATIONS IN THE CROSS SECTION OF ROLLED COMPONENTS

The permitted deviation in the cross section of rolled components after fabrication shall be as given in the product standards, see clause 14.1.

15.3 PERMITTED DEVIATIONS IN COMPONENTS AFTER FABRICATION

15.3.1 Squareness of ends not prepared for bearing

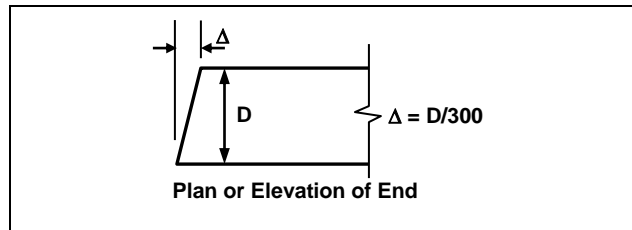

15.3.2 Squareness of ends prepared for bearing

Prepare ends with respect to the longitudinal axis of the member.

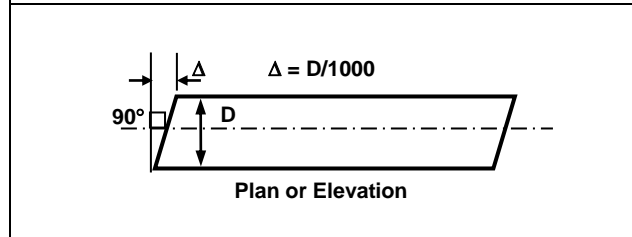

15.3.3 Straightness on both axes or of individual webs or flanges

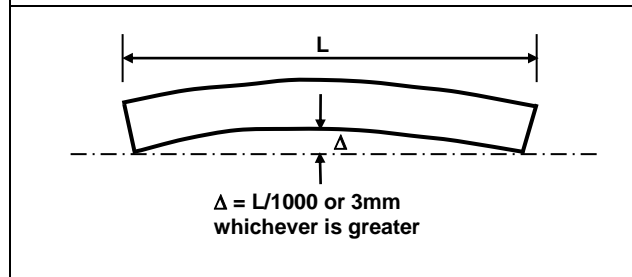

15.3.4 Length

Length measured on the centre line of the section or on the corner of angles.

For cut length $\Delta = 2+L/5000$ mm.

For components with both ends prepared for full contact bearing including end plates as applicable $\Delta = 1$ mm.

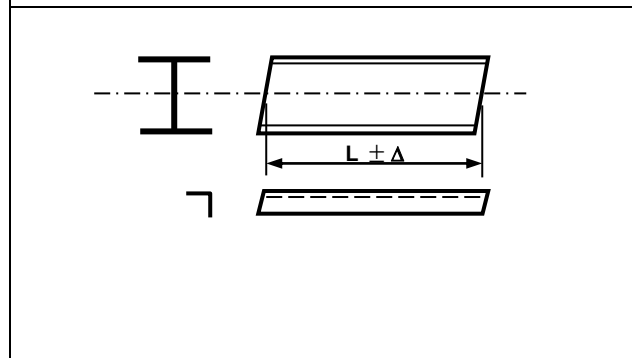

15.3.5 Curved or cambered

Deviation from intended curve or camber at mid-length of curved portion when measured with web horizontal.

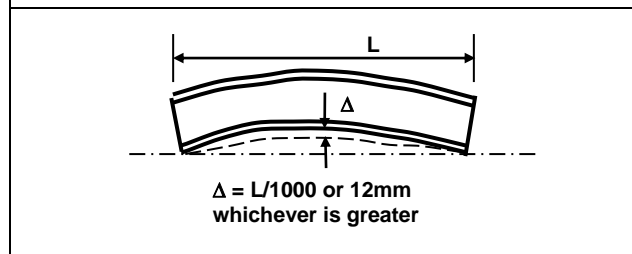

15.3.6 Squareness at bearings

Verticality of web at supports, for components without bearing stiffeners.

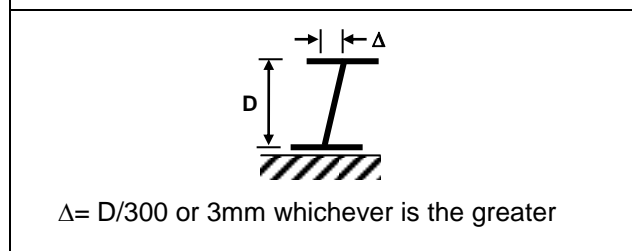

15.4 PERMITTED DEVIATIONS FOR ELEMENTS OF FABRICATED MEMBERS

15.4.1 Position of fittings

For fittings and components whose location is critical to the force path in the structure, the deviation from the intended position shall not exceed 3mm.

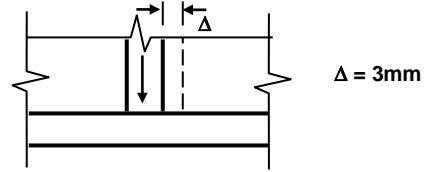

15.4.2 Position of holes

The deviation from the intended position of an isolated hole, also a group of holes, relative to each other shall not exceed 2mm.

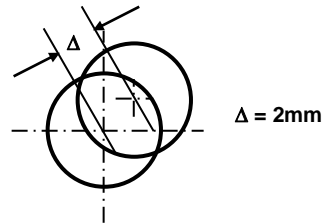

15.4.3 Punched holes

The distortion caused by a punched hole shall not exceed Δ .

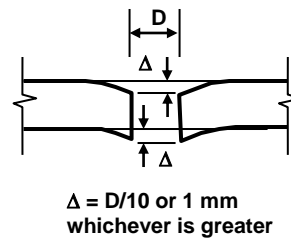

15.4.4 Sheared or cropped edges of plates or angles

The deviation from a 90° edge shall not exceed Δ .

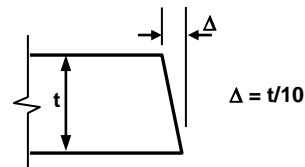

15.4.5 Flatness

Where full contact bearing is specified, the flatness shall be such that when measured against a straight edge which is laid against the full bearing surface in any direction, the gap shall not exceed Δ .

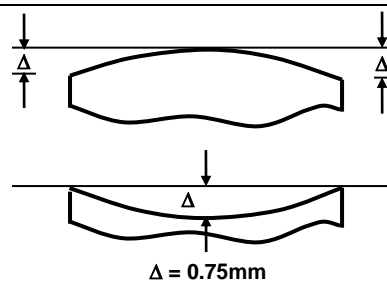

15.4.6 Notches

Depth and length of notch cut in the end of a section.

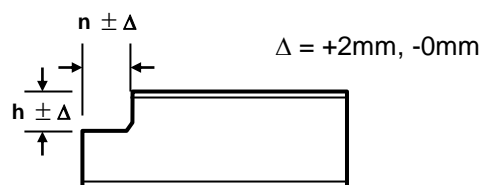

15.4.7 Column base plates

Centroid of column relative to specified location on the cap or base plate.

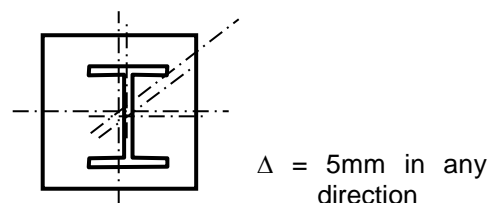

15.5 PERMITTED DEVIATIONS IN PLATE GIRDER SECTIONS

15.5.1 Depth

Depth on centre line.

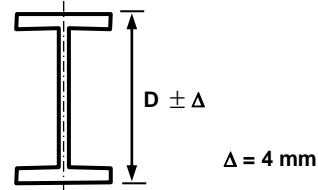

15.5.2 Flange width

Width of B_w or B_n .

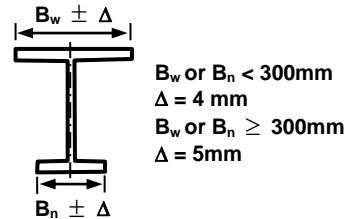

15.5.3 Squareness of section

Out of squareness of flanges.

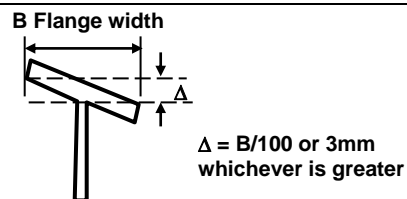

15.5.4 Web eccentricity

Intended position of web from one edge of flange.

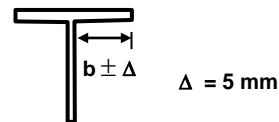

15.5.5 Flanges

Out of flatness.

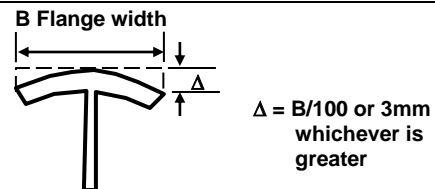

15.5.6 Top flange of crane girder

Out of flatness where the rail seats.

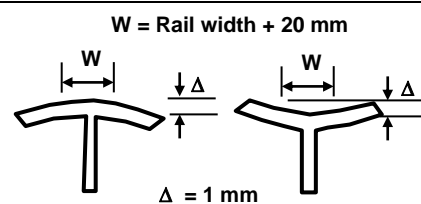

15.5.7 Web distortion

Distortion on web depth or gauge length.

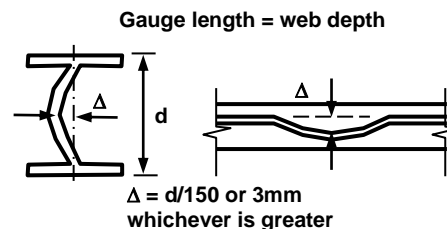

15.5.8 Cross section at bearings

Squareness of flanges to web.

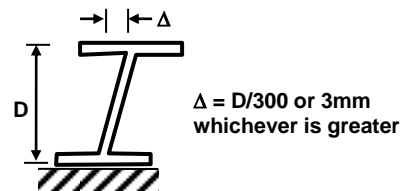

15.6 PERMITTED DEVIATIONS IN FABRICATED BOX SECTIONS

15.6.1 Plate widths

Width of B_f or B_w .

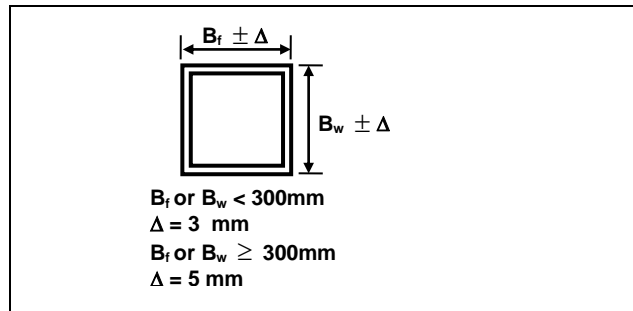

15.6.2 Squareness

Squareness at diaphragm positions.

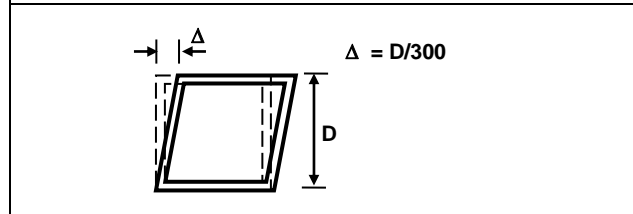

15.6.3 Plate distortion

Distortion on width or gauge length.

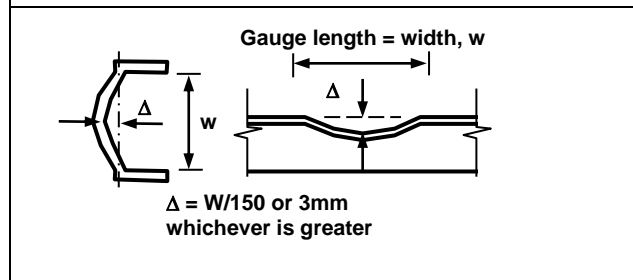

15.7 PERMITTED DEVIATIONS OF STIFFENERS

15.7.1 Web stiffeners

Straightness out of plane to plate after welding.

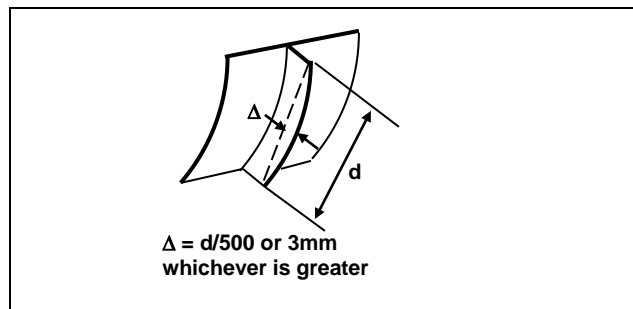

15.7.2 Web stiffeners

Straightness in plane with plate after welding.

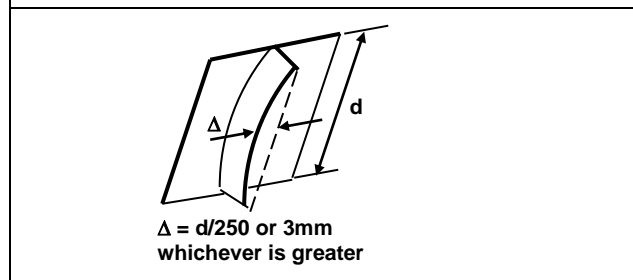

15.8 PERMITTED DEVIATIONS OF LATTICE COMPONENTS

15.8.1 Panel length

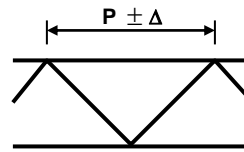

$$\Delta = 5\text{mm}$$

15.8.2 Cumulative length of panels

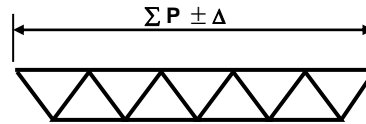

$$\Delta = 10\text{mm}$$

15.8.3 Joint eccentricity

Measured relative to any specified eccentricity.

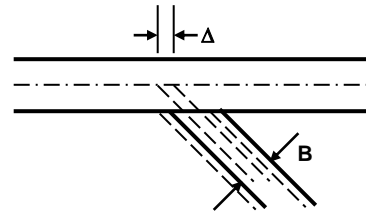

$$\Delta = B/20 + 5\text{mm}$$

15.8.4 Overall cross section

Overall depth D , the same permitted deviations apply to the width and diagonal dimension.

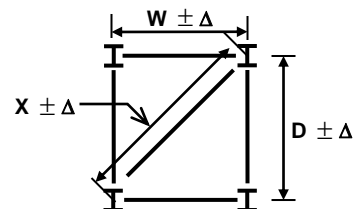

$$\begin{aligned} D, X \text{ or } W \leq 300\text{mm} & \Delta = 3\text{mm} \\ 300 < D, X \text{ or } W < 1000\text{mm} & \Delta = 5\text{mm} \\ D, X \text{ or } W \geq 1000\text{mm} & \Delta = 10\text{mm} \end{aligned}$$

15.8.5 Tubular lattice girders;

Gap between adjacent brace.

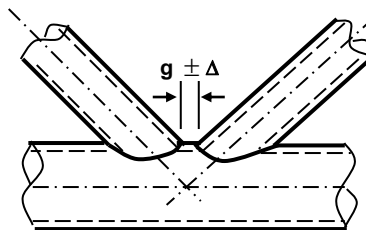

$$\Delta = 5\text{mm}$$

15.9 PERMITTED DEVIATIONS OF COLD FORMED SECTIONS

15.9.1 Position of measurement

Cross-sectional dimensions, other than thickness, shall be measured at points not less than 200 mm from the ends of the member.

15.9.2 Thickness

The thickness tolerances shall be as given in the product standard.

15.9.3 External dimensions

In open sections and sheet profiles, which are meant for cold formed thin gauge sections up to 4 mm thick, the permitted deviations on the external dimensions of cross sections of internal elements bounded by two corner radii shall be as given in Table 15.1. For an outstand element bounded by a corner radius and a free edge, the permitted deviations shall be as given in Table 15.2.

For closed hollow sections up to 22 mm thick, the permitted deviations on external dimensions of cross sections should refer to relevant standards.

Table 15.1 - Permitted deviations for the width of internal elements

Wall thickness t	Nominal width of internal element			
	$B \leq 50$	$50 < B \leq 100$	$100 < B \leq 200$	$B > 200$
$t < 3$	0.75	1.0	1.25	2.0
$3 \leq t < 6$	1.0	1.25	1.5	2.5
$6 \leq t < 8$	1.25	1.5	1.75	3.0

Note: All dimensions are in mm

Table 15.2 - Permitted deviations for the width of outstand elements

Condition	Thickness t	Nominal plate width	Permitted deviation
Milled edge	$t < 3$	≤ 110	2.0
	$3 \leq t < 8$	≤ 110	3.0
Sheared edge	$t < 3$	≤ 110	1.0
	$3 \leq t < 8$	≤ 110	1.75

Note: All dimensions in mm

15.9.4 Length

The length of a member shall not deviate from its specified length by more than 3 mm.

15.9.5 Angular tolerance

The angle between adjacent elements of a section shall not deviate from the specified angle by more than 1°.

15.9.6 Straightness

The deviation Δ of a member from straightness (or its intended shape) shall not exceed 3 mm or $L/1000$, whichever is the greater. In the case of complex cross sections, such as markedly asymmetric sections, the permitted deviations shall be agreed between the Responsible Engineer and the manufacturer.

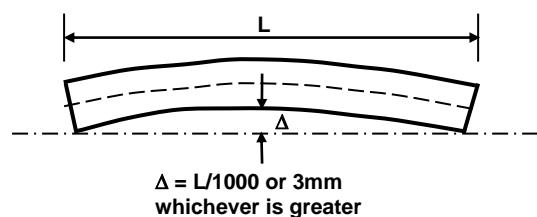

15.9.7 Angle of twist

The angle of twist shall not exceed $1^\circ/\text{m}$ of length. In the case of complex cross sections, the permissible angle of twist shall be agreed at the time of enquiry and order.

15.9.8 Compound members

Permissible deviations in the dimensions of compound members made up from two or more sections and built up structural elements, such as lattice girders, shall be agreed between the designer and the fabricator or manufacturer.

15.9.9 Flatness

The distortion of the surface of an element in a concave or convex direction shall not exceed $B/50$ where B is the width of the element.

15.10 PERMITTED DEVIATIONS FOR FOUNDATIONS, WALLS AND HOLDING DOWN BOLTS

15.10.1 Foundation level

Deviation from exact level.

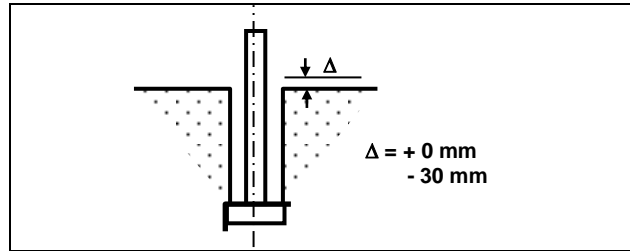

15.10.2 Vertical wall

Deviation from exact position at steelwork support point.

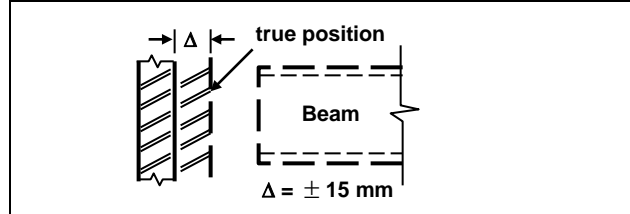

15.10.3 Pre-set foundation bolt or bolt groups when prepared for adjustment

Deviation from specified position.

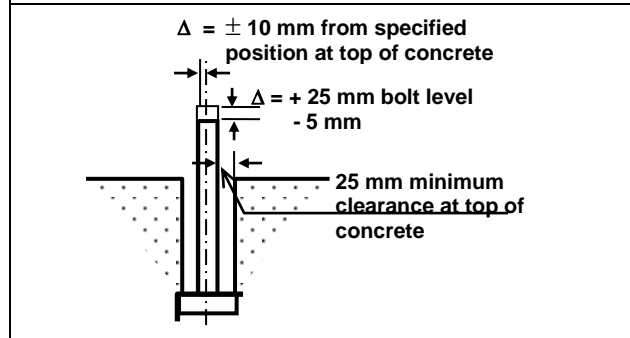

15.10.4 Pre-set foundation bolt or bolt groups when not prepared for adjustment

Deviation from specified position.

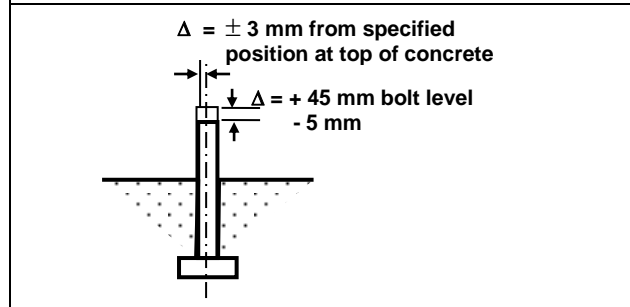

15.10.5 Pre-set wall bolt or bolt groups when not prepared for adjustment

Deviation from specified position.

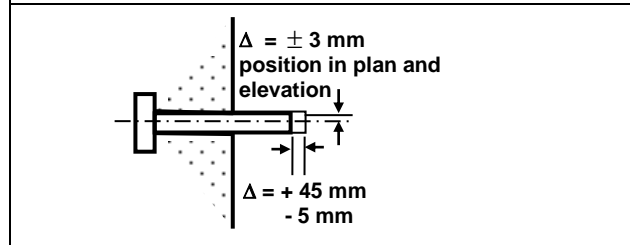

15.10.6 Embedded steel anchor plate

Deviation from the required location and level.

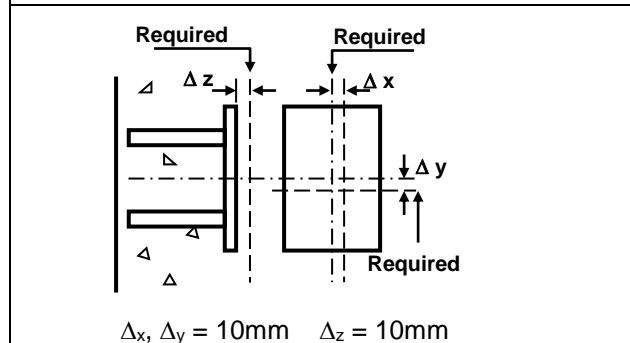

15.11 APPLICATION OF PERMITTED DEVIATION FOR ERECTED COMPONENTS

Permitted maximum deviations in erected steelwork shall be as specified in clause 15.12 taking into account of the following:

- (i) All measurements be taken in calm weather, and due note is to be taken of temperature effects on the structure.
- (ii) The deviations shown for I sections apply also to box and tubular sections.
- (iii) Where deviations are shown relative to nominal centrelines of the section, the permitted deviation on cross-section and straightness may be added.

15.12 PERMITTED DEVIATIONS OF ERECTED COMPONENTS AND STRUCTURES

15.12.1 Position of columns at base

Deviation of section centreline from the specified position.

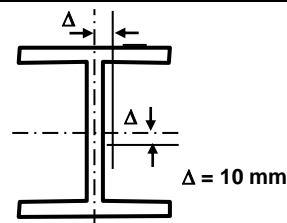

15.12.2 Overall plan dimensions

Deviation in length or width.

True overall dimension $L \leq 30\text{m}$
 $\Delta = 20\text{mm}$
 True overall dimension $L > 30\text{m}$
 $\Delta = 20\text{mm} + 0.25(L - 30)\text{mm}$
 L is the maximum dimension in metres

15.12.3 Single storey columns plumb

Deviation of top relative to base, excluding portal frame columns, on main axes.

NB for portal frames the frame may need to be preset to achieve this tolerance.

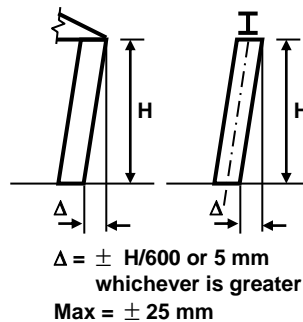

15.12.4 Multi-storey columns plumb

Deviation in each storey and maximum deviation relative to base. (It is recommended that checks on plumb be carried out at least every five stories)

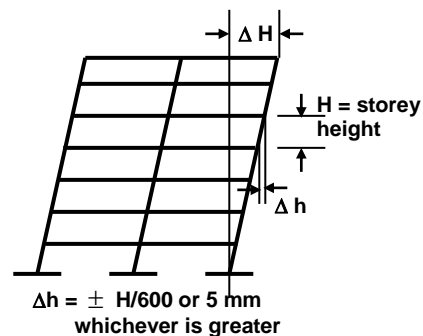

$\Delta H = \text{max } 50\text{mm}$ typically (at any level)
 $\Delta H = \text{max } 25\text{mm}$ for columns adjacent to lift shafts

15.12.5 Alignment of columns at splice

Deviation in the centreline of adjacent columns at a splice.

$\Delta = 5\text{mm}$ about either axis

15.12.6 Location of column splice

Deviation compared to a straight line joining connection points at adjacent storey levels.

$\Delta = s/500$ where s is the distance to the nearest floor

15.12.7 Gap between bearing surfaces

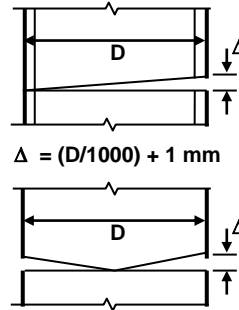

15.12.8 Alignment of adjacent perimeter columns

Deviation relative to next column on a line parallel to the grid line when measured at base or splice level.

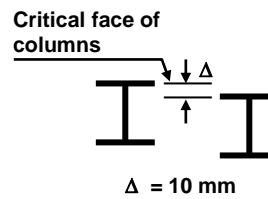

15.12.9 Beam level

Deviation from specified level at supporting column.

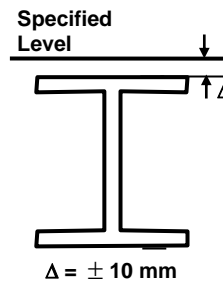

15.12.10 Level at each end of same beam

Relative deviation in level at ends.

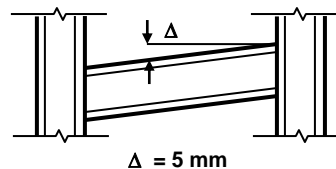

15.12.11 Level of adjacent beams within a distance of 5 metres

Deviation from relative horizontal levels (measured on centreline of top flange).

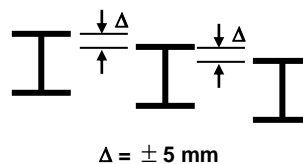

15.12.12 Level of beams at adjacent floors

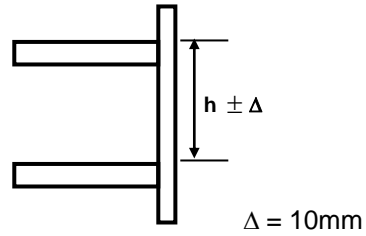

15.12.13 Beam alignment

Horizontal deviation relative to an adjacent beam above or below.

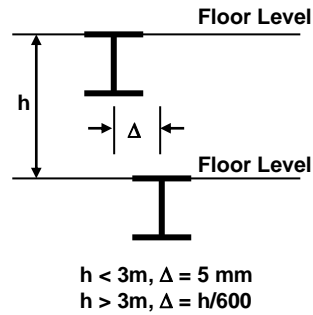

15.12.14 Position in plan of members

Deviation in the specified position of members other than columns relative to adjacent columns.

$\Delta = 5\text{mm}$

15.12.15 Crane gantry columns plumb

Deviation of cap relative to base.

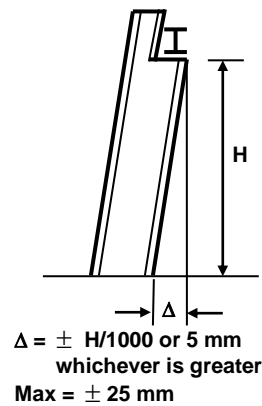

15.12.16 Crane gantries gauge of rail tracks

Deviation from true gauge.

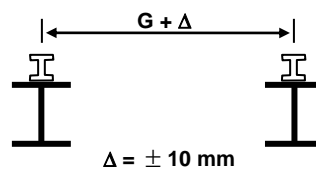

15.12.17 Joints in gantry crane rails – rail surface

Deviation in level at rail joint.

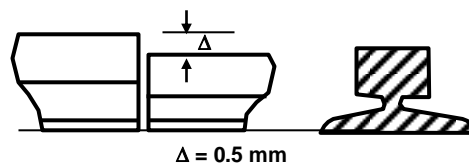

15.12.18 Joints in gantry crane rails – rail edge

Deviation in line at rail joint.

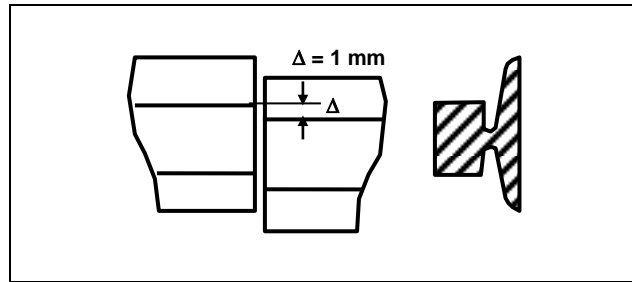

15.12.19 Profile steel floor decking

Deviation of dimension between deck edge trim and perimeter beam.

Note : Deviation (as shown) between actual beam centre line and intended beam centre line arises from other permitted tolerances.

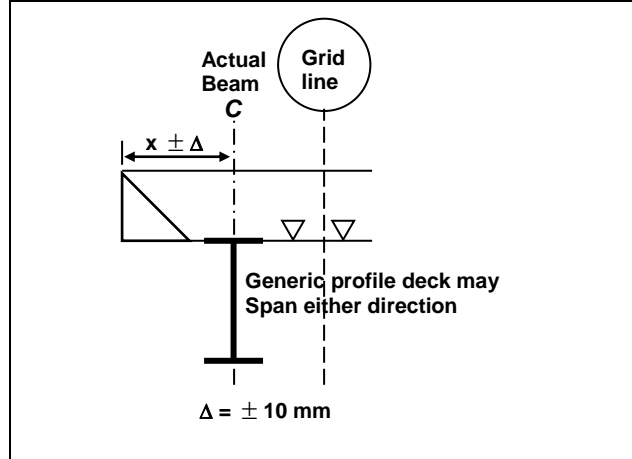

15.12.20 Thickness of bedding

The difference between the thickness of bedding and the specified nominal thickness shall be within one-third of the nominal thickness or 10mm, whichever is less.

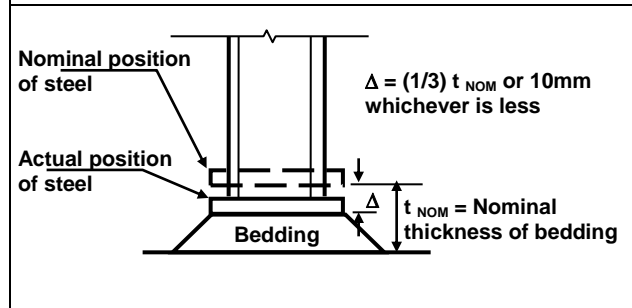

15.12.21 Position on bearing

The position of components supported on a bearing shall be within 5mm of the specified position relative to the bearing along both principal axes of the bearing.

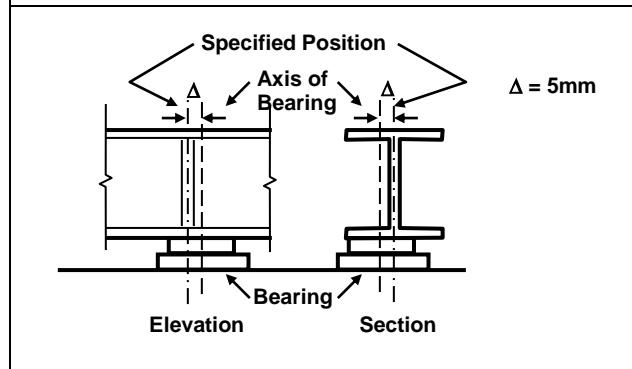

16 LOADING TESTS

16.1 GENERAL

16.1.1 Scope

Load tests may be used to establish the capacity of an existing structure or component or to verify design or construction that is not entirely in accordance with the design requirements of the Code.

Design may not be in accordance with the rest of the Code if sufficient and accurate calculations/models are not available or where the design loading capacity is to be established directly from knowledge of the failure capacity. However, testing must not be used to reduce levels of safety below those assumed in the remainder of the Code.

The loading tests described in this section are to verify or establish the design strength of a structure or component. They are proof, strength and failure tests. Tests may also be undertaken to establish design data to be used in a calculation model. These latter tests are not covered in detail in this section, and test plans must be established for each particular case taking into account the advice in this section.

Strength tests may be carried out on one or more prototypes where it is intended to construct a number of similar structures.

The tests described in this section are not applicable to the testing of scale models or of items subject to fluctuating loads where fatigue may govern the design.

For composite slabs with profiled steel sheets, both dynamic and static tests are required to demonstrate structural adequacy against shear-bond failure between the concrete and the profiled steel sheets. Refer to clause 16.4 for details of the test set-up, the testing procedures and the interpretation of the test results.

16.1.2 Requirement for testing

Where the structures and its parts have been designed in accordance with sections 1 to 13 of the Code, there is no requirement for testing.

16.1.3 Recommendations for conduct of tests

The following recommendations should be taken into account when deciding on a test and in the test preparation, execution and reporting.

Testing should only be carried out when the objectives have been clearly identified and there is sufficient confidence that they can be achieved. This should be based on calculation models and/or pilot tests. The objectives should include, where appropriate, the ability to incorporate the results in the design.

A test plan should be developed and should be agreed by all concerned before commencement of the test. The test plan should include the following as appropriate:

- (a) Aim of the test including the number of specimens.
- (b) Description of the test specimen/structural model together with the loading to be applied with particular attention to parameters and tolerances in dimensions and materials during fabrication and erection that might affect the performance.
- (c) Possible modes of failure.
- (d) Details of material and dimensional tests to be carried out on the specimens.
- (e) Testing arrangements including measures taken to ensure adequate strength and stiffness for any supporting rig as well as sufficient clearance to allow for deflections. This must take into account all possible failure mechanisms.
- (f) Details of loading and restraints and how the load will be controlled, i.e. either stress or strain control.
- (g) Details of what measurements are to be taken and frequency of measurements.
- (h) Accuracy of measurements.

The test plan should take into account the knowledge and experience of those carrying out the tests as well as the facilities and equipment being used.

When testing an existing structure a careful assessment of structural conditions before execution is a fundamental requirement. A support framework in proximity to the structure should be considered to avoid less than expected performance leading to failure.

16.2 PROOF, STRENGTH AND FAILURE TESTS

16.2.1 Proof and strength tests

16.2.1.1 General

Proof and strength tests are where the structure or component is tested to a particular level of load. A proof test may confirm that the structure performs adequately; a strength test may confirm that it can sustain a particular design load and can be used to accept similar items (see clause 16.3.6). A structure to be strength tested should first undergo a proof test and it is recommended that a failure test should follow the strength test, if appropriate.

Although a proof test is a non-destructive test, there may be permanent local distortions. The effect of these on future use of the structure should be considered before testing. Any departure from linear behaviour during the proof test should be noted and reasons for such behaviour should be explored. A strength test is likely to create significant residual deflection.

The loading steps for both tests are similar. To detect possible creep, the test load should be maintained at as constant value as possible to allow repeated measurements. The loads and deflections should be measured at regular intervals. The intervals should be at least 5 minutes. The loading should be maintained at the proof test load until there is no significant increase in deflection during at least three intervals after the attainment of the test load.

16.2.1.2 Test loads

The test load for a proof test should be taken as equal to the sum of:

- 1.0 x (actual dead load present during the test);
- and one of the following as appropriate:
 - a) 1.25 x (imposed load) plus 1.15 x (remainder of dead load);
 - b) 1.15 x (remainder of dead load) plus 1.2 x (wind load);
 - c) 1.2 x (wind uplift) minus 1.0 x (remainder of dead load);
 - d) 1.15 x (remainder of dead load) plus 1.0 x (imposed load and wind load).

The test load for a strength test is the factored design load (from section 4) multiplied by a relative strength coefficient (see Annex B).

16.2.1.3 Test criteria

The criteria for a successful proof test are:

- (a) Substantially linear behaviour under the proof test load;
- (b) No creep under the proof test load for a period of at least 15 minutes; and
- (c) On removal of the test load a residual deflection not exceeding 20% of the maximum deflection recorded during the test.

If the proof test is not successful it may be repeated once only. For this repeated test the deflection criteria is reduced to 10% of the maximum recorded during the test.

For a successful strength test the residual deflection on removal of the test load shall not exceed 80% of the maximum deflection recorded during the test and there is no buckling or rupture of any part of the structure.

16.2.2 Failure test

16.2.2.1 *General*

In a failure test the mode of failure and the ultimate load carrying capacity of a structure or component are to be determined. Gross permanent deformation is likely to occur during the test.

Before carrying out a failure test, a proof test and a strength test should be carried out. The loads for these tests will need to be based on estimates of the design capacity. This could then be adjusted following the strength test.

The loading in a failure test should initially be that of a strength test. After the strength test load has been reached subsequent increments should be based on an examination of a plot of the principal deflections.

The failure load is the maximum test load that the specimen can sustain.

The design capacity of an item similar to that being tested may be determined from the results of a failure test in accordance with the method given in Annex B of the Code.

16.2.2.2 *Failure criteria*

Failure of a test specimen should be considered to have occurred

- (a) if there is collapse or fracture;
- (b) if a crack begins to propagate spread in a vital part of the test specimen; or
- (c) if the displacement becomes grossly excessive.

16.3 TEST CONDITIONS, METHODS AND PROCEDURES

16.3.1 Test conditions

The test rig should have sufficient strength and stiffness so that the tests can simulate the behaviour of the structure or component in service. Adequate clearance should be provided for the expected deflections. Any restraint to deformation of the specimen provided by the rig should not be more than that which would be available in service.

The specimen, the loads and the restraints should be similar in all aspects to the structure or component that is to be represented. Loading devices should reproduce the magnitude and distribution of loads and avoid unintended eccentricities. Supports and restraints should represent the actual conditions in service.

Safety must be considered in the layout and design of the test. The test rig should be designed so that it remains stable even if there is failure of the test specimen.

16.3.2 Loading and unloading

Before the commencement of the test an initial load may be applied and removed to secure the test specimen onto the test rig. This should not exceed the unfactored value of the relevant loads.

The test loads must take into account the difference between the self-weight of the specimen and the actual dead load in service. When several loads are applied to the specimen, the load increments should be applied proportionally to each loading point.

There shall be at least five load increments in the test. The actual number should be such that there is a full record of the behaviour of the test specimen. They should be based on the expected load-deformation behaviour. The principal deflections should be monitored throughout the test and if they indicate significant non-linearity the load increments should be reduced. Unloading should be completed in regular decrements.

The rate of loading should be such that it can be considered to be quasi-static and after each load increment enough time must be allowed for the structure to reach stationary equilibrium.

Deflections and strains should be measured at each increment or decrement of the loading and after unloading is completed. Readings should not be taken until the

structure has completely stabilized. Where it is possible and safe, the structure should be examined after each load increment for signs of rupture, yielding or overall buckling.

16.3.3 Measurements

The anticipated magnitudes of the deflections should be estimated in advance, with generous allowances for movement beyond the elastic range. Sufficient measurement points should be used such that the maximum deflection of the test specimen can be determined.

16.3.4 Material properties

In order to use and compare the test results the properties of the steel used in the specimen should be established by means of coupon tests.

The coupons should be cut from the same sections or plates as the test specimens or recovered from unyielded areas of the test specimens after the completion of testing.

The yield strength and tensile strength of the steel should be determined by tensile testing in accordance with recognised standards.

A set of coupon tests should be taken from each component. The mean of each set may be taken as the material properties of the component.

Where material properties are required to determine the test load for a strength test or for other reasons, a single coupon test from each lot of material for the components of an individual test specimen may be used to obtain a weighted mean yield strength for the whole assembly.

16.3.5 Relative strength coefficient

Test results should be adjusted using a relative strength coefficient unless the design is based on the properties obtained from the test. This takes into account the effect of variations of the geometry or material properties of the test specimens, as compared with their nominal values. The coefficient should be used to predetermine the test load for strength tests and/or to determine the design capacity from a failure test. Annex B of the Code describes how the relative strength coefficient may be calculated for strength and failure tests.

16.3.6 Quality control of load testing

Components or parts of a structure can only be accepted on the basis of strength or failure tests if there is quality control during production to confirm consistency.

Unless justified by other means at least two samples should be selected at random from each production batch. Each batch should be taken as 20 tonne weight or less of the same section group with identical nominal serial size. Examination of the samples should establish that they are similar in all relevant respects to the prototype tested. Particular attention should be given to the dimensions of components and connections, to the tolerances and workmanship and to the quality of steel used (checked by reference to mill certificates).

If, after careful examination, the variations or the effect of variations compared to the prototype cannot be determined, a proof test should be carried out with measurements of deflections at the same positions as in the initial proof test on the prototype. The maximum measured deflection should not exceed 120 % of the deflection recorded during the proof test on the prototype and the residual deflection should not be more than 105 % of that recorded for the prototype.

16.3.7 Contents of test report

The test report should record the circumstances of the test and include all measurements and observations taken. The list below identifies possible items.

- (a) Circumstances of the test i.e. test plan, date, location, list of witnesses and attendees;

- (b) Qualifications and experience of test consultant and accreditation status such as a HOKLAS accredited laboratory;
- (c) Dimensions and arrangement of the test rig including the positions of loading points and measuring devices;
- (d) Actual dimensional measurements of the test specimen;
- (e) Details of the loading method and testing procedure;
- (f) All test results necessary for the test evaluation;
- (g) A record including data and photographs of all other observations from the test.

As far as is possible tested samples should be retained. If not, then photographs of the samples after testing should be kept.

16.4 TESTING OF COMPOSITE SLABS

For composite slabs with profiled steel sheets, it is essential to perform full-scale dynamic and static tests to demonstrate structural adequacy against shear-bond failure between the concrete and the profiled steel sheets.

16.4.1 General

The tests described in this section are of two types.

- (1) Specific tests
These are full-scale tests of a composite slab with a particular member configuration, using actual loading or a close approximation to it. The purpose is to determine the load carrying capacity of a slab directly by testing. The results obtained should be applied only to the particular case of span, profiled steel sheets and concrete grade and thickness tested.
- (2) Parametric tests
These are a series of full-scale tests of a proposed type of composite slab, over a range of parameters covering loading, profiled steel sheet thickness, concrete thickness and spans. The purpose of these tests is to obtain data to enable the values of the empirical parameters k_r and m_r to be established, which are then used to determine the shear-bond capacity V_s (see clause 10.4.5.3(2)a).

All testing should be carried out by established testing organizations with suitable qualifications and relevant experience such as a HOKLAS accredited laboratory or equivalent.

16.4.2 Specific tests

- (1) Test arrangement
A minimum of three full-scale tests should be carried out on representative samples of the proposed slab construction using actual loadings or, in the case of uniformly distributed loads, a close simulation of the loading as shown in Figure 16.1. In the case of continuous spans, the tests should either be on multiple spans or be on a single span with simulated support moments.

The width of the test slabs should not be less than the largest of the following:

- three times the overall depth, $3D_s$;
- 600 mm;
- the width of the profiled steel sheet.

Thin sheet steel crack inducers extending to the full depth of the slab and coated with a debonding agent should be placed across the full width of the test slab to ensure that the cracks form in the tensile zone of the slab. In the case of four-point loading, the crack inducers should be positioned under the two more central loads, as shown in Figure 16.1. For non-uniform or asymmetrical loading arrangements, the crack inducers should be positioned at the points of maximum bending moment.

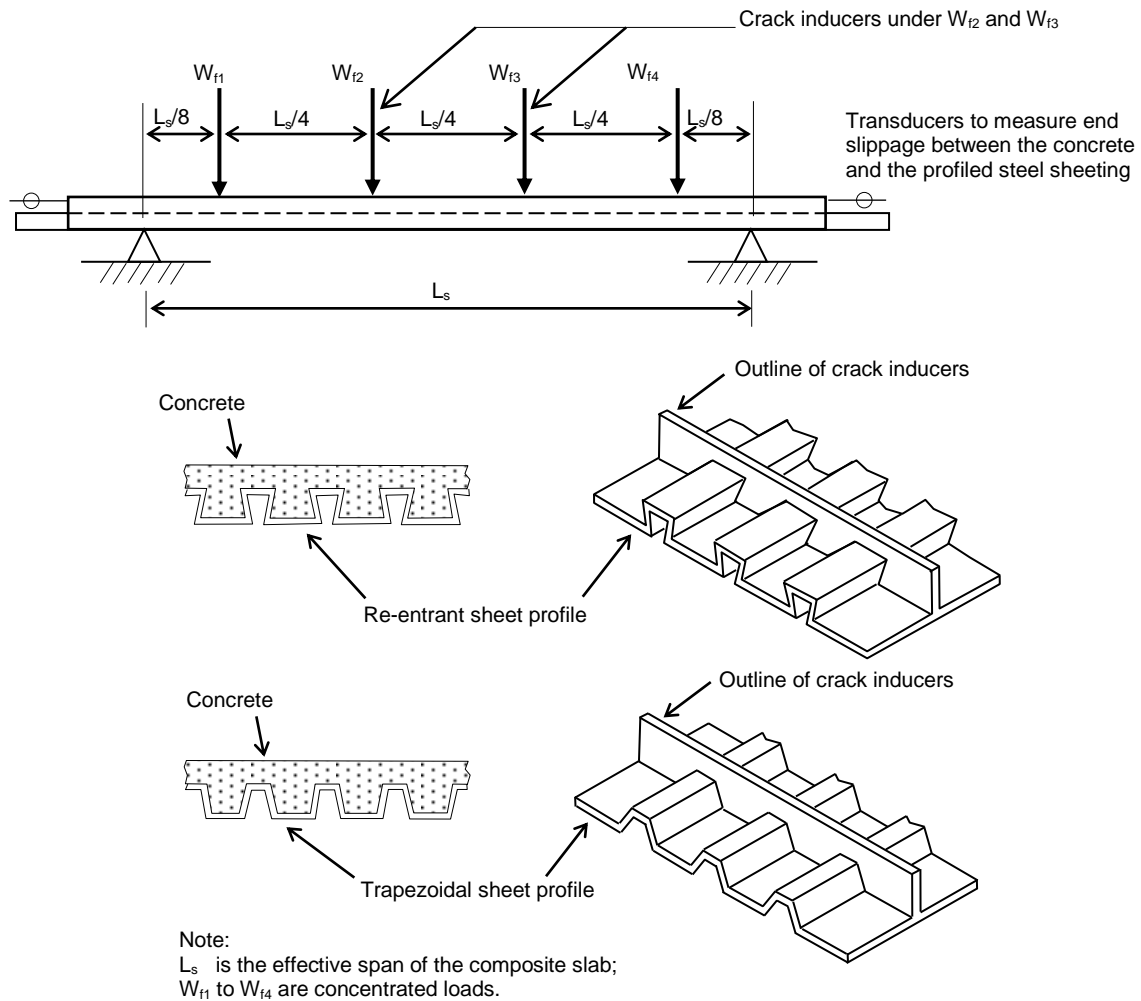

Figure 16.1 - Test details

The surface of the profiled steel sheets should be in the “as-rolled” condition, no attempt being made to improve the bond by degreasing the surface. A minimum of four concrete test cubes should be prepared at the time of casting the test slabs. The cubes should be cured under the same conditions as the slabs and tested at the time of loading the slab. The ultimate tensile strength and yield strength of the profiled steel sheets should be obtained from standard coupon test with test specimens cut from samples of each of the sheets used to form the composite test slabs.

(2) Test load procedure

a) General

The load carrying capacity of the proposed composite slab construction should be determined from tests representing the effects of loading applied over a period of time. The testing procedure should consist of the following two parts:

- an initial dynamic test in which the slab is subjected to a cyclic load;
- a static test in which the applied load is increased until the slab fails.

It is important to set up the target values of the applied loading capacities of the proposed composite slab construction, W_c , which is equal to the anticipated value of the applied load W_w (at $\gamma_f = 1.0$) excluding the weight of the composite slab.

- b) Initial dynamic tests
 A test slab representative of the proposed composite slab should first be subjected to an applied cyclic load which varies between a lower value not greater than $0.5 W_w$ and an upper value not less than $1.5 W_w$. This loading should be applied for 10000 cycles in a time of not less than $3h$. Both the mid-span deflection and the end slippage should be recorded at regular intervals during the test. The slab should be deemed to have satisfactorily completed this initial dynamic test if the maximum deflection does not exceed $L_s / 50$, where L_s is the effective span of the composite slab. The dynamic tests aim to destroy any chemical bond between the concrete and the profiled steel sheet for subsequent examination. Moreover, the shear bond capacity through the mechanical interlocking and friction will be fully mobilized.
- c) Static test
 After satisfactory completion of the initial dynamic test, the same slab should be subjected to a static test in which the applied load is increased progressively until failure occurs. The failure load applied to the test slab, the mid-span deflection and the load at which the mid-span deflection reaches $L_s / 50$ should be recorded.
- d) Applied loading capacity
 The loading capacity W_c (at $\gamma_f = 1.0$) for the load applied to the slab should, for design purposes, be taken as the lowest of the following:
- i) 0.75 of the average applied static load (for a minimum of three tests) at a deflection of $L_s / 50$, the slab not having failed;
 - ii) 0.5 of the average applied static load at failure W_{st} , when the slab fails with sudden and excessive end slip (i.e. when only partial horizontal shear connection is present between the concrete and the profiled steel sheets);
 - iii) 0.75 of the average applied static load at failure W_{st} , when the slab fails without sudden and excessive end slip (i.e. when full horizontal shear connection is present between the concrete and the profiled steel sheet);
 - iv) the upper value of the applied load used for the dynamic test.

If the applied load in the static test has reached twice of W_w but has not caused failure in the slab under i), ii) or iii), then the static test may be stopped, and both the dynamic and static tests may be repeated at higher values of W_w . Hence, the target values of the applied load capacity of the proposed composite slab construction will be increased accordingly.

- (3) Reporting of test results
 The following information should be included in the report for each slab tested:
- anticipated value of the applied load W_w (at $\gamma_f = 1.0$) for which the slab was tested;
 - thickness and overall depth of profiled steel sheets;
 - dimensions and spacing of shear transfer devices;
 - ultimate yield strength and tensile strength of profiled steel sheets;
 - dimensions of composite slab;
 - observed values of concrete cube strengths f_{cm} ;
 - load ranges during the dynamic test, e.g. $0.5 W_w$ to $1.5 W_w$;
 - load deflection and load end slippage graphs for both the dynamic test and the static test;
 - static load at failure W_{st} ;
 - mode of failure of composite slab (flexure, longitudinal slip or vertical shear) and type of failure (ductile or brittle);

- applied loading capacity W_c ;
- dead weight of composite slab;
- the total load carrying capacity of the slab (i.e. W_c plus dead weight of slab).

16.4.3 Parametric tests

(1) General

Separate series of tests should be carried out for different thicknesses, grades and types of profiled steel sheets and for different grades of concrete and slab thickness. The variable in a series of tests should be the shear span L_v (see clause 10.4.5.3(2b)).

The tests should encompass the full range of spans required for use in practice. No extrapolation should be made outside this range of spans.

Where shear studs are used to connect the composite slab to the supporting beams, these should be omitted from the test specimens. Their effects as end anchorages should then be covered separately (see clause 10.4.5.3(3)).

The mode of failure should be recorded, distinguishing between flexural failure, longitudinal slip and vertical shear failure. Relative movement (end slip) between the sheets and the concrete at the ends of the test slab should be considered as indicating longitudinal slip. The absence of end slip at failure should be considered as indicating flexural failure with full shear connection.

If the failure mode is vertical shear, the results should not be used for determining values of the empirical parameters m_r and k_r .

(2) Testing arrangement and procedure

At least two sets of slabs should be tested, each comprising not less than three samples. Testing should be carried out in accordance with clauses 16.4.2(1) & (2) while at least two sets of four concrete cubes will be required. The same nominal compressive cube strength grade of concrete should be used for all tests.

Both shape and the shear transfer device such as embossment of the profiled steel sheets should accurately represent those to be used in practice. Tolerances of 5% on spacing of embossments and 10% on size and depth of embossments should be applied as limits.

(3) Test results

To establish the design relationship for shear-bond capacity, tests should be carried out on specimens in regions A and B indicated in Figure 16.2. The maximum experimental shear force V_E should be taken as half of the value of the failure load W_{st} as defined in clause 16.4.2(2c) for each test. Only values from tests which resulted in shear-bond failure should be included.

The variables used for the tests should have values such that the parameters $V_E / (B_s d_s \sqrt{f_{cm}})$ and $A_p / (B_s L_v \sqrt{f_{cm}})$ for A and B regions:

- lie within the complete range of values for which a shear-bond type of failure is expected to occur; and
- encompass the actual range of values which are required for use in practice.

For specimens in region A the shear span should be as long as practicable, whilst still producing a shear-bond type of failure. For specimens in region B the shear span should be as short as practicable, whilst still producing a shear-bond type of failure. However, shear spans less than 450 mm should not be used.

The nominal shape and thickness of the profiled steel sheets used for the tests should be the same as those to be used in practice and the value of A_p should not vary by more than $\pm 10\%$ between the test specimens. The nominal strength grade of the profiled steel sheets should also be the same as that to be used in practice.

The minimum cube strength f_{cm} of the concrete for the specimens should not be less than 25 N/mm² and the variation between the mean cube strengths of the concrete for the specimens in regions A and B should preferably not exceed 5 N/mm². Where the variation is greater, the mean cube strength for all the specimens should be used when plotting the test results.

From the tests a regression line should be plotted as shown in Figure 16.2. The regression line should be taken as the best straight line between the test results in region A and those in region B.

There should be a minimum of three tests in each region, provided that the variation from the mean of the three results is not greater than $\pm 7.5\%$. When the variation is greater than $\pm 7.5\%$, three further tests should be carried out and the six test results should be used to obtain the regression line. In order that the experimental values will generally lie above the line used for design, the values of the empirical parameters m_r and k_r for use in design (see clause 10.4.5.3(2)a) should be determined on the basis of a reduction line, as indicated in Figure 16.2. Generally, the reduction line should be 15% below the regression line, except that, when eight or more tests are carried out, the reduction line should be taken as 10% below the regression line.

In the event that the value of the empirical parameter k_r from the reduction line is negative (see Figure 16.2b), the application of the test results to design should be restricted as described in clause 10.4.5.3(2a).

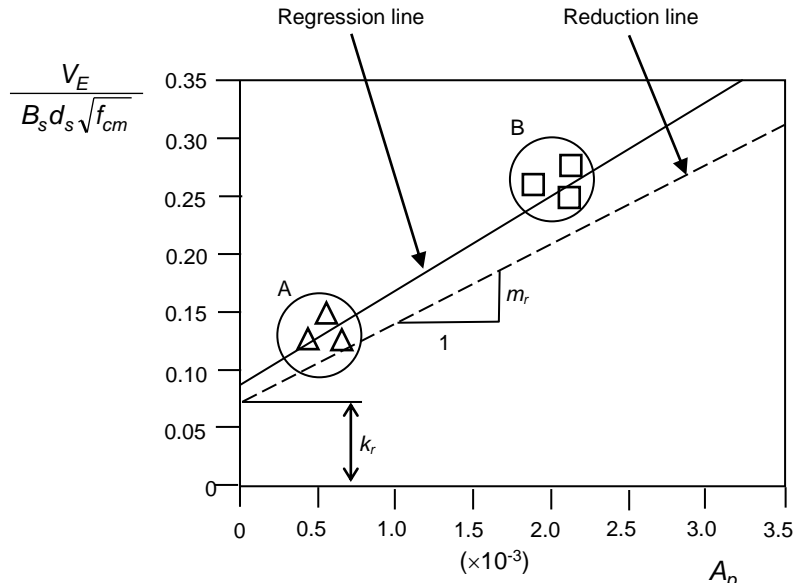

a) Positive value of k_r

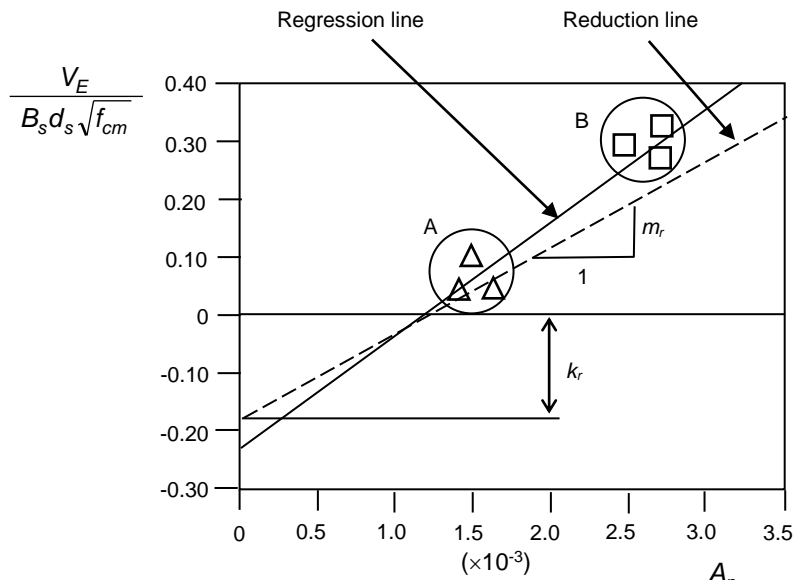

b) Negative value of k_r

Note:

A_p is the cross-sectional area of the profiled steel sheeting (in mm^2);

B_s is the width of the composite slab (in mm);

d_s is the effective depth of slab to the centroid of the profiled steel sheetings (in mm);

f_{cm} is the observed concrete cube strength (in N/mm^2);

k_r is an empirical parameter (in $\sqrt{\text{N/mm}^2}$);

L_v is the shear span of the composite slab (in mm), determined in accordance with clause 10.4.5.3(2);

m_r is an empirical parameter (in N/mm^2); and

V_E is the maximum experimental shear force (in N).

Figure 16.2 - Shear bond failure

17 GUIDANCE FOR EVALUATION AND MODIFICATION OF EXISTING STRUCTURES

17.1 GENERAL APPROACH

In all cases other than structural maintenance, the Responsible Engineer shall carry out an appraisal of the existing structure and foundations in order to:

- (a) Understand the structural system and load path, i.e. the way in which the building carries vertical and lateral loads to the ground. It is noted that the actual load paths may not be the same as those of the original design. Elements such as partition walls which were not considered by the original designer may actually carry loads and the appraising engineer must establish this. Alterations to the original construction may have been carried out.
Understand the current state of the structure, foundations and the materials forming it. Establish if there are any defects, if it has been damaged, if materials have deteriorated, and, if so, the extent of deterioration.
- (b) Assess the state of fire protection systems and corrosion protection systems.
- (c) Establish possible future additional loads which could be applied to the structure and establish suitable load paths for them.
- (d) Devise suitable details for connecting new structure to existing structure.
- (e) Devise any strengthening systems which may be necessary to enable the existing structure to carry different loads. The structural capacity of the members may be assessed using advanced design codes containing accurate methods.

Where suitable evidence is not available, the Responsible Engineer shall arrange for tests of original materials as necessary in order to establish design strengths in accordance with relevant standards and procedures.

In some situations, load tests of major components such as floor slabs may be necessary; however, results of such tests may be inconclusive or there may be a risk of damage. Therefore, such tests should be approached with caution.

The new structure, connections of new to existing and any necessary strengthening works shall be designed using established engineering principles and the requirements of the Code.

17.2 STRUCTURAL ASSESSMENT SURVEY

All possible evidence about the structure from various sources should be gathered and examined, as follows:

- (a) Existing drawings and documents. The best source of information is record drawings and specifications of the original design.
- (b) Historical studies and verbal information. Descriptions of older buildings of historical interest may be found in guidebooks, newspaper archives or historical studies. Useful information may be obtained from discussion with local people, for example village heads or archaeologists.
- (c) Structural survey. Having obtained information from initial desk studies, a site visit and structural survey should be carried out. Detailed guidance on carrying out structural surveys is given in the references in Annex A2.5.
- (d) Detailed site investigations, opening up of the superstructure and trial pits to examine foundations should be specified as necessary following the initial inspection.

17.2.1 Original materials

The materials used in the existing structure should be identified, initially from information on record drawings and by inspection. If material properties cannot be established to a reasonable level of accuracy, then it may be necessary to take samples for destructive

testing. The locations for taking samples must be carefully chosen to minimise damage, to avoid significant weakening of the parent structure and to provide sufficient and reliable data, particularly on chemical compositions and weldability of iron and steel. A better range of properties may be obtained from thicker sections where this is practical. Suitable methods of making good after taking samples shall be specified.

The references given in Annex A2.5 provide information on identifying old types of steel, wrought and cast iron.

17.2.2 Appraisal report

An appraisal report shall be prepared. It should describe the findings of the document studies, site surveys, material tests and any analysis and design check calculations carried out. Plain language and simple diagrams shall be used for the executive summary upon which decisions will be made. The report shall be written in a systematic way, see references in Annex A2.5 for detailed guidance on contents.

The appraisal report is a useful document in determining the probable scope of intended use or re-use of existing building.

17.3 DESIGN AND ANALYSIS ISSUES

17.3.1 Structural appraisal analysis and design check

If there is ongoing structural maintenance, i.e. restricted to repair and restoration of corroded or damaged members, a structural assessment should not normally be required.

In all other cases, as given in clause 17.1 a reasonable understanding of the structural system shall be established, including elements not formed part of the original structural design. This process requires forensic engineering intuition and experience.

More detailed discussion and guidance on this subject is given in the references listed in Annex A2.5.

Load factors and combinations used for the appraisal analysis should be taken from clause 4.3.3. In certain situations, there may be evidence to justify lower load factors.

Load factors and combinations for design of any new additions shall be taken from clause 4.3.1.

The possibility of fatigue loading on original elements should be considered.

17.3.2 Overall stability of existing and new structure

The structural appraisal must demonstrate that the existing structure, together with any additional structure, maintains an adequate factor of safety on overall stability against overturning or global buckling.

17.3.3 Details for connection of new to old structure

Suitable connection details shall be designed. Care shall be taken to ensure that existing structural elements are not unacceptably weakened by cutting, drilling or welding.

17.3.4 Upgrading of original structure

If it is necessary to strengthen the existing structure, then the design of suitable details to connect strengthening members to existing members shall allow for transfer of the required proportion of load into the new members.

A compatibility analysis should be carried out. Temperature effects should be considered.

It may be necessary to relieve dead and any other load on a member whilst it is being strengthened or repaired. This is especially important if heat from welding will be applied to existing members. The sequence of welding to enhance the strength should be

carefully specified to maintain symmetry of load effects and minimise distortion as far as possible.

Methods for transfer of load may include use of temporary jacks and brackets, use of permanent flat jacks or relief of load on existing structure by springing.

Surfaces of existing material which are to be strengthened or repaired shall be thoroughly cleaned to remove all foreign substance matters except surface protection in good condition. The parts of surfaces which are to be welded shall have all finishes removed for a clear distance of 50 mm from the proposed welds.

17.3.5 Considerations for design against extreme events (fire, accident, terrorism)

It may be difficult in practice or even economically not feasible to apply current standards on robustness or fire protection to older existing buildings. However, a suitable level of safety must be provided. Specific risk analysis and performance-based design may be required in order to justify an acceptable level of safety against fire and extreme events.

17.3.6 Serviceability issues

Similarly to clause 17.3.5, it may not be economically feasible to comply with current deflection or vibration guidelines. A performance-based justification of acceptable levels of deflection and vibration may be required.

17.4 LOAD TESTS

As stated in clause 17.1, load tests should be approached with caution. They should not be specified unless there is a reasonable expectation of success. If it is decided to carry out load tests, then the principles of such tests shall be in accordance with section 16 of the Code. However, in order to avoid damage, careful consideration shall be given to the magnitudes of the applied test loads.

To ensure the safety of test personnel and the public, the test arrangements shall be designed to fail safely in the event of failure of the element under test. References in Annex A2.3 provide further guidance on load tests.

ANNEX A REFERENCES

A1 ACCEPTABLE STANDARDS AND REFERENCES

This annex contains the standards considered acceptable to the Building Authority to be used together with the Code. Where it is intended to use other standards or technical references, or latest version of the standards given in Annex A, it should be demonstrated that they can achieve a performance equivalent to the acceptable standards as specified in the Code.

Future update of this list can be accessed in the Buildings Department's Homepage at "<http://www.bd.gov.hk>".

A1.1 Steel materials

A1.1.1 *Australian and New Zealand standards*

AS/NZS 1163: 2016	Cold-formed structural steel hollow sections
AS/NZS 1594: 2002 (R2016)	Hot-rolled steel flat products
AS/NZS 1595: 1998 (R2016)	Cold-rolled, unalloyed, steel sheet and strip
AS/NZS 3678: 2016	Structural steel - Hot-rolled plates, floorplates and slabs
AS/NZS 3679.1:2016	Structural steel - Hot-rolled bars and sections
AS/NZS 3679.2:2016	Structural steel - Welded I sections

A1.1.2 *American standards*

ASTM A36/A36M-19	Standard Specification for Carbon Structural Steel
ASTM A283/A283-18	Standard Specification for Low and Intermediate Tensile Strength Carbon Steel Plates
ASTM A308-2010	Standard Specification for Steel Sheet, Terne (Lead-Tin Alloy) Coated by the Hot-Dip Process
ASTM A423/A423M-19	Standard Specification for Seamless and Electric-Welded Low-Alloy Steel Tubes
ASTM A500/A500M-21a	Standard Specification for Cold-Formed Welded and Seamless Carbon Steel Structural Tubing in Rounds and Shapes
ASTM A514/A514M-18e1	Standard Specification for High-Yield-Strength, Quenched and Tempered Alloy Steel Plate, Suitable for Welding
ASTM A529/A529M-19	Standard Specification for High-Strength Carbon-Manganese Steel of Structural Quality
ASTM A572/A572M-21e1	Standard Specification for High-Strength Low-Alloy Columbium-Vanadium Structural Steel
ASTM A588/A588M-19	Standard Specification for High-Strength Low-Alloy Structural Steel, up to 50 ksi [345 MPa] Minimum Yield Point, with Atmospheric Corrosion Resistance
ASTM A595/A595M-18	Standard Specification for Steel Tubes, Low-Carbon or High-Strength Low-Alloy, Tapered for Structural Use
ASTM A618/A618M-21	Standard Specification for Hot-Formed Welded and Seamless High-Strength Low-Alloy Structural Tubing
ASTM A653/A653M-20	Standard Specification for Steel Sheet, Zinc-Coated (Galvanized) or Zinc-Iron Alloy-Coated (Galvannealed) by the Hot-Dip Process
ASTM A656/A656M-18	Standard Specification for Hot-Rolled Structural Steel, High-Strength Low-Alloy Plate with Improved Formability
ASTM A709/A709M-21	Standard Specification for Structural Steel for Bridges

ASTM A847/A847M-21	Standard Specification for Cold-Formed Welded and Seamless High Strength, Low-Alloy Structural Tubing with Improved Atmospheric Corrosion Resistance
ASTM A871/A871M-20	Standard Specification for High Strength Low-Alloy Structural Steel Plate with Atmospheric Corrosion Resistance
ASTM A875/A875M-21	Standard Specification for Steel Sheet, Zinc-5 % Aluminum Alloy-Coated by the Hot-Dip Process
ASTM A913/A913M-19	Standard Specification for High-Strength Low-Alloy Steel Shapes of Structural Quality, Produced by Quenching and Self-Tempering Process (QST)
ASTM A924/A924M-20	Standard Specification for General Requirements for Steel Sheet, Metallic-Coated by the Hot-Dip Process
ASTM A945–2006	Standard Specification for High-Strength Low-Alloy Structural Steel Plate with Low Carbon and Restricted Sulfur for Improved Weldability, Formability, and Toughness
ASTM A973/A973M-20	Standard Specification for Structural Steel Shapes
ASTM A992/A992M-20	Standard Specification for Structural Steel Shapes
ASTM A1011/A1011M-18a	Standard Specification for Steel, Sheet and Strip, Hot-Rolled, Carbon, Structural, High-Strength Low-Alloy, High-Strength Low-Alloy with Improved Formability, and Ultra-High Strength

A1.1.3 *Chinese standards*

GB/T 247 - 2008	Rules of acceptance, package, label and certification for plate, strip and wide flat in structural steel
GB/T 700 - 2006	Carbon structural steel
GB/T 709 - 2019	Dimension, appearance, weight and tolerance of plate, strip and wide flat in hot rolled structural steel
GB/T 1591 - 2018	High strength low alloy structural steel
GB/T 5313 - 2010	Steel plates with through-thickness characteristics
YB 4104 - 2000	Steel plate for high rise building structure
GB/T 16270 - 2009	High strength structural steel plates in the quenched and tempered condition
GB 50017 - 2017	Code for design of steel structures
GB 50205 - 2020	Standard for acceptance of construction quality of steel structures

A1.1.4 Japanese standards

JIS G 3101: 2020	Rolled steels for general structure
JIS G 3106: 2020	Rolled steels for welded structure
JIS G 3136: 2012	Rolled steels for building structure
JIS G 3350: 2021	Light gauge steels sections for general structure
JIS G 3352: 2014	Steel decks
JIS G 3444: 2021	Carbon steel tubes for general structure
JIS G 3466: 2021	Carbon steel square rectangular tubes for general structure
JIS A 5523:2021	Weldable hot rolled steel sheet piles
JIS A 5528:2021	Hot rolled steel sheet piles

A1.1.5 UK and European standards

BS EN 10025-1: 2019	Hot rolled products of non-alloy structural steels. Part 1: General technical delivery conditions
BS EN 10025-2: 2019	Hot rolled products of non-alloy structural steels. Part 2: Technical delivery conditions for non-alloy structural steels
BS EN 10025-3: 2019	Hot rolled products of non-alloy structural steels. Part 3: Technical delivery conditions for normalized/normalized rolled weldable fine grain structural steels
BS EN 10025-4: 2019	Hot rolled products of non-alloy structural steels. Part 4: Technical delivery conditions for thermomechanical rolled weldable fine grain structural steels
BS EN 10025-5: 2019	Hot rolled products of non-alloy structural steels. Part 5: Technical delivery conditions for structural steels with improved atmospheric corrosion resistance
BS EN 10025-6: 2019	Hot rolled products of non-alloy structural steels. Part 6: Technical delivery conditions for flat products of high yield strength structural steels in the quenched and tempered condition
BS EN 10164: 2018	Steel products with improved deformation properties perpendicular to the surface of the product - Technical delivery conditions.
BS EN 10210-1: 2006	Hot finished structural hollow sections of non-alloy and fine grain structural steels. Part 1: Technical delivery requirements.
BS EN 10210-2: 2019	Hot finished steel structural hollow sections. Tolerances, dimensions and sectional properties.
BS EN 10210-3: 2020	Hot finished steel structural hollow sections. Technical delivery conditions for high strength and weather resistant steels.
BS EN 10248-1: 1996	Hot rolled sheet piling of non alloy steels. Part 1: Technical delivery conditions
BS EN 10147: 2000	Continuous hot dip zinc coated carbon steel sheet of structural quality (withdrawn, and replaced by BS EN 10346:2015)
BS EN 10149-1: 2013	Hot rolled flat products made of high strength steels for cold forming – Part 1: General technical delivery conditions
BS EN 10149-2: 2013	Hot rolled flat products made of high strength steels for cold forming – Part 1: Technical delivery conditions for thermomechanically rolled steels

BS EN 10149-3: 2013	Hot rolled flat products made of high strength steels for cold forming – Part 1: Technical delivery conditions for normalized or normalized rolled steels
BS EN 10346: 2015	Continuously hot-dip coated steel flat products for cold forming.
BS EN 10219-1: 2006	Cold formed welded structural hollow sections of non-alloy and fine grain steels. Technical delivery requirements
BS EN 10219-2: 2019	Cold formed welded steel structural hollow sections. Tolerances, dimensions and sectional properties
BS EN 10219-3: 2020	Cold formed welded steel structural hollow sections. Technical delivery conditions for high strength and weather resistant steels

A1.1.6 Standards for destructive tests

BS EN ISO 148-1: 2016	Metallic materials - Charpy Pendulum impact test. Part 1: Test method
BS EN ISO 6892-1: 2019	Metallic materials - Tensile testing. Part 1: Method of test at ambient temperature
ASTM E8/E8M-21	Standard Test Methods for Tension Testing of Metallic Materials
ASTM E23-18	Standard Test Methods for Notched Bar Impact Testing of Metallic Materials
ASTM A770/A770M-03 (R2007)	Standard Specification for Through-Thickness Tension Testing of Steel Plates for Special Applications
JIS G 3199: 2021	Specification for through-thickness characteristics of steel plate, wide flat and sections
AS/NZS 3678: 2016	Structural steel – Hot-rolled plates, floorplates and slabs
GB 5313:2010	Steel plate with through-thickness characteristics

A1.2 Castings and forgings

A1.2.1 Australian standards

AS 2074: 2003	Cast steels
---------------	-------------

A1.2.2 American standards

ASTM A27/A27M-20	Standard Specification for Steel Castings, Carbon, for General Application
ASTM A148/A148M-20e1	Standard specification for steel castings, high strength, for structural purposes
ASTM A488/A488M -18e2	Standard Practice for Steel Castings, Welding Qualifications of Procedures and Personnel
ASTM A781/A781M -21	Standard Specification for Castings, Steel and Alloy, Common Requirements, for General Industrial Use
ASTM A957/A957M -21	Standard Specification for Investment Castings, Steel and Alloy, Common Requirements, for General Industrial Use

A1.2.3 Chinese standards

GB 50017 – 2017	Code for design of steel structures
-----------------	-------------------------------------

A1.2.4 Japanese standards

JIS G 3201: 1988	Carbon steel forgings for general use
JIS G 5101: 1991	Carbon steel castings
JIS G 5102: 1991	Steel castings for welded structure

JIS G 5111: 1991 High tensile strength carbon steel castings and low alloy steel castings for structural purposes

A1.2.5 *UK and European standards*

BS 29: 1976 Specification for carbon steel forgings above 150mm ruling section (Withdrawn in the UK, replaced by BS EN 10250-2: 2000)

BS 3100: 1991 Specification for steel castings for general engineering purposes (Withdrawn in the UK, replaced by BS EN 10293: 2005)

BS EN 10250-2: 2000 Open steel die forgings for general engineering purposes - Part 2: Non-alloy quality and special steels

BS EN 10293: 2015 Steel castings for general engineering uses

DIN 1681: 1990 Cast steel for general engineering purposes: technical delivery conditions

A1.3 Bolts

A1.3.1 *Australian and New Zealand standards*

AS 1110.1: 2015 ISO metric hexagon bolts and screws - Product grades A and B - Bolts

AS 1110.2: 2015 ISO metric hexagon bolts and screws - Product grades A and B - Screws

AS 1111.1: 2015 ISO metric hexagon bolts and screws - Product grade C - Bolts

AS 1111.2: 2015 ISO metric hexagon bolts and screws - Product grade C - Screws

AS 1112.1: 2015 ISO metric hexagon nuts - Style 1 - Product grades A and B

AS 1112.2: 2015 ISO metric hexagon nuts - Style 2 - Product grades A and B

AS 1112.3: 2015 ISO metric hexagon nuts - Product grade C

AS 1112.4: 2015 ISO metric hexagon nuts - Chamfered thin nuts - Product grades A and B

AS/NZS 1252: 2016 High strength steel bolts with associated nuts and washers for structural engineering

AS/NZS 1559: 2018 Hot-dip galvanized steel bolts with associated nuts and washers for tower construction

A1.3.2 *American standards*

ASTM A193-2014 Standard Specification for Alloy-steel and Stainless Steel Bolting Materials for High Temperature Service

ASTM A194/A194M-20a Standard Specification for Carbon Steel, Alloy Steel and Stainless Steel Nuts for Bolts for High Pressure or High Temperature, or Both

ASTM A307-21 Standard Specification for Carbon Steel Bolts and Studs, 60,000 PSI Tensile Strength

ASTM A325-2014 (withdrawn) Standard Specification for Structural Bolts, Steel, Heat Treated, 120/105 ksi Minimum Tensile Strength

ASTM A325M-2014 (withdrawn) Standard Specification for Structural Bolts, Steel, Heat Treated, 830 MPa Minimum Tensile Strength (Metric)

ASTM A490-14a (Withdrawn) Standard Specification for Structural Bolts, Alloy Steel, Heat Treated, 150 ksi Minimum Tensile Strength

ASTM A490M-14a (Withdrawn)	Standard Specification for High-Strength Steel Bolts, Classes 10.9 and 10.9.3, for Structural Steel Joints (Metric)
ASTM A563/A563M-21a	Standard Specification for Carbons and Alloy Steel Nuts
ASTM F436-19	Standard Specification for Hardened Steel Washers
ASTM F436M-19	Standard Specification for Hardened Steel Washers (Metric)
ASTM F1852-14 (Withdrawn)	Standard Specification for "Twist Off" Type Tension Control Structural Bolt/Nut/Washer Assemblies, Steel, Heat Treated, 120/105 ksi Minimum Tensile Strength
ASTM F3125/F3125M-21	Standard Specification for High Strength Structural Bolts and Assemblies, Steel and Alloy Steel, Heat Treated, Inch Dimensions 120ksi and 150 ksi Minimum Tensile Strength, and Metric Dimensions 830 MPa and 1040 MPa Minimum Tensile Strength
ASTM F3148-17a	Standard Specification for High Strength Structural Bolt Assemblies, Steel and Alloy Steel, Heat Treated, 144ksi Minimum Tensile Strength, Inch Dimensions

A1.3.3 *Chinese standards*

JGJ 82 - 1991	Bolts
GB 1228 - 2006	Form and Dimensions of high-strength large hexagonal bolts used in steel structures
GB 1229 - 2006	Form and Dimension of high-strength large hexagonal nuts used in steel structures
GB 1230 - 2006	Form and Dimensions of high-strength washers used in steel structures
GB 1231 - 1991	Technical Specifications for high-strength bolts, nuts and washers used in steel structures
GB 3098.1 - 2000	Mechanical properties of bolts for connection use
GB 3103.1 - 2001	Tolerance of bolt products
GB 3632 - 2008	Form and Dimensions of high-strength twist/shear type bolts used in steel structures
GB 3633 - 1983	Technical Specification for high-strength twist/shear type bolts used in steel structures
GB 50017 - 2003	Code for design of steel structures

A1.3.4 *Japanese standards*

JIS B 1051: 2000	Mechanical properties of fasteners made of carbon steel and alloy steel
JIS B 1180: 2004	Hexagon head bolts and hexagon head screws
JIS B 1181: 2004	Hexagon nuts and hexagon thin nuts
JIS B 1186: 1995/AMD1: 2007	Sets of high strength hexagon bolt, hexagon nut and plain washers for friction grip joints (Amendment 1)
JIS B 1256: 2008	Plain washers

A1.3.5 *UK, European and ISO standards*

BS 3692: 2014	ISO metric precision hexagon bolts, screws and nuts, Specification
BS 4190: 2014	ISO metric black hexagon bolts, screws and nuts, Specification
BS 4320: 1968	Specification for metal washers for general engineering purposes. Metric series (Withdrawn, and replaced by BS EN ISO 898-3:2018, BS EN ISO 7091:2000, BS EN ISO

	7092:2000, BS EN ISO 7093:2000, and BS EN ISO 7094:2000)
BS 4395-1: 1969	Specification for high strength friction grip bolts and associated nuts and washers for structural engineering - Part 1: General grade (Withdrawn, and replaced by BS EN 14399-1: 2015, BS EN 14399-2: 2015, BS EN 14399-3: 2015, BS EN 14399-4: 2015, BS EN 14399-5: 2015, BS EN 14399-6: 2015, BS EN 14399-7: 2018, and BS EN 14399-8: 2018)
BS 4395-2: 1969	Specification for high strength friction grip bolts and associated nuts and washers for structural engineering - Part 2: Higher grade bolts and nuts and general grade washers (Withdrawn, and replaced by BS EN 14399-1: 2005, BS EN 14399-2: 2015, BS EN 14399-3: 2015, BS EN 14399-4: 2015, BS EN 14399-5: 2015, BS EN 14399-6: 2015, BS EN 14399-7: 2018, and BS EN 14399-8: 2018)
BS 4604-1: 1970	Specification for the use of high strength friction grip bolts in structural steelwork - Metric series - Part 1: General grade (Withdrawn in the UK, replaced by BS EN 1993-1.8: 2005)
BS 4604-2: 1970	Specification for the use of high strength friction grip bolts in structural steelwork - Metric series - Part 2: Higher grade (parallel shank) (Withdrawn in the UK, replaced by BS EN 1993-1-8: 2005)
BS EN 1993-1-8: 2005	Eurocode 3 ; Design of steel structure. Design of joints
BS 4933: 2010	Specification for ISO metric black cup and countersunk head bolts and screws with hexagon nuts
BS 7419: 1991	Specification for holding down bolts
BS 7644-1: 1993	Direct tension indicators - Part 1: Specification for compressible washers (Replaced by BS EN 14399-9: 2009 but remains current)
BS 7644-2: 1993	Direct tension indicators - Part 2: Specification for nut face and bolt face washers (Replaced by BS EN 14399-9: 2009 but remains current)
BS EN 14399-1: 2015	High-strength structural bolting assemblies for preloading. General requirements
BS EN 14399-2: 2015	High-strength structural bolting assemblies for preloading. Suitability for preloading
BS EN 14399-3: 2015	High-strength structural bolting assemblies for preloading. System HR. Hexagon bolt and nut assemblies
BS EN 14399-4: 2015	High-strength structural bolting assemblies for preloading. System HV. Hexagon bolt and nut assemblies
BS EN 14399-5: 2015	High-strength structural bolting assemblies for preloading. Plain washers
BS EN 14399-6: 2015	High-strength structural bolting assemblies for preloading. Plain chamfered washers
BS EN 14399-7: 2018	High-strength structural bolting assemblies for preloading. System HR. Countersunk head bolt and nut assemblies
BS EN 14399-8: 2018	High-strength structural bolting assemblies for preloading. System HV. Hexagon fit bolt and nut assemblies
BS EN 14399-9: 2018	High strength structural bolting for preloading. System HR or HV. Part 9: Direct tension indicators for bolts and nuts assemblies

BS EN ISO 898-1:2013	Mechanical properties of fasteners made of carbon steel and alloy steel. Bolts, screws and studs with specified property classes. Coarse thread and fine pitch thread
BS EN ISO 898-2:2012	Mechanical properties of fasteners made of carbon steel and alloy steel. Nuts with specified property classes. Coarse thread and fine pitch thread
BS EN ISO 898-3:2018+A1:21	Fasteners. Mechanical properties of fasteners made of carbon steel and alloy steel. Flat washers with specified property classes View details
BS EN ISO 4014: 2011	Hexagon head bolts: Product grades A and B
BS EN ISO 4016: 2011	Hexagon head bolts: Product grade C
BS EN ISO 4017: 2011	Hexagon head screws: Product grades A and B
BS EN ISO 4018: 2011	Hexagon head screws: Product grade C
BS EN ISO 4032: 2001	Hexagon nuts, style 1: Product grades A and B
BS EN ISO 4033: 2001	Hexagon nuts, style 2: Product grades A and B
BS EN ISO 4034: 2001	Hexagon nuts: Product grade C
BS EN ISO 7091: 2000	Plain washers: Normal series, Product grade C

A1.4 Welding

A1.4.1 Welding Standards

A1.4.1.1 American standards

AWS D1.1/D1.1M: 2010	Structural Welding Code - Steel
AWS D1.3/D1.3M: 2008	Structural Welding Code - Sheet Steel
AWS A5.5/5.5M: 2014	Specification for Low-Alloy Steel Electrodes for Shielded Metal Arc Welding
AWS A5.23/5.23M: 2021	Specification for Low-Alloy and High Manganese Steel Electrodes and Fluxes for Submerged Arc Welding
AWS A5.28/A5.28M: 2005	Specification for Low-Alloy Steel Electrodes and Rods for Gas Shielded Arc Welding
AWS A5.29/A5.29M: 2010	Specification for Low-Alloy Steel Electrodes for Flux Cored Arc Welding

A1.4.1.2 UK European and ISO standards

BS EN 440: 1995	Welding consumables. Wire electrodes and deposits for gas shielded metal arc welding of non alloy and fine grain steels. Classification (Withdrawn in the UK, replaced by BS EN ISO 14341: 2011)
BS EN ISO 14341: 2011	Welding consumables. Wire electrodes and weld deposits for gas shielded metal arc welding of non alloy and fine grain steels. Classification
BS EN 499: 1995	Welding consumables. Covered electrodes for manual metal arc welding of non alloy and fine grain steels. Classification (Withdrawn in the UK, replaced by BS EN ISO 2560: 2009)
BS EN ISO 2560: 2009	Welding consumables. Covered electrodes for manual metal arc welding of non alloy and fine grain steels. Classification
BS EN 719: 1994	Welding coordination. Tasks and responsibilities (Withdrawn in the UK, replaced by BS EN ISO 14731: 2006)
BS EN ISO 14731: 2006	Welding coordination. Tasks and responsibilities
BS EN 729-2: 1995	Quality requirements for welding. Fusion welding of metallic materials. Part 2: Comprehensive quality requirements (Withdrawn in the UK, replaced by BS EN ISO 3834-2: 2005)
BS EN ISO 3834-2: 2005	Quality requirements for fusion welding of metallic materials. Part 2: Comprehensive quality requirements
BS EN 729-3: 1995	Quality requirements for welding. Fusion welding of metallic materials. Part 3: Standard quality requirements (Withdrawn in the UK, replaced by BS EN ISO 3834-3: 2005)
BS EN ISO 3834-3: 2005	Quality requirements for fusion welding of metallic materials. Part 3: Standard quality requirements
BS EN 729-4:1995	Quality requirements for welding. Fusion welding of metallic materials. Part 4: Elementary quality requirements (Withdrawn in the UK, replaced by BS EN ISO 3834-4: 2005)
BS EN ISO 3834-4: 2005	Quality requirements for fusion welding of metallic materials. Part 4: Elementary quality requirements

BS EN 756: 2004	Welding consumables. Solid wires, solid wire-flux and tubular cored electrode-flux combinations for submerged arc welding of non alloy and fine grain steels. Classification (Withdrawn in the UK, replaced by BS EN 14171: 2010)
BS EN 14171: 2010	Welding consumables. Solid wire electrodes, tubular cored electrodes and electrode/flux combinations for submerged arc welding of non alloy and fine grain steels. Classification
BS EN 758: 1997	Welding consumables. Tubular cored electrodes for metal arc welding with and without a gas shield of non-alloy and fine grain steels. Classification (Withdrawn in the UK, replaced by BS EN ISO 17632: 2008)
BS EN ISO 17632: 2008	Welding consumables. Tubular cored electrodes for gas shielded and non-gas shielded metal arc welding of non-alloy and fine grain steel. Classification
BS EN 1011-1: 2009	Welding - Recommendations for welding of metallic materials. Part 1: General guidance for arc welding
BS EN 1011-2: 2001	Welding - Recommendations for welding of metallic materials. Part 2: Arc welding of ferritic steels
BS EN 22553: 1995	Welded, brazed and soldered joints - Symbolic representation on drawings
BS EN ISO 14174: 2018	Welding consumables. Fluxes for submerged arc welding and electroslag welding. Classification.
BS EN ISO 18275: 2018	Welding consumables – Covered electrodes for manual metal arc welding of high-strength steels – Classification
BS EN ISO 18276: 2017	Welding consumables – Tubular cored electrodes for gas-shielded and non-gas-shielded metal arc welding of high-strength steels – Classification
BS EN ISO 16834: 2012	Welding consumables – Wire electrodes, wires, rods and deposits for gas shielded arc welding of high-strength steels – Classification
BS EN ISO 26304: 2018	Welding consumables - Solid wire electrodes, tubular cored electrodes and electrode-flux combinations for submerged arc welding of high strength steels - Classification (ISO 26304:2017)

A1.4.2 Welding Procedure Specification (WPS)

A1.4.2.1 American standards

AWS D1.1/D1.1M: 2010 Structural Welding Code - Steel

A1.4.2.2 UK European and ISO standards

BS EN 288-3: 1992	Specification and approval of welding procedures for metallic materials. Part 3: Welding procedure tests for the arc welding of steels (Withdrawn in the UK, replaced by BS EN ISO 15614-1: 2017+A1: 2019)
BS EN ISO 15607:2019	Specification and qualification of welding procedures for metallic materials – General rules
BS EN ISO 15609-1:2019(E)	Specification and qualification of welding procedures for metallic materials – Welding procedures specification – Part 1: Arc welding

BS EN ISO 15614-1: 2017 +A1: 2019	Specification and qualification of welding procedures for metallic materials - Welding procedure test - Part 1: Arc and gas welding of steels and arc welding of nickel and nickel alloys
BS EN ISO 15614-8:2016	Specification and qualification of welding procedures for metallic materials – Welding procedure test - Part 8: Welding of tubes to tube-plate joints

A1.4.3 Welder Qualification Tests

A1.4.3.1 American standards

AWS D1.1/D1.1M: 2010	Structural Welding Code - Steel
----------------------	---------------------------------

A1.4.3.2 UK European and ISO standards

BS EN 287-1: 2011	Qualification test of welders. Fusion welding. Part 1: Steels (Withdrawn, and replaced by BS EN ISO 9606-1:2017)
ISO 9606-1: 2017	Qualification testing of welders. Fusion welding. Steels
BS EN 1418:1998	Welding personnel. Approved testing of welding operators for fusion welding and resistance weld setters for fully mechanized and automatic welding of metallic materials (Withdrawn, and replaced by BS EN ISO 14732:2013)
BS 4871-3:1985	Specification for approval testing of welders to approved welding procedure. Part 3: Arc welding of tube to tube-plate joints in metallic materials
BS 4872-1:1982	Specification for approval testing of welders to welding procedure approval is not required. Part 1: Fusion welding of steel
BS EN 14732:2013	Welding personnel. Qualification testing of welding operators and weld setters for mechanized and automatic welding of metallic materials

A1.4.4 Non-Destructive Test Methods

A1.4.4.1 American standards

AWS D1.1/D1.1M: 2010	Structural Welding Code - Steel
----------------------	---------------------------------

A1.4.4.2 UK European and ISO standards

BS 3923: Part 1: 1986	Methods for ultrasonic examination of welds. Part 1: Methods for manual examination of fusion welds in ferritic steels (Withdrawn in the UK, replaced by BS EN 1714: 1998)
BS EN 1714: 1998	Non-destructive testing of welded joints. Ultrasonic examination of welded joints (Withdrawn in the UK, replaced by BS EN ISO 17640: 2018)
BS EN ISO 17640: 2018	Non-destructive testing of welds. Ultrasonic testing, Techniques, testing levels and assessment
BS EN 571-1: 1997	Non-destructive testing. Penetrant testing. Part 1: General principles (Withdrawn and replaced by BS EN ISO 34521-1:2021)
BS EN ISO 3452-1 :2021	Non-destructive testing. Penetrant testing. General principles
BS EN 970: 1997	Non-destructive examination of fusion welds. Visual examination (Withdrawn in the UK, replaced by BS EN ISO 17637: 2016)

BS EN 1290: 1998	Non-destructive examination of welds. Magnetic particle examination of welds (Withdrawn in the UK, replaced by BS EN ISO 17638: 2016)
BS EN ISO 17637: 2016	Non-destructive testing of welds. Visual testing of fusion welded joints
BS EN ISO 17638: 2016	Non-destructive testing of welds. Magnetic particle testing
BS EN ISO 17639: 2022	Destructive tests on welds in metallic materials. Macroscopic and microscopic examination of welds
BS EN 1435: 1997	Non-destructive examination of welds. Radiographic examination of welded joints (Withdrawn, and replaced by BS EN ISO 17636-1:2013, and BS EN ISO 17636-2:2013)
BS EN ISO 9934-1: 2016	Non-destructive testing. Magnetic particle testing. Part 1 : General Principles
BS EN ISO 17636-1:2013	Non-destructive testing of welds. Radiographic testing. X- and gamma-ray techniques with film
BS EN ISO 17636-2:2013	Non-destructive testing of welds. Radiographic testing. X- and gamma-ray techniques with film
BS EN ISO 10893-2:2011 + A1:2020	Non-destructive testing of steel tubes. Automated eddy current testing of seamless and welded (except submerged arc-welded) steel tubes for the detection of imperfections
BS EN ISO 10893-3:2011 + A1:2020	Non-destructive testing of steel tubes. Automated full peripheral flux leakage testing of seamless and welded (except submerged arc-welded) ferromagnetic steel tubes for the detection of longitudinal and/or transverse imperfections
BS EN ISO 10893-8:2011 + A1:2020	Non-destructive testing of steel tubes. Automated ultrasonic testing of seamless and welded steel tubes for the detection of laminar imperfections
BS EN ISO 10893-9:2011 + A1:2020	Non-destructive testing of steel tubes. Automated ultrasonic testing for the detection of laminar imperfections in strip/plate used for the manufacture of welded steel tubes
BS EN ISO 10893-10:2011 + A1:2020	Non-destructive testing of steel tubes. Automated full peripheral ultrasonic testing of seamless and welded (except submerged arc-welded) steel tubes for the detection of longitudinal and/or transverse imperfections

The abstracted essentials for typically used welding symbols are given in **Annex C**.

A1.4.5 *Destructive test methods for welds*

BS EN 875:1995	Destructive tests on welds in metallic materials. Impact tests. Test specimen location, notch orientation and examination (Withdrawn in the UK, replaced by BS EN ISO 9016: 2022)
BS EN ISO 9016: 2022	Destructive tests on welds in metallic materials. Impact tests. Test specimen location, notch orientation and examination
BS EN 876:1995	Destructive tests on welds in metallic materials. Longitudinal tensile tests on weld metal in fusion welded joints (Withdrawn in the UK, replaced by BS EN ISO 5178: 2019)
BS EN ISO 5178: 2019	Destructive tests on welds in metallic materials. Longitudinal tensile tests on weld metal in fusion welded joints

BS EN 895:1995	Destructive tests on welds in metallic materials. Transverse tensile test (Withdrawn in the UK, replaced by BS EN ISO 4136: 2022)
BS EN ISO 4136: 2022	Destructive tests on welds in metallic materials. Transverse tensile test
BS EN 910:1996	Destructive tests on welds in metallic materials. Bend tests (Withdrawn in the UK, replaced by BS EN ISO 5173: 2010)
BS EN ISO 5173: 2010	Destructive tests on welds in metallic materials. Bend tests
BS EN 1043-1:1996	Destructive tests on welds in metallic materials. Hardness testing hardness test on arc welded joints (Withdrawn in the UK, replaced by BS EN ISO 9015: 2016)
BS EN ISO 9015: 2016	Destructive tests on welds in metallic materials. Hardness testing hardness test on arc welded joints
BS EN 1320:1997	Destructive tests on welds in metallic materials. Fracture tests (Withdrawn and replaced by BS EN ISO 9017:2018)
BS EN 1321:1997	Destructive tests on welds in metallic materials. Macroscopic and microscopic examination of welds (Withdrawn and replaced by BS EN ISO 17639:2022)
BS EN ISO 9017:2018	Destructive tests on welds in metallic materials. Fracture test
BS EN ISO 17639:2022	Destructive tests on welds in metallic materials. Macroscopic and microscopic examination of welds
BS EN ISO 6505:1-3: 2005	Metallic materials. Brinell hardness test
BS EN ISO 6507:1-3: 2005	Metallic materials. Vickers hardness test

A1.5 Materials for composite design

Materials for composite design shall conform to the requirements of the Hong Kong Code of Practice for Structural Use of Concrete.

A1.6 Shear studs

A1.6.1 Australian standards

AS 1443: 2004	Carbon and carbon-manganese steel – Cold-finished bars
AS/NZS 1554.2: 2003	Structural steel welding - Stud welding (steel studs to steel)

A1.6.2 American standards

AWS D1.1/D1.1M: 2010	Structural Welding Code - Steel
----------------------	---------------------------------

A1.6.3 Chinese standards

GB 10433 - 2002	Shear studs
GB 50017 - 2003	Code for design of steel structures

A1.6.4 Japanese standards

JIS B 1198: 2011	Headed studs
------------------	--------------

A1.6.5 UK, European and ISO standards

BS EN ISO 13918: 2008	Welding. Studs and ceramic ferrules for arc stud welding
BS EN ISO 14555: 2006	Welding. Arc stud welding of metallic materials

A1.7 Cold-formed steel materials

A1.7.1 Australian and New Zealand standards

AS 1397: 2001	Steel sheet and strip - Hot-dipped zinc-coated or aluminium/zinc-coated
AS/NZS 1595: 1998	Cold-rolled, unalloyed, steel sheet and strip

A1.7.2 American standards

ASTM A308/A308M-10	Standard Specification for Steel Sheet, Terne (Lead-Tin Alloy) Coated by the Hot-Dip Process
ASTM A500/A500M-10a	Standard Specification for Cold-Formed Welded and Seamless Carbon Steel Structural Tubing in Rounds and Shapes
ASTM A653/A653M-10	Standard Specification for Steel Sheet, Zinc-Coated (Galvanized) or Zinc-Iron Alloy-Coated (Galvannealed) by the Hot-Dip Process
ASTM A792/A792M-10	Standard Specification for Steel Sheet, 55 % Aluminum-Zinc Alloy-Coated by the Hot-Dip Process

A1.7.3 Japanese standards

JIS G 3302: 2010	Hot-dip zinc-coated steel sheet and strip
JIS G 3312: 2008	Prepainted hot-dip zinc-coated steel sheet and strip
JIS G 3321: 2010	Hot-dip 55 % aluminium-zinc alloy-coated steel sheet and strip
JIS G 3322: 2008	Prepainted hot-dip 55 % aluminium-zinc alloy-coated steel sheet and strip
JIS G 3466: 2010	Carbon steel square and rectangular tubes for general structure

A1.7.4 Chinese standards

GB 50018 - 2002	Technical code of cold-formed thin-wall steel structure
-----------------	---

A1.7.5 UK, European and ISO standards

BS 5950-7: 1992	Structural use of steelwork in building. Specification for materials and workmanship: cold formed sections
BS EN 10149-1: 1996	Specification for hot-rolled flat products made of high yield strength steels for cold forming. Part 1: General delivery conditions
BS EN 10149-2: 1996	Specification for hot-rolled flat products made of high yield strength steels for cold forming. Part 2: Delivery conditions for thermomechanically rolled steels
BS EN 10149-3: 1996	Specification for hot-rolled flat products made of high yield strength steels for cold forming. Part 3: Delivery conditions for normalized or normalized rolled steels
BS EN 10219-1: 2006	Cold formed welded structural hollow sections of non-alloy and fine grain steels. Part 1: Technical delivery requirements
BS EN 10219-3: 2020	Cold formed welded structural hollow sections. Part 3: Technical delivery conditions for high strength and weather resistant steels
BS EN 10249-1: 1996	Cold formed sheet piling of non alloy steels. Part 1: Technical delivery conditions

BS EN 10268: 2006 Cold-rolled steel flat products with high yield strength for cold forming – Technical delivery conditions

A1.8 Dimensions and tolerances of sections

A1.8.1 Australian standards

AS/NZS 1163: 2009 Cold-formed structural steel hollow sections

A1.8.2 American standards

ASTM A6/A6M-11 Standard Specification for General Requirements for Rolled Structural Steel Bars, Plates, Shapes, and Sheet Piling

ASTM A500/A500M-10a Standard Specification for Cold-Formed Welded and Seamless Carbon Steel Structural Tubing in Rounds and Shapes

API 5L: 2007 Specification for Line Pipe

A1.8.3 Chinese standards

GB 50017 - 2003 Code for design of steel structures

GB 50205 - 2001 Code for acceptance of construction quality of steel structures

GB/T 702 - 2008 Hot-rolled round and square steels - Dimension, shape, weight and tolerance

GB/T 704 - 1988 Dimensions, shape, weight and tolerances for hot-rolled flats

GB/T 705 - 1989 Hot-rolled hexagonal and octagonal steel bars - Dimensions, shape, weight and tolerance

GB/T 706 - 2008 Hot-rolled beam steel - Dimensions, shape, weight and tolerances

GB/T 707 - 1988 Hot-rolled channel steel - Dimensions, shape, weight and tolerances

GB/T 708 - 2006 Dimensions, shape, weight and tolerances for cold-rolled plates and sheets

GB/T 709 - 2006 Dimension, appearance, weight and tolerance of plate, strip and wide flat in hot rolled structural steel

A1.8.4 Japanese standards

JIS G 3191: 2002/AMD1: 2010 Dimensions, mass and permissible variations of hot rolled steel bars in coil (Amendment 1)

JIS G 3192: 2008 Dimensions, mass and permissible variations of hot rolled steel sections

JIS G 3193: 2008 Dimensions, mass and permissible variations of hot rolled steel plates, sheets and strip

JIS G 3194: 1998 Dimensions, mass and permissible variations of hot rolled flat steel

A1.8.5 UK and European standards

BS 4-1: 2005 Structural Steel Sections. Part 1: Specification for hot-rolled sections

BS EN 10024: 1995 Hot-rolled taper flange I sections. Tolerances on shape and dimensions

BS EN 10029: 2010 Hot-rolled steel plates, 3mm thick or above. Tolerances on dimensions and shape

BS EN 10034: 1993	Structural steel I and H sections. Tolerances on shape and dimensions
BS EN 10055: 1996	Hot-rolled steel equal flange tees with radiused root and toes. Dimensions and tolerance on shape and dimensions
BS EN 10056-1: 1999	Specification for structural steel equal and unequal angles. Part 1: Dimensions
BS EN 10056-2: 1993	Specification for structural steel equal and unequal angles. Part 2: Tolerances on shape and dimensions
BS EN 10210-2: 2006	Hot finished structural hollow sections of non-alloy and fine grain structural steels. Part 2: Tolerances, dimensions and sectional properties
BS EN 10219-2: 2006	Cold formed welded structural hollow sections of non-alloy and fine grain steels. Part 2: Tolerances, dimensions and sectional properties
BS EN 10248-2: 1996	Hot rolled sheet piling of non alloy steels. Part 2: Tolerances on shape and dimensions
BS EN 10249-2: 1996	Cold formed sheet piling of non alloy steels. Part 2: Tolerances on shape and dimensions
BS EN 10279: 2000	Hot rolled steel channels. Tolerances on shape, dimensions and mass
EU 91	Hot-rolled wide flats: Tolerances on dimensions, shape and mass

A1.9 Protective treatment

A1.9.1 UK and European standards

BS 4652: 1995	Specification for zinc-rich priming paint (Organic media)
BS 4921: 1988	Specification for sherardized coatings on iron or steel
BS EN 22063: 1994	Metallic and other inorganic coatings. Thermal spraying. Zinc, aluminium and their alloys (Withdrawn in the UK, replaced by BS EN ISO 2063: 2005)
BS EN ISO 2063: 2005	Thermal spraying. Metallic and other inorganic coatings. Zinc, aluminium and their alloys
BS EN ISO 1461: 2009	Hot dip galvanized coatings on fabricated iron and steel articles. Specifications and test methods
BS EN ISO 11124-1:1997	Preparation of steel substrates before application of paints and related products. Specifications for metallic blast-cleaning abrasives. Part 1: General introduction and classification
BS EN ISO 11124-2: 1997	Preparation of steel substrates before application of paints and related products. Specifications for metallic blast-cleaning abrasives. Part 2 : Chilled-iron grit
BS EN ISO 11124-3: 1997	Preparation of steel substrates before application of paints and related products. Specifications for metallic blast-cleaning abrasives. Part 3 : High-carbon cast-steel shot and grit
BS EN ISO 11124-4:1997	Preparation of steel substrates before application of paints and related products. Specifications for metallic blast-cleaning abrasives. Part 4 : Low carbon cast-steel shot

A1.10 Other acceptable references

BS 2573-1: 1983	Rules for the design of cranes - Part 1: Specification for classification, stress calculations and design criteria for structures
BS 2853: 1957	Specification for the design and testing of steel overhead runway beams
BS 7608: 1993	Code of practice for fatigue design and assessment of steel structures (Withdrawn in the UK, replaced by BS EN 1993-1-9: 2005)
BS 7910: 2005	Guide on methods for assessing the acceptability of flaws in metallic structures
BS EN 1993-1-9: 2005	Eurocode 3: Design of Steel structures. Fatigue
Code of Practice on Wind Effects in Hong Kong	
Code of Practice for Structural Use of Concrete	
Code of Practice for Precast Concrete Construction	
Code of Practice for Fire Resisting Construction 1996	

A2 INFORMATIVE REFERENCES

A2.1 Practice Notes for Authorized Persons and Registered Structural Engineers

The following Practice Notes for Authorized Persons and Registered Structural Engineers provide useful guidance on steel design and construction:

PNAP APP-8	Chimneys and Flues
PNAP APP-48	Requirements for Qualified Supervision of Structural Works, Foundation Works and Excavation Works – Buildings Ordinance section 17
PNAP APP-53	Building (Construction) Regulations
PNAP ADM-13	Monitoring for Site Safety and Quality
PNAP APP-80	Code of Practice for Fire Resisting Construction 1996
PNAP APP-85	Application of the Revised Fire Safety Code
PNAP APP-87	Guide to Fire Engineering Approach
PNAP APP-102	Superstructure Works Measures for Public Safety
PNAP APP-118	Testing of Building Materials

A2.2 The Steel Construction Institute, UK

SCI Design Guides

SCI P-055: 1989	Design of composite slabs and beams with steel decking
SCI P-078: 1990	Commentary on BS5950: Part 3: Section 3.1 “Composite beams”
SCI P-142: 1994	Composite column design to Eurocode 4
SCI P-172: 1996	Castings in construction
SCI P-276: 2002	Building design using cold-formed steel sections: Structural design to BS5950: Part 5: 1998 - Section properties and load tables

Joint SCI & BCSA Publications

Joints in steel construction: 1995 – Moment connections

A2.3 UK and European Standards

BS 5950: Structural use of steelwork in building:

Part 1: 2000	Code of practice for design - Rolled and welded sections (Withdrawn in the UK, replaced by group of BS EN 1993-1-1: 2005, BS EN 1993-1-5: 2006, BS EN 1993-1-10: 2005, BS EN 1993-5: 2007, BS EN 1993-6: 2007 & BS EN 1993-1-8: 2005)
Part 2: 2001	Specification for materials, fabrication and erection - Rolled and welded sections (Withdrawn in the UK, replaced by BS EN 1090-2: 2008)
Part 3: 1990	Design in composite construction - Code of practice for design of simple and continuous composite beams (Withdrawn in the UK, replaced by BS EN 1994-1-1: 2004)
Part 4: 1994	Code of practice for design of composite slabs with profiled steel sheeting (Withdrawn in the UK, replaced by BS EN 1994-1-1: 2004)
Part 5: 1998	Code of practice for design of cold formed thin gauge sections (Withdrawn in the UK, replaced by BS EN 1993-1-3: 2006)
Part 6: 1995	Code of practice for design of light gauge profiled steel sheeting (Withdrawn in the UK, replaced by BS EN 1993-1-3: 2006)
Part 7: 1992	Specification for materials and workmanship: cold formed sections
Part 8: 2003	Code of practice for fire resistant design (Withdrawn in the UK, replaced by BS EN 1993-1-2: 2005)
BS 499-2c: 1999	Welding terms and symbols. Part 2c : European arc welding symbols in chart form
BS 5427-1: 1996	Code of practice for the use of profiled sheet for roof and wall cladding on buildings. Part 1: Design
BS 7608: 1993	Code of Practice for Fatigue Design and Assessment of Structures
BS EN 1090-1: 2009+A1:2011	Execution of steel structures and aluminium structures. Part 1: Requirements for conformity assessment of structural components
BS EN 1090-2: 2008	Execution of steel structures and aluminium structures. Part 2 : Technical requirements for the execution of steel structures
BS EN 1991-2: 2003	Eurocode 1: Actions on structures. Part 2: Traffic loads on bridges
BS EN 1993-1-1: 2005	Eurocode 3: Design of steel structures. Part 1-1: General rules and rules for buildings
BS EN 1993-1-2: 2005	Eurocode 3: Design of steel structures. Part 1-2 : General rules. Structural fire design
BS EN 1993-1-3: 2006	Eurocode 3: Design of steel structures. General rules Part 1-3 : Supplementary rules for cold-formed members and sheeting
BS EN 1993-1-5: 2006	Eurocode 3: Design of steel structures. Part 1-5 : Plated structural elements

BS EN 1993-1-8: 2005	Eurocode 3: Design of steel structures. Part 1-8 : Design of joints
BS EN 1993-1-10: 2005	Eurocode 3: Design of steel structure. Part 1-10 : Material toughness and through-thickness properties
BS EN 1993-5: 2007	Eurocode 3: Design of steel structures. Part 5 : Piling
BS EN 1993-6: 2007	Eurocode 3: Design of steel structures. Part 6 : Crane supporting structures
BS EN 1994-1-1: 2004	Eurocode 4: Design of composite steel and concrete structures. Part 1-1: General rules and rules for buildings
NA to BS EN 1991-2: 2003	UK National Annex to Eurocode 1: Actions on structures. Part 2: Traffic loads on bridges
PD 6688-2: 2011	Published Document – Background to the National Annex to BS EN 1991-2. Part 2 : Traffic loads on bridges

A2.4 Australian Standards

AS 4100: 1998	Steel structures
---------------	------------------

A2.5 General references

Appraisal of Existing Iron and Steel Structures

written by Michael Bussell, published by the Steel Construction Institute (1997).

Appraisal of Existing Structures

a guide published by the Institution of Structural Engineers, U.K.

Comité International pour le Développement et l'Étude de la Construction Tubulaire (CIDECT)

Design of Floors for Vibration: A New Approach

(Ascot: Steel Construction Institute) by Smith, A.L., Hicks, S.J. and Devine, P.J. (2007).

Fire-Resistance Tests – Elements of Building Construction

ISO-834, International Organization for Standardization.

Floor Vibrations due to Human Activity

written by T. M. Murray, D. E. Allen and E. E. Ungar, published by the American Institute of Steel Construction (1997).

Floor Vibration Induced by Dance-Type Loads: Theory

The Structural Engineer, Vol. 72 No.3, 1 February 1994, incorporated in BRE Digest 426 (2004).

Floor Vibration Induced by Dance-Type Loads: Verification

The Structural Engineer, Vol. 72 No.3, 1 February 1994, incorporated in BRE Digest 426 (2004).

Limit States Design of Steel Structures

CAN/CSA-S16.1-94, a National Standard of Canada published by Canadian Standard Association.

Response of Structures Subject to Dynamic Crowd Loads

(London: BRE Centre for Structural Engineering, 2nd edition) by Ellis, B.R. and Ji, T. (2004).

Steel Design Guide Series 11: Floor Vibrations due to Human Activity

by Murray et al, with Revisions and Errata List included.

ANNEX B RELATIVE STRENGTH COEFFICIENT

B1 GENERAL

This Annex B describes how to calculate the relative strength coefficient as referred in clause 16.3.5 of the Code.

Unless the design is based on the properties obtained from the test, test results should be adjusted using a relative strength coefficient. This takes into account the effect of variations of the geometry or material properties of the test specimens, as compared with their nominal values. The coefficient should be used to predetermine the test load for strength tests and/or to determine the design capacity from a failure test.

B2 PREDETERMINATION OF THE TEST LOAD FOR A STRENGTH TEST

Provided that the actual cross-sectional dimensions of the components do not exceed their nominal dimensions, the relative strength coefficient R_s may be obtained from:

$$R_s = \frac{\text{Weighted mean yield strength}}{\text{Nominal yield strength}}$$

The relative strength coefficient for an assembly of structural components should be based on the weighted mean value of the actual yield strength of each component. The weighting should take into account the contribution of each component to the expected performance of the test specimen. Unless other information is available, the contribution may be based on monitoring of the preliminary proof test.

If the actual cross-sectional dimensions exceed the nominal dimensions, the relative strength coefficient R_s should be obtained by making appropriate adjustments to the weighted mean yield strength, to allow for the influence of each cross-sectional dimension of the test specimen on its expected performance.

If there have been other similar tests that provide reliable information about the expected failure mode, the relative strength coefficient R_s may be determined as for a failure test, see clause 16.4.3 of the Code.

B3 PROCESSING THE RESULTS OF A FAILURE TEST

The relative strength coefficient should be used to determine the design capacity from the results of a failure test.

If a reasonable estimate of the capacity can be made by calculation using the Code or other proven methods of calculation that take into account all stability effects, the relative strength coefficient R_s may be obtained from:

$$R_s = \frac{\text{Capacity assessed using actual yield strength and actual dimensions}}{\text{Capacity assessed using nominal yield strength and nominal dimensions}}$$

If this is not possible, the relative strength coefficient R_s should be determined according to the observed failure mode, as follows:

a) for a ductile yielding failure:

$$R_s = \frac{\text{Mean yield strength}}{\text{Nominal yield strength}} \times R_p$$

in which the mean yield strength relates to the cross-section at which failure is observed;

b) for a sudden failure due to rupture in tension or shear:

$$R_s = \frac{\text{Mean ultimate tensile strength}}{\text{Nominal yield strength}} \times R_p$$

in which the mean tensile strength relates to the cross-section at which failure is observed;

c) for a sudden failure due to buckling:

$$R_s = \frac{1.2 \times \text{mean yield strength}}{\text{Nominal yield strength}} \times R_p$$

in which the mean yield strength relates to the cross-section at which failure is observed;

d) for a ductile failure due to overall member buckling:

$$R_s = \frac{\text{Buckling strength for mean yield strength}}{\text{Buckling strength for nominal yield strength}} \times R_p$$

in which the buckling strength relates to the relevant slenderness L/r from the appropriate buckling curve and the mean yield strength relates to the cross-section at which failure is observed; alternatively, R_s may be obtained as in a) if the relevant slenderness or the appropriate buckling curve are in doubt;

e) for a ductile failure due to local buckling of a flat element:

$$R_s = \frac{\text{Actual yield strength}}{\text{Nominal yield strength}} \times \frac{\text{Actual thickness}}{\text{Nominal thickness}} \times R_p$$

$$\text{but } R_s \geq \left[\frac{\text{Actual yield strength}}{\text{Nominal yield strength}} \right]^{-0.5} \times \left[\frac{\text{Actual thickness}}{\text{Nominal thickness}} \right]^2 \times R_p$$

and $R_s \geq 1$

where

$$R_p = \frac{\text{Actual value of section property}}{\text{Nominal value of section property}} \quad \text{but } R_p \geq 1$$

in which the section property is that relevant to resisting the observed failure mode, and the values relate to the cross-section at which failure is observed.

ANNEX C TYPICAL WELDING SYMBOLS

This annex contains typical welding symbols used.

1. ELEMENTARY SYMBOLS		
Type of weld	Illustration	Symbol
Butt weld between plates with raised edges which are melted down completely		
Square butt weld		
Single-V butt weld		
Single bevel butt weld		
Single-U butt weld		
Single-J butt weld		
Backing run		
Double-V butt weld		
Double bevel butt weld		
Double-U butt weld		
Fillet weld		
Plug weld (Plug or slot weld – USA)		
Surfacing		

2. SUPPLEMENTARY SYMBOLS		
Shape of weld surface or weld	Supplementary symbol	
Flat (usually finished flush by grinding and machining)		
Convex		
Concave		
Toes shall be blended smoothly – may require dressing		
Permanent backing strip used		
Removable backing strip used		
Examples of the use of supplementary symbols		
Designation	Illustration	Symbol
Flat (flush) single-V butt weld with permanent strip		
Flat (flush) single-V butt weld with flat (flush) backing run		
Convex double-v weld		
Concave fillet weld		
Fillet weld with * smoothly blended		

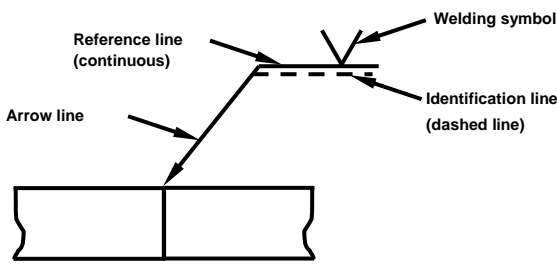
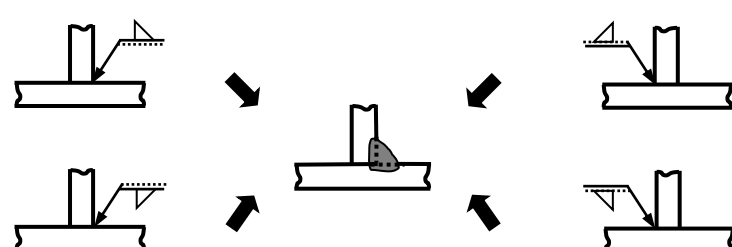
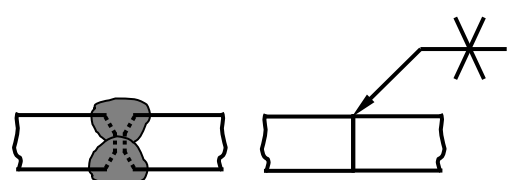
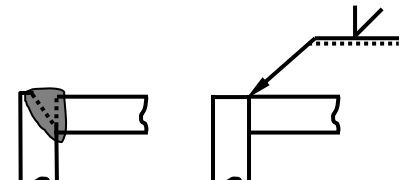
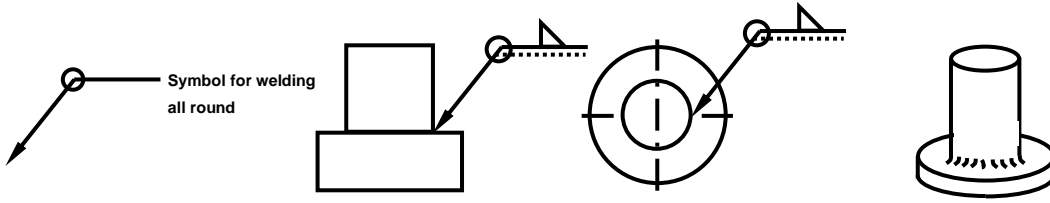
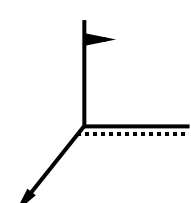
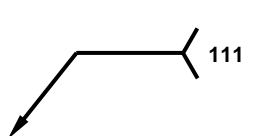
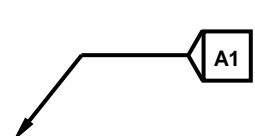
3. REFERENCE LINES AND OTHER INFORMATION		
<p>Method of representation</p> <p>The arrow may be used to indicate a welded joint on an elevation or cross section</p> 		
<p>Location of welding symbol on reference line</p> <p>It is recommended that the arrow line is placed on the side of joint to be welded unless there is not enough space.</p> <p>It is recommended that the welding symbol is placed on reference line but this is not mandatory.</p> 		
<p>Special rules for butt welds</p> <p>For symmetrical welds the identification line (dashed) is omitted.</p>  <p>For single J and bevel butt welds, the arrow points to the prepared edge.</p> 		
<p>Other information</p> <p>Welding all round</p> 		
<p>Site welding</p> 	<p>Welding process</p>  <p>e.g. 111=MIG, 131=MMA (in accordance with BS EN 24063)</p>	<p>Specific instructions</p>  <p>e.g. procedure sheet A1</p>

4. WELD DIMENSIONS

Butt welds

's' = minimum specified throat (penetration) thickness. If no dimension is shown, the weld is full penetration.

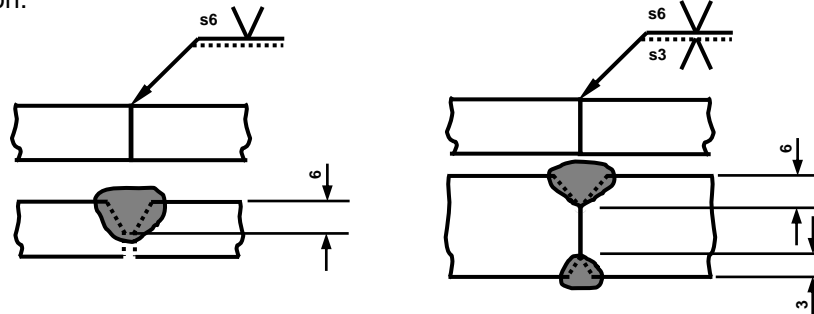

Fillet welds

'a' = throat thickness

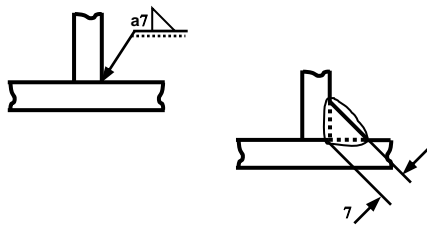

'z' = leg length

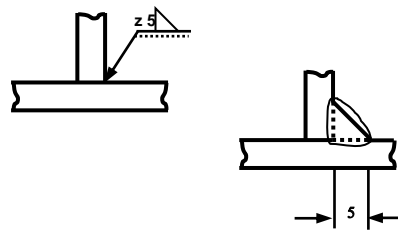

Deep penetration fillet welds

The throat thickness is designated by 's' and dimensions are given for example 's8a6'.

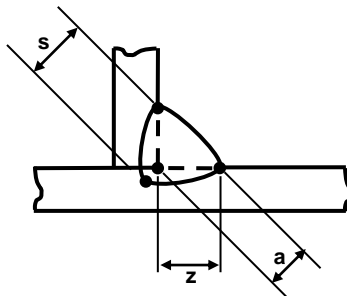





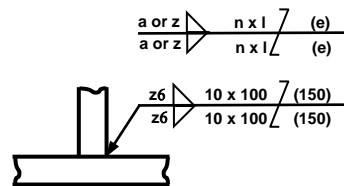
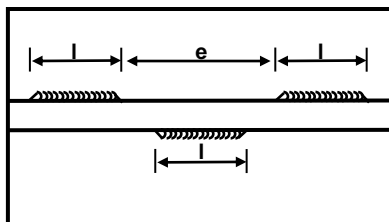





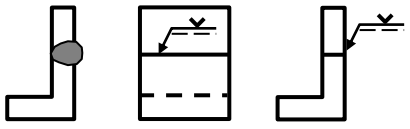

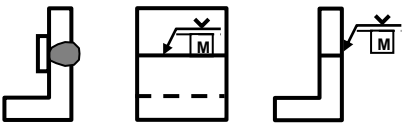
Weld length

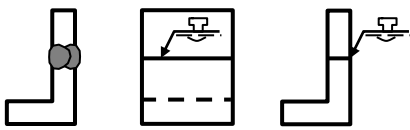
For continuous welds the length of weld is given to the right of the welding symbol
For intermittent welds, l=weld length, e=distance between welds, n=number of welds

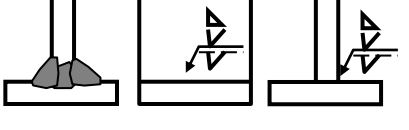
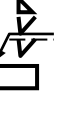
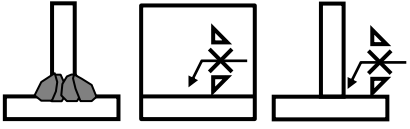

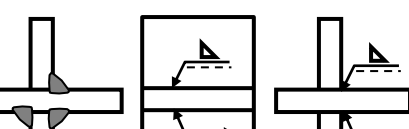
e.g. 10 staggered welds per side, leg length 6 mm, 100 mm long and 150 mm apart

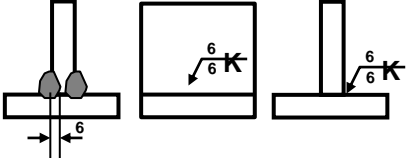
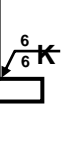
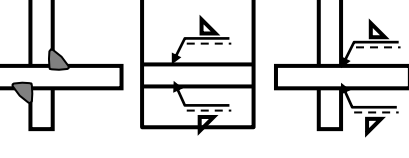
5. EXAMPLES SHOWING THE USE OF SYMBOLS

Description	Illustration	Symbol	Description	Illustration	Symbol
Single V-butt weld			Single V-butt weld with permanent backing strip		
Single V-butt weld with backing run			Single bevel T-butt weld with reinforcing fillets		
Double bevel T-butt weld with reinforcing fillets			Cruciform joint fillet welded on three sides		
Partial penetration T-butt weld (6mm penetration both sides)			Cruciform joint fillet welded on opposite sides		

ANNEX D **NOTES ON TESTING TO ESTABLISH STEEL CLASS AND ESSENTIALS OF SOME PRODUCT STANDARDS**

D1 TESTING TO ESTABLISH STEEL CLASS

Class 1 steel and Class 1H steel:

No additional testing is needed as these steels comply with one of the reference material standards in Annex A1.1 and the basic requirements given in clause 3.1.2, and the steels are produced from a manufacturer with an acceptable Quality Assurance system.

Class 2 steel:

Where steels are not supplied in accordance with one of the recognized reference material standards in Annex A1.1 but are produced from a manufacturer with an acceptable Quality Assurance system, such steels shall be tested to show that they comply with one of the reference material standards in Annex A1.1.

Tests shall include tensile strength and ductility, notch toughness and chemical compositions.

At a minimum one test in each category shall be made for every 20 tonnes of steels or part thereof the same product form, of the same range of sizes and thicknesses, and of the same cast.

The results of each test and the characteristic value obtained by statistical analysis shall not be less than the value required by the standard.

Class 3 steel:

Uncertified steels shall be tested for tensile strength and ductility to demonstrate that they have a yield strength of at least 170N/mm², an elongation of at least 15% and a tensile strength of at least 300N/mm². One test in each category shall be made for every 20 tonnes of steels or part thereof the same product form, of the same range of sizes and thicknesses. If the steels are to be welded, the Responsible Engineer may additionally require tests for weldability as described in Annex D1.1.

Quality control of testing

The testing shall be carried out to meet the reference material standards listed in Annex A1.1 by a HOKLAS accredited laboratory or by other laboratory accreditation bodies which have reached mutual recognition agreements/arrangements with HOKLAS.

D1.1 Essential requirements

The basic requirements for structural steels are:

- **Strength**
- **Resistance to brittle fracture**
- **Ductility**
- **Weldability**

Table D1a lists the essential performance requirements for typical hot rolled sections and plates, and hot finished and cold formed structural hollow sections, and Table D1b lists the essential performance requirements for typical cold formed thin gauge steel.

Table D1a - Essential performance requirements for hot rolled and hot finished structural steel and cold formed steel

Performance requirement	Specified by	Additional requirements for steel in structures designed by the plastic theory
Minimum yield strength	Smaller of yield strength (R_{eH}), 0.2% proof strength ($R_{p 0.2}$) and stress at 0.5% total elongation ($R_{t 0.5}$)	$R_m/R_{eH} \geq 1.2$ (1.2 is a minimum and a higher value may be required)
Minimum tensile strength	Tensile strength (R_m)	
Notch toughness	Minimum average Charpy V-notch impact test energy at specified temperature	None
Ductility	Elongation in a specified gauge length Bend test	Stress-strain diagram to have a plateau at yield stress extending for at least six times the yield strain. The elongation refers to Clause 3.1.2
Weldability	Maximum carbon equivalent value, Carbon content, Sulphur and Phosphorus contents	None
Through thickness properties (only for certain situations, see 3.1.5 and 14.3.3.4)	Elongation to failure in the through thickness direction	None

Table D1b - Essential performance requirements for cold formed thin gauge steel

Performance requirement	Specified by	Specific requirements
Minimum yield strength	Smaller of yield strength (R_{eH}), 0.2% proof strength ($R_{p 0.2}$) and stress at 0.5% total elongation ($R_{t 0.5}$)	$R_m / R_{eH} \geq 1.08$ (min) ~ 1.2 (max)
Minimum tensile strength	Tensile strength (R_m)	
Notch toughness	None	None
Ductility	Elongation in a specified gauge length	The total elongation should not be less than: 10% for a 50mm gauge length, or 7% for a 200mm gauge length.
Weldability	None	None
Quality on external/ internal surface	See the relevant standards in Annex A1.8	None
Through thickness property	None	None

D1.2 Quality control of testing

The testing shall be carried out to meet the reference material standards as contained in Annex A1.1 by a HOKLAS accredited laboratory or by other accredited laboratories which have reached mutual recognition agreements/arrangements with HOKLAS.

Table D2 - Minimum material property requirements for various high strength steels

Steel		Source	Yield Strength Y _s N/mm ²	Ultimate Strength U _s N/mm ²	Elongation
Bisplate	60	Australia	500	590-730	20%
	70		600	690-830	20%
	80		690	790-930	18%
HT690	70	Japan	590	690	(Min 20% reqd.)
HT780	80		685	780	(Min 20% reqd.)
RQT	601	UK	620	690-850	(Min 20% reqd.)
RQT	701		690	790-930	(Min 20% reqd.)
HPS	485W	USA	485	-	(Min 20% reqd.)
ASTM A913	70		485	620	16%
ASTM A514	100		690	760 – 895	18%
S500Q		Europe	440 - 500	540 – 590	Refers to Clause 3.1.2
S550Q			490 - 550	590 - 640	
S620Q			560 - 620	650 - 700	
S690Q			630 - 690	710 - 770	

D2 ABSTRACT OF ESSENTIAL REQUIREMENTS FOR BOLTS

Abstract of essential requirements for bolts:

- (a) In a matched assembly of a nut and bolt, the nut must be sufficiently strong enough such that the bolt shank fails in tension prior to the nut or bolt threads stripping.
- (b) When bolts and nuts are galvanized, it is usual that the manufacturer will tap the nut threads oversize in order to fit the galvanized bolt threads. Therefore the nut is required to be stronger than for the case when it is not galvanized in order to comply with (a). Typically the manufacturer should supply a higher grade of nut, e.g. an ISO grade 10 nut for an ISO grade 8.8 bolt.
- (c) Bolts should only be used in the range of strengths given in Table D4 below unless test results demonstrate their acceptability in a particular design application.
- (d) Friction grip bolts may be tightened using the torque control method, part-turn method, or direct tension to BS 7644 or other acceptable standard and the manufacturer's recommendations. Torque spanners and other devices shall be recalibrated in accordance with BS 4604 or other acceptable standard.

Table D3 - Essential performance requirements for bolts

Performance requirement	Specified by
Minimum tensile strength	Tensile testing
Minimum yield strength	Tensile testing
Elongation	Tensile testing
Hardness	Brinell Hardness Testing

Table D4 - Various normally used bolt strengths

Bolt source and grade	Design shear strength p_q (N/mm ²)	Design bearing strength p_b (N/mm ²)	Design yield strength p_y (N/mm ²)	Minimum tensile strength (N/mm ²)
ISO 4.6	160	460	240	400
ISO 6.8	240	900	440	600
ISO 8.8	375	1000	560	800
ISO 10.9	400	1300	700	1000
ISO 12.9	480	1600	840	1200
General grade HSFG ≤ 24	400	1000	590	840
General grade HSFG ≥ 27	350	900	515	735
High strength HSFG	400	1300	700	1000
ASTM A307	165	460	310	425
ASTM A325	330	900	620	855
ASTM A490	415	1300	780	1070
AS/NZS 1111 4.6/S	160	460	280	400
AS/NZS 1252 8.8/S, TB, TF	330	900	580	830
GB50017 Grade 3	130	170	225	325
JGJ 82-91 Grade 8.8	250	750	500	625
JGJ 82-91 Grade 10.9	310	850	630	775
JIS B 1051 Grade 4.6	160	460	240	400
JIS B 1051 Grade 6.8	240	750	480	600

Figures in normal test are from published data and figures in bold are calculated from formulae in Section 9.

Both hardness and toughness of bolts and washers should apply to relevant standard

Precision bolts to BS 3692 or other equivalent

Friction grip bolts to BS 4604: Part 1 or 2 or other equivalent

Bolt tightening to BS4604: Part 1 or other equivalent

Torque control method, part-turn method, or direct tension to BS 7644 or other equivalent and the manufacturer's recommendations

Torque spanners and other devices shall be re-calibrated in accordance with BS 4604 or other equivalent