

CODE OF PRACTICE  
FOR  
FIRE RESISTING CONSTRUCTION

1 9 9 6

BUILDING AUTHORITY

HONG KONG

## FOREWORD

Fire safety in a building is determined by a number of factors one of which is its ability to resist the effects of fire and to minimize the spread of fire and smoke. Requirements for fire resisting construction for buildings are laid down in Part XV of the Building (Construction) Regulations. This Code of Practice provides guidance on compliance with these requirements.

This Code will be reviewed regularly. Suggestions for improving it are welcome.

Building Authority

First issue : November 1989

This revision : January 1996

# C O N T E N T S

<b>Paragraph</b>	<b>Page</b>
<b>Part I - GENERAL PROVISIONS</b>	
1. Use of the Code	1
2. Objectives	1
3. Two Approaches to Fire Safety	1
4. Interpretation	3
<b>Part II - SPECIFIC REQUIREMENTS</b>	
5. Compartmentation	5
6. Fire Resistance Period	6
7. Protection of Adjoining Buildings	9
8. Separation between Uses	9
9. Separation between Occupancies	10
10. Openings through Fire Resisting Walls and Floors	10
11. Vertical Shafts	12
12. Protection against Spread of Fire and Smoke between Floors	14
13. Roofs	15
14. Special Hazards	15
15. Basements	16
16. Bridges and Tunnels	17
17. Doors	18
18. Refuge Floors	19
<b>LIST OF TABLES</b>	
<b>TABLES     A - F</b>	<b>22 - 27</b>
<b>DIAGRAMS  1 - 7</b>	<b>28 - 36</b>

## **Part I - GENERAL PROVISIONS**

### **1. Use of the Code**

- 1.1 Authorised persons, registered structural engineers and any person responsible for the design of buildings may find this Code useful in establishing the requirements of the Building Authority for fire resisting construction.
- 1.2 This Code gives guidance on how the Building Authority's requirements may be complied with.

### **2. Objectives**

- 2.1 The objective of this Code is to announce provisions for the protection of buildings from the effects of fire by inhibiting the spread of fire and ensuring the integrity of the structural elements of buildings.
- 2.2 There are other fire-safety objectives : preventing the outbreak of fire, abating fire hazards, fire suppression, preventing loss of property, providing means of escape and assisting in firefighting and rescue. Provisions for some of these can be found in the Buildings Ordinance and other Codes of Practice issued by the Building Authority.

### **3. Two Approaches to Fire Safety**

- 3.1 Prescriptive Provisions : Compliance with the prescriptive provision in this Code may be regarded as a reliable way to satisfy the Building Authority's requirements. Departure from these provisions will necessitate an alternative approach to be adopted and proved, in individual cases, to the satisfaction of the Building Authority as to compliance with requirements.
- 3.2 Alternative Approach : The Building Authority recognizes that fire safety may be approached in a number of ways the best of which is not necessarily prescriptive. This is particularly pertinent to buildings of special hazards which, because of their size, height, use, design, construction or location, may necessitate special consideration and specific standards. In this Code, the points to note for an alternative approach are set out.

3.3 For the assessment of the need of a building for fire protection, the Building Authority accepts the following as relevant factors :

- the anticipated risk of a fire occurring in the building;
- the anticipated severity of a fire;
- the ability of the structure of the building to resist the effect of fire and to minimize the spread of fire and smoke; and
- the consequential and possible danger to the people in and around the building.

3.4 Where an alternative approach is adopted, the Building Authority will assess its acceptability by reference to a set of criteria. This includes the means of escape, the means of access, the fire service installations, the fire resisting construction, the size, the height, the use, the location and the management of the building. An acceptable alternative approach should take into consideration these criteria and at the same time, applies scientific and engineering principles to the protection of people and property from fire. Such an approach, which is also called "a fire engineering approach", may be the only viable means to a satisfactory standard of fire safety in some large and complex buildings.

3.5 A variety of measures may be taken to achieve fire safety in a building. These measures may provide for or enhance the following :

- the means to prevent fire;
- early fire warning by an automatic detection and warning system;
- the standard of the provision of means of escape;
- the facilities for smoke control;

- the control of the rate of spread of fire;
- the resistance of the effects of a fire;
- the capacity for fire containment;
- fire separation between buildings or parts of buildings;
- the standard of active measures for fire extinguishment or control;
- the facilities to assist in fire-fighting and rescue;
- the effectiveness of property management to minimize the outbreak of fire;
- the availability of personnel trained in fire protection; and
- the availability of any arrangement that could ensure the continued maintenance of fire protection systems.

3.6 Quantitative techniques may be used to evaluate risks and hazards. Some factors listed above may be given numerical values in certain circumstances. When quantitative methods are used, any assumptions made should be substantiated, where possible, by documents from competent authorities.

#### 4. Interpretation

**"balcony approach"** means a balcony which is used as an external approach to a common staircase and which serves two or more occupancies.

**"basement"** of a building means any storey which is below the lower or lowest ground storey and from which all required exit routes are in an upward direction.

**"compartment"** means a portion of a building which is separated from adjoining portions by walls and floors of the required standard of fire resistance assessed as a unit for the purpose of Table 2 herein.

**"compartment volume"** means the volume of the portion of a building contained within the external surfaces of the walls and floors forming a compartment.

**"element of construction"** means :

- (a) any floor, beam, column or hanger;
- (b) any load-bearing wall or load-bearing member other than a member forming the roof or part of the roof;
- (c) any required staircase including the landings and supports thereto.

**"fire resistance period"** or **"FRP"** means the period of time for which any element of construction, wall, fixed light, door, fire shutter or other component of a building is capable of resisting the action of fire when tested in accordance with **BS 476** : Parts 20 to 24 : 1987 or as specified in tables A to F in this Code.

**"ground storey"** of a building means the storey in which is situated an entrance from a street to the building and, where a building fronts or abuts on more than one street and due to a difference in street levels there are two or more entrances from different streets and situated in different storeys, means each such storey.

**"industrial undertaking"** is as defined in the Factories and Industrial Undertakings Ordinance.

**"place of public entertainment"** is as defined in the Places of Public Entertainment Ordinance.

**"refuge floor"** of a building means a protected floor that serves as a place of temporary refuge for the occupants of the building in case of fire.

**"required staircase"** means an access staircase in a firefighting and rescue stairway or a staircase required for means of escape in case of fire.

**Part II - SPECIFIC REQUIREMENTS**

**5. Compartmentation**

- 5.1 Every building should be divided into compartments by walls and floors to inhibit the spread of fire.
- 5.2 Compartment walls, compartment floors, separations and lobbies should be constructed such that all joints are completely filled with non-combustible material to prevent the passage of smoke or flame. No compartment should exceed the volume specified in Table 1 below.

**Table 1. Maximum Compartment Volumes**

Use	Maximum Compartment Volume
Bulk storage and warehouse	7 000 m <sup>3</sup> where the compartment floor is above basement level but not exceeding 30 m in height measured in accordance with Building (Planning) Regulation 23(1)
	3 500 m <sup>3</sup> where the compartment floor is at basement level or exceeding 30 m in height measured in accordance with Building (Planning) Regulation 23(1)
All other uses	28 000 m <sup>3</sup>

Note

Compartment volumes in excess of those given above will be dealt with on individual merits giving full consideration to the performance of equivalent safety standard available in the provision of enhanced means of escape, means of access for firefighting, fire service installations and improved fire resistance of the structure and components.



## 6. Fire Resistance Period

6.1 Every element of construction within each compartment and every compartment wall or compartment floor should have an **FRP** of not less than that specified in Table 2 below.

**Table 2. Fire Resistance Period**

Class	Use	Compartment Volume	Fire Resistance Period
1	Domestic	Not exceeding 28 000 m <sup>3</sup>	1 hour
2	Hotel bedroom		
3	Office		
4	Shop, restaurant and hotel foyer	Not exceeding 7 000 m <sup>3</sup>	1 hour
5	Place of public entertainment		
6	Hospital		
7	Place of assembly	Exceeding 7 000 m <sup>3</sup> but not exceeding 28 000 m <sup>3</sup>	2 hours
8	Carparking		
9	Bulk storage and warehouse	Not exceeding 7 000 m <sup>3</sup>	2 hours
10	Industrial undertaking except bulk storage and warehouse	Not exceeding 28 000 m <sup>3</sup>	2 hours

- Notes :
- (1) Different use classes should be separated in accordance with paragraph 8.
  - (2) Special hazards should be separated in accordance with paragraph 14.
  - (3) For any use not covered by Table 2, the fire resistance period required will be determined by the Building Authority having regard to the fire load, hazard level, fire service installations and other relevant features of the building.

- 6.2 Every element of construction, compartment wall and compartment floor in a basement and the separation between the basement and any adjoining storey should have an **FRP** of not less than 4 hours.
- 6.3 Where a single-storey building does not exceed 7 000 m<sup>3</sup> in volume and 7.5 m in height, any steelwork construction may be unprotected, provided that the building is separated from any adjoining building or the site boundary by a clear unobstructed open space not less than 6 m in width. Where columns and beams are in an external wall, protection against corrosion may be necessary and should be separately considered.
- 6.4 When tested in accordance with BS 476 : Parts 20 to 24 : 1987, the **FRP** required of elements of construction, walls, fixed lights, doors, fire shutters or other components should satisfy one or more of the criteria of stability, integrity or insulation, relating to the various methods of exposure as specified in Table 3.
- 6.5 The construction and materials specified in Tables A to F in this Code are deemed to satisfy the **FRP** as listed therein. If other materials, products or construction are used, they should be tested in accordance with or assessed against BS 476 : Parts 20 to 24 : 1987 and certified as being capable of resisting the action of fire for the specified periods. Such certification should be established by :
- (a) a test report indicating that the material, product or construction is capable of resisting the action of fire for the specified period. The test should be carried out and the test report prepared by a laboratory recognized by the Hong Kong Laboratory Accreditation Scheme or the Building Authority; or
  - (b) an assessment report against BS 476 : Parts 20 to 24 : 1987 that the material, product or construction is capable of resisting the action of fire for the specified period. The assessment should be carried out and the assessment report prepared by -
    - (i) a laboratory recognized by the Hong Kong Laboratory Accreditation Scheme or the Building Authority; or
    - (ii) an establishment or a professional having the appropriate qualifications and experience in fire resisting construction recognized by the Building Authority.

**Table 3**

Elements of construction or other components	Criteria to be satisfied			Method of exposure
	Stability	Integrity	Insulation	
1. Structural frame, beam or column	Y	N	N	exposed faces only
2. Floor including compartment floor	Y	Y	Y	each side separately
3. Roof forming part of an exit route or performing the function of a floor	Y	Y	Y	from underside
4. Loadbearing wall not forming a separating wall or compartment wall	Y	N	N	each side separately
5. External wall	Y*	Y	Y	each side separately
6. Compartment wall	Y*	Y	Y	each side separately
7. Protected shaft, lobby and corridor	Y*	Y	Y	each side separately
8. Fire shutter, fire stop or barrier	N	Y	N	each side separately
9. Smoke outlet shaft	Y	Y	Y	from outside
10. Enclosure around or sealing system for a duct, pipe or wire	N	Y	N	from outside
11. Door (including frame and fixing)	N	Y	N (unless specified)	each side separately (except lift doors - from landing side only)
12. Fixed light (including frame, glazing & fixing)	Y*	Y	Y	each side separately
13. Enclosure around services in staircase/lobby.	N	Y	Y	each side separately

Notes : (1) Y = required  
 N = not applicable  
 Y\* = required for loadbearing elements only

- (2) Lintels, posts or jambs of an opening in a separating or compartment wall should be regarded as an integral part of that wall.
- (3) Any restriction of the cross-section area of the smoke outlet shaft to 75% or less of its original area should be deemed to constitute failure in stability.

## **7. Protection of Adjoining Buildings**

- 7.1 Every building should be suitably enclosed by fire-resisting external walls and roof to ensure protection against spread of fire to adjoining buildings.
- 7.2 Buildings on the same site are regarded as adjoining buildings if they are less than 1.8 m apart. Any part of any such building within 1.8 m of any such adjoining building should be enclosed by imperforate external walls and roof having the same **FRP** as that of the internal elements of construction. Openings protected by fixed lights having an **FRP** of not less than 1/2 hour, 1 hour in the case of a required staircase or its lobby, may however be made in such external walls and roof provided that they are not less than 900 mm from any part of any such adjoining building having an **FRP** of less than that of the internal elements of construction.
- 7.3 Notwithstanding paragraph 7.2, unprotected openings may be made in any such external walls and roof of any building provided they are not less than 1.8 m from any unprotected opening in any such adjoining building.
- 7.4 Any part of any building within a distance of not more than 900 mm of a common boundary with an adjoining site should be enclosed by imperforate external walls and roof having the same **FRP** as that of the internal elements of the construction. Openings protected by fixed lights having an **FRP** of not less than 1/2 hour, 1 hour in the case of a required staircase or its lobby, may however be made in such external walls and roof provided they are not less than 450 mm from such boundary.
- 7.5 See Diagram 1 for illustration of the requirements of this paragraph.

## **8. Separation between Uses**

- 8.1 Where parts of any building are for different uses as classified in Table 2, separation should be made between them by compartment walls and floors having the longer of the **FRPs** specified therein in respect of such uses but in no case less than 2 hours.
- 8.2 Ancillary small offices, caretakers' quarters and small storage areas or loading and unloading areas in an industrial building do not require such separation.

## **9. Separation between Occupancies**

- 9.1 Where a building is used for different type of occupancy, they should be separated by walls and floors having an **FRP** of not less than that required for the elements of construction of the compartment in which they are situated, subject to a maximum of 2 hours.
- 9.2 Occupancies for use for retail or as offices do not require such separation, provided that they are under a common and effective management and a common fire alarm system, actuated by a sprinkler alarm or by break glass points, is installed. The Building Authority has to be satisfied that the different occupancies are under a common management and that such management is effective.
- 9.3 Except for shopping arcades, every internal corridor serving rooms or flats in different occupancies should be separated from such occupancies by walls having an **FRP** of not less than 1 hour. The doorway giving access from the rooms or flats to the internal corridor should have a door with an **FRP** of not less than 1/2 hour. Fixed lights having an **FRP** of not less than 1/2 hour may be installed in such separating walls at a height of not less than 1.8 m.
- 9.4 Except where the means of escape is in two directions, balcony approach serving rooms or flats in different occupancies should be separated from such occupancies by walls having an **FRP** of not less than 1 hour. The doorway giving access from the rooms or flats to the balcony approach should be provided with a door having an **FRP** of not less than 1/2 hour. Fixed lights having an **FRP** of not less than 1/2 hour may be installed in such separating walls at a height of not less than 1.8 m.

## **10. Openings through Fire Resisting Walls and Floors**

- 10.1 Openings may be made in compartment walls for communication, but not combination, of adjoining compartments, provided that any such opening is protected by a door or a fire shutter with the same **FRP** as the wall with regard to the criteria of integrity and insulation. The criterion of insulation is not applicable to such doors and fire shutters when the total width of the openings to be formed is not more than 25% of the length of the compartment wall.

- 10.2 Escalators or staircases, other than required staircases, which perforate floors between compartments may be unenclosed in one compartment provided that such escalators or staircases are enclosed in the adjoining compartment by walls having an **FRP** of not less than the longer period required for the elements of construction of the compartments so served. Every opening in such enclosing walls should be provided with a door or fire shutter having an **FRP** of not less than half that of the enclosing wall in which it is situated.
- 10.3 Where a ramp crosses a division between two compartments, the opening in the compartment wall should be provided with a fire shutter having an **FRP** of not less than the longer period required for the elements of construction of the two compartments so served. Where installation of shutters is not practical, the Building Authority may consider accepting drenchers in lieu of shutters. The drencher system shall be designed and installed to the satisfaction of the Director of Fire Services.
- 10.4 Subject to paragraph 11, openings may be made through compartment floors for vertical shafts.
- 10.5 Every opening for the passage of air-conditioning ducts, ventilation ducts, electrical trunking, conduits, pipes and wires through a compartment wall or floor, and every hole in such a wall or floor left after construction should be protected with fire dampers or other suitable form of fire stop to maintain the required **FRP** of that wall or floor. Where the ducts, pipes, wires and any insulation passing through such a wall or floor is of combustible material, such material should be contained within an enclosure having an **FRP** of not less than that of the wall or floor. Any access openings provided to the enclosure should be provided with doors having an **FRP** of not less than 1/2 that of the enclosure.
- 10.6 Where an opening is formed for ducts, pipes and wires of combustible material passing through walls or floors, not being compartment walls or compartment floors, which are required to have an **FRP**, and such opening is not contained within an enclosure as stipulated in paragraph 10.5, the opening in the wall or floor should be protected by a sealing system around the duct, pipe or wire having an **FRP** of not less than that of the wall or floor and complying with the following criteria :
- (a) the sealing system should be tested or assessed in accordance with the general principles for fire resistance given in BS476 : Part 20: 1987;
  - (b) the performance of the sealing system should not be affected by moisture or dampness;

(c) the life of the sealing system should not be shorter than that of the duct, pipe or wire; and

(d) the sealing system should be firmly fixed.

10.7 Fire shutters should be constructed, installed and assembled to the satisfaction of the Building Authority. Fire dampers and the operation of fire shutters and fire dampers should be designed, installed, tested and maintained to the satisfaction of the Director of Fire Services.

## 11. Vertical Shafts

11.1 All liftwells, except for openings for doors and ventilation or openings between the liftwell and the machine or pulley room, should be separated from the rest of the building by walls and floors having an **FRP** of not less than 2 hours. Holes in a liftwell wall around frames or reveals of lift landing doors, floor indicator panels and lift call buttons should be properly filled and sealed to maintain the **FRP** of the wall.

11.2 A door provided at a lift landing to give access to the car of a lift and any other door to a liftwell wall should have an **FRP** of not less than 1 hour with regard to integrity and, where so required as shown in **Diagram 2**, also with regard to insulation.

11.3 All required staircases and any lobbies intercepting these staircases from the accommodation of a storey should :

(a) be separated from the rest of the building by walls having an **FRP** of not less than that required for the elements of construction of the compartment to which they connect;

(b) be imperforate, except for any doorway giving access to the building which should be provided with a door having an **FRP** with regard to the criterion of integrity of not less than 1/2 that of the wall in which the doorway is situated or 1 hour, whichever is the less, and with regard to insulation of not less than 1/2 hour. No such door should be required between a balcony approach and a required staircase leading therefrom if such staircase is open to the external air for at least 50% of its perimeter, measured on plan, from the top of the balustrade or parapet to the underside of the flight of the staircase immediately above; and

- (c) not accommodate any other than emergency services such as fire hydrants, sprinkler systems, emergency lights and exit signs unless such services are enclosed by enclosures having an **FRP** of not less than that of the walls separating the staircase from the rest of the building. Any access openings in such enclosures should be provided with a door having an **FRP**, with regard to integrity, of not less than half that of the wall or 1 hour, whichever is the less, and, with regard to insulation, of not less than 1/2 hour.
- 11.4 Each element of construction of a required staircase including the landings and supports enclosed within walls having the required **FRP** need not have an **FRP** but must be non-combustible.
- 11.5 When the ground storey of a single-staircase building is used for any occupancy other than domestic or office, the staircase from ground to first floor level should be separated from the rest of the building by a wall having the longer of the **FRPs** specified therein in respect of such uses and the wall enclosing the staircase should, at the main entrance, be returned for a distance of not less than 450 mm along the frontage of the ground storey occupancy.
- 11.6 Subject to paragraphs 7, 11.7 and 11.8, an external wall of a required staircase and of any lobby intercepting between the staircase and the accommodation of a storey may be unprotected and openings may be made in the external wall.
- 11.7 Where any part of the external wall coming under para 11.6 opposes, either directly or indirectly, and is within 6 m of -
- (i) the opposite side of a street;
  - (ii) a common boundary with an adjoining site;
  - (iii) any other external wall having an **FRP** of less than that required for the wall separating the staircase or lobby concerned from the rest of the building, or other opening not protected by fixed light with an **FRP** of not less than half of that required for the wall of the staircase or lobby concerned of the same building;  
or
  - (iv) any other building on the same site.



that part of the external wall shall have an **FRP** of not less than that required for the wall separating such staircase or lobby from the remainder of the building. It should also be imperforate, unless protected by fixed light which should not occupy more than 25% of the area of the external wall of the storey in which it is located with an **FRP** as described in (iii) above or, in the case of the discharge point at ground level or roof level, a door with an **FRP** of not less than half that required for the wall. See diagram 3 for illustration.

- 11.8 Where the external wall coming under para 11.6 continues in the same plane with other external walls of the same building and both such walls have an **FRP** of less than that required for the wall separating the staircase or lobby concerned from the rest of the building, the remaining fire resisting walls of the staircase or lobby should, at the junction with such external wall, be extended for a distance of not less than 450 mm at any angle, except that at the ground level discharge the extension should not project beyond the external wall. See Diagram 4 for illustration.

## **12. Protection against Spread of Fire and Smoke between Floors**

- 12.1 At any internal unprotected opening in floors within a compartment, such as those for escalators, circulation staircases or walkways in an atrium, a barrier of not less than 450 mm measured vertically downwards from the underside of the floor should surround the opening. The barrier should be constructed to have an **FRP** of not less than 1 hour. Floor openings tend to create vertical or horizontal drafts which permit the spread of fire and smoke. The barrier around such openings should serve to stop heated air and smoke properly and permit the control of fire at any point by local sprinklers. If false ceilings are hung in the vicinity of the opening, the barrier should extend not less than 450 mm below the false ceiling. Having regard to the difficulties in some situations in providing barriers due to low headroom or false ceilings, alternative installations may be provided, such as smoke reservoirs, perforate or open ceilings, dynamic smoke extraction system and smoke detector operated devices. Consideration may be given by Building Authority to such installations on the merits of each case and approval will depend on the demonstration of their effectiveness and proper control and management after completion. See Diagrams 5 and 6 for illustration.

- 12.2 A curtain wall or other similar construction, which protects the building against the elements and which extends beyond one storey in height, should be constructed entirely of non-combustible materials. Any void formed between the curtain wall and the perimeter of the building onto which the curtain wall is fixed should be solidly infilled at each floor level by non-combustible materials having an **FRP** of not less than that required for the floor.
- 12.3 Subject to paragraph 7, the external wall of a building at any floor should be separated from the external wall at the floor next below by a spandrel which :
- (a) is not less than 900 mm in height; and
  - (b) is of non-combustible materials having an **FRP** of not less than that of the intervening floor. See Diagram 7 for illustration.

### 13. Roofs

- 13.1 All roofs, together with the members forming the roof structure, should be constructed of non-combustible materials.
- 13.2 The roof of every single-staircase building in which the level of the highest floor is more than 13 m above ground level should have an **FRP** of not less than 1 hour. The main roof or any other roof of any building, which is used or intended to be used as a refuge floor or part of a refuge floor, should have an **FRP** of not less than 2 hours.

### 14. Special Hazards

- 14.1 Areas for electrical or hazardous installations or storing dangerous goods should be separated from the rest of the building by enclosures of non-combustible construction having an **FRP** of not less than 2 hours or 4 hours where adjoining required staircases. Any permitted openings to such enclosures should be provided with a door having an **FRP** of not less than 1 hour.

14.2 Other areas of high fire risk directly associated with a normal occupancy in a building should be separated from the rest of the building by enclosures of non-combustible construction having an **FRP** of not less than 2 hours.

14.3 In any domestic premises provided with a single exit door, a kitchen adjacent to such door should be separated from the rest of the premises by walls having an **FRP** of not less than 1 hour and the entrance to the kitchen should be provided with a door having an **FRP** of not less than 1/2 hour.

## 15. Basements

15.1 Where a basement has the same use as the ground storey and any upper storeys, it may be united thereto provided that every element of construction, compartment wall and compartment floor in such storeys and the construction separating the uppermost of such storeys from the storey above have the same **FRP** as that of the basement.

15.2 Every basement should be provided with smoke outlets, which should :

- (a) be not more than 30 m apart and situated along the street frontages or adjacent to external walls;
- (b) be sited at a high level, be evenly distributed around the perimeter of the building and be so arranged as to create a through draught;
- (c) be provided to every compartment in the basement;
- (d) have an area in aggregate of not less than 0.5 per cent of the floor area they serve or, in areas used for bulk storage or warehouse, not less than 2.5 per cent of the floor area they serve;
- (e) be not less than 1 m in its least dimension;
- (f) be situated as far away as possible from the points of discharge of all required staircases and be suitably indicated on the external face of the building;
- (g) be covered by stall-boards or pavement lights that can be easily broken by fire-fighters in an emergency; and

- (h) where terminating in the open air in a position inaccessible to a fire-fighter, be maintained unobstructed or covered only with a grill or louvres constructed of metal other than aluminum.
- 15.3 Where a dynamic smoke extraction system is provided in a basement which is subject to the satisfaction of the Director of Fire Services, smoke outlets should be provided as follows :
- (a) have at least one smoke outlet for every 3500 m<sup>3</sup> of compartment volume, but in no case less than 1 outlet per floor;
  - (b) be readily accessible to fire-fighting personnel in an emergency; and
  - (c) comply with the requirements of paragraph 15.2, except (d) and (h) thereof unless incompatible with the requirements in (a) and (b);
- 15.4 Where a smoke outlet shaft serving a basement extends into or through another storey, it should have an **FRP** or be protected with an enclosure having an **FRP** not less than that required for the element of construction of the storey served or through which it passes, whichever is the longer. Where a smoke outlet shaft serving a basement adjoins another smoke outlet shaft, they should be similarly separated from each other. An unenclosed smoke outlet shaft should be capable of resisting accidental mechanical damage and should satisfy the hard body impact test in accordance with BS 5669.

## 16. Bridges and Tunnels

- 16.1 A bridge uniting two or more buildings should be provided at each end with a fire shutter having an **FRP** of not less than 2 hours and a by-pass lobby the walls of which should have an **FRP** of not less than 2 hours and the doors should have an **FRP** of not less than 1 hour. Where two fire shutters each having an **FRP** of not less than 2 hours are installed at either end of the bridge, a by-pass lobby will not be required unless the bridge is longer than 18 m. In respect of the latter situation, the bridge will be regarded as an integral part of the building not installed with the fire shutters. The bridge should be of non-combustible construction having an **FRP** of not less than that of the lower of the buildings. No opening should be formed in the walls of either building within a distance of 900 mm from the junction of the bridge with either building and the walls of the buildings within this distance should be of non-combustible construction having an **FRP** of not less than 2 hours.

16.2 Paragraph 16.1 does not apply to a bridge that :

(a) is constructed wholly of non-combustible materials; and

(b) is provided at the sides with only barriers or parapets not higher than 1.2 m.

16.3 Tunnels uniting two or more buildings should be provided at each end with a fire shutter having an **FRP** of not less than 4 hours and a by-pass lobby the walls of which should have an **FRP** of not less than 4 hours and the doors should have an **FRP** of not less than 2 hours. Where two fire shutters each having an **FRP** of not less than 4 hours are installed at either end of the tunnel, a by-pass lobby will not be required unless the tunnel is longer than 18 m. In the latter situation, the tunnel will be regarded as an integral part of the building not installed with the fire shutters. The tunnel should be of non-combustible construction having an **FRP** of not less than 4 hours.

## 17. Doors

17.1 All doors required to have an **FRP** should be self-closing. Doors to required staircases and the lobbies intercepting them from the accommodation of a storey must remain closed. Other doors are allowed to be open provided that the hold-open device can be released manually and upon actuation of a smoke detection system or the operation of a fire alarm system, designed and installed to the satisfaction of the Director of Fire Services for the door to become self-closing again.

17.2 Except for doors with hold - open devices complying with paragraph 17.1, all doors required to have an **FRP** should be provided with a notice on both sides stating in English letters and Chinese characters, not less than 10 mm high, as follows :



- 17.3 All such doors should be closely fitted around their edges to impede the passage of smoke or flame. The bottom gap between such doors and the floor should not exceed 4 mm.
- 17.4 Such doors should comply with the following requirements :
- (a) All doors including frames should be tested or assessed in accordance with BS 476 : Part 22 : 1987 and certified in accordance with paragraph 6.5 as being capable of resisting the action of fire, in terms of integrity and insulation or in terms of integrity only, as the case may be, for the specified period. The method of exposure when the door is tested should be from each side of the door separately, except in the case of lift doors which should be tested from the landing side only;
  - (b) Unless shown to be satisfactory when tested as part of a door assembly, any hinge on which such doors are hung should be made entirely of materials having a melting point of at least 800°C; and
  - (c) The maximum area of uninsulated glazing used in doors which are not required to be insulated should not exceed 25% of the area of the door leaf.
- 17.5 The aggregate area of the openings for such doors should not exceed 1/2 of the overall area of the wall in which the doors are situated. Otherwise, the doors should have an **FRP** of not less than that of the wall.

## 18. Refuge Floors

- 18.1 The area for refuge on every refuge floor in a building should be separated from the rest of the building, including vertical shafts or ducts passing through such floor, by walls and floors having an **FRP** of not less than 2 hours. Vertical shafts or ducts passing through a refuge floor should not open directly onto that floor.
- 18.2 Where the side of a refuge floor is required to be open, the open side should not directly or diagonally be within a distance of less than 6 m from :
- (a) the opposite side of a street;
  - (b) a common boundary with an adjoining site;

- (c) any other external wall having an **FRP** of less than 2 hours or other opening not protected by fixed light with an **FRP** of not less than 1 hour of the same building;  
or
- (d) any other building on the same site.

## **LIST OF TABLES**

1. The Tables which follow set out the minimum standard of construction and building materials capable of resisting the action of fire for the specified periods. If other materials, products or construction are used, they should be tested or assessed and certified in accordance with paragraph 6.5.

2. In this List :

"**gypsum plaster**" means gypsum building plaster complying with BS 1191;

"**gypsum plaster board**" means gypsum plaster board complying with BS 1230.

3. The List contains :

Table A on Walls Constructed Wholly of Non-combustible Materials

Table B on Walls not Constructed Wholly of Non-combustible Materials

Table C on Floors and Landings

Table D on Steel Columns and Beams

Table E on Reinforced Concrete Columns and Beams

Table F on Stairs

## **DIAGRAMS**

The diagrams included in this Code are :

Diagram 1 : Protection of Adjoining Buildings

Diagram 2 : Examples of Structural Arrangements in relation to Fire Resistance of Lift Doors

Diagram 3 : Openings at the External Walls of Staircases/Lobbies

Diagram 4 : Separation between Staircases Lobbies from the General Accommodation

Diagram 5 : Vertical Barrier at Escalator

Diagram 6 : Vertical Barrier at Atrium

Diagram 7 : Protection against Spread of Fire by Spandrels



**TABLE A**

**WALLS CONSTRUCTED WHOLLY OF NON-COMBUSTIBLE MATERIALS**

Construction and Materials	Minimum thickness in mm (excluding plaster) for period of		
	4 hrs.	2 hrs.	1 hr.
<b>SOLID CONSTRUCTION</b>			
Solid bricks of clay, concrete or sand lime without plaster	225	225*	100
Reinforced concrete -			
(a) containing not less than 1 per cent of vertical reinforcement	180	100	75
Concrete cover to main reinforcement	25	25	15
(b) containing less than 1 per cent of vertical reinforcement	240	160	120
Concrete cover to main reinforcement	25	25	25
<b>HOLLOW BLOCK CONSTRUCTION</b>			
Clay blocks (outer web not less than 13 mm thick) of 2 cells not less than 50 per cent solid finished with 13 mm gypsum plaster on each side		100	100
Concrete blocks of one cell in wall thickness not less than 50 per cent solid finished with 13 mm gypsum plaster on each side			190

\* Where finished with 13 mm gypsum plaster on each side, the thickness may be reduced to 100 mm.

**TABLE B**  
**WALLS NOT CONSTRUCTED WHOLLY**  
**OF NON-COMBUSTIBLE MATERIALS**

Construction and Materials	Minimum thickness of finish in mm on each face for period of	
	2 hrs.	1 hr.
<b>SOLID CONSTRUCTION</b>		
Wood wool slabs - complying with BS 1105 -		
(a) 50 mm minimum thickness with gypsum plaster finish		13
(b) 75 mm minimum thickness with gypsum plaster finish	13	6
Gypsum plaster board in cores not less than 19 mm thick in section not more than 1.2 m wide supported top, bottom and sides in steel channels or a timber framework, with gypsum plaster finish		10
<b>HOLLOW CONSTRUCTION</b>		
Steel or timber framing with facings on each side of -		
(a) Portland cement plaster, Portland cement-lime plaster or gypsum plaster on metal lathing		19
(b) 2 layers of 10 mm thick gypsum plaster board with gypsum plaster finish		Nil
(c) 13 mm thick gypsum plaster board with gypsum plaster finish		6
(d) 19 mm thick gypsum plaster board with gypsum plaster finish		Nil

**TABLE C**  
**FLOORS AND LANDINGS**

Construction and Materials	Minimum thickness in mm for period of		
	4 hrs.	2 hrs.	1 hr.
<b>SOLID REINFORCED CONCRETE CONSTRUCTION</b>			
Thickness of concrete	170	125	100
Concrete cover to all reinforcement -			
simply supported	55*	35	20
continuous	45*	25	20
<b>SOLID PRESTRESSED CONCRETE CONSTRUCTION</b>			
Depth including screed	170	125	100
Concrete cover to all steel -			
simply supported	65*	40	25
continuous	55*	35	20

\* Reinforcement consisting of expanded metal lath or a wire fabric not lighter than 0.5 kg/m<sup>2</sup> with 2 mm diameter wire at not more than 100 mm centres or a continuous arrangement of links at not more than 200 mm centres should be incorporated in the concrete cover at a distance not exceeding 20 mm from the face.

**TABLE D**  
**STEEL COLUMNS AND BEAMS**

Construction and Materials	Minimum thickness of protection in mm for period of		
	4 hrs.	2 hrs.	1 hr.
<b>SOLID PROTECTION</b>			
Columns and hangers (mass per metre not less than 45 kg)			
(a) Concrete not inferior to Grade 20 and reinforced in accordance with the Code of Practice for the Structural Use of Steel	75	50	50
(b) Solid bricks of clay, concrete or sand lime	75	50	50
Beams (mass per metre not less than 30 kg)			
Concrete not inferior to Grade 20 and reinforced in accordance with the Code of Practice for the Structural Use of Steel	75	50	50
<b>HOLLOW PROTECTION</b>			
Columns and hangers (mass per metre not less than 45 kg)			
(a) Solid bricks of clay, concrete or sand lime reinforced in every horizontal joint with steel binding wire not less than 2.5 mm in thickness or steel mesh weighing not less than 0.5 kg/m <sup>2</sup> .	115	50	50
(b) Portland cement plaster, Portland cement-lime plaster or gypsum plaster on metal lathing.			19
(c) Gypsum plaster on 10 mm gypsum plaster board with 1.6 mm diameter wire binding at 100 mm pitch			13
(d) Gypsum plaster on 19 mm gypsum plaster board with 1.6 mm diameter wire binding at 100 mm pitch		13	7
Beams (mass per metre not less than 30 kg)			
(a) Portland cement plaster or Portland cement-lime plaster on metal lathing			19
(b) Gypsum plaster on metal lathing		22	16
(c) Gypsum plaster on 10 mm gypsum plaster board with 1.6 mm diameter wire binding at 100 mm pitch			13
(d) Gypsum plaster on 19 mm gypsum plaster board with 1.6 mm diameter wire binding at 100 mm pitch		13	7

In this Table -

"hollow protection" means there is a void between the protective material and the web of the steel section, such hollow protection to columns should be effectively sealed at each floor level.

"solid protection" means casing which is bedded close to the steel without any intervening cavities and with all joints in that casing made full and solid.

**TABLE E**  
**REINFORCED CONCRETE COLUMNS AND BEAMS**

Construction and Materials	Minimum overall size of column in mm for period of		
	4 hrs.	2 hrs.	1 hr.
<b>REINFORCED CONCRETE COLUMNS AND HANGERS</b>			
(a) Fully exposed columns and hangers	450	300	200
Concrete cover to main reinforcement	35	35	25
(b) 50 per cent exposed of columns and hangers	350	200	160
Concrete cover to main reinforcement	35	25	25
(c) One face exposed of columns and hangers	240	160	120
Concrete cover to main reinforcement	25	25	25
<b>REINFORCED CONCRETE BEAMS</b>			
Width of beam	280	200	200
Concrete cover to main reinforcement -			
simply supported	80*	50*	30
continuous	60*	40	30
<b>PRESTRESSED CONCRETE BEAMS</b>			
Width of beam	280	200	200
Concrete cover to tendons -			
simply supported	90*	70*	30

\* Reinforcement consisting of expanded metal lath or a wire fabric not lighter than 0.5 kg/m<sup>2</sup> with 2 mm diameter wire at not more than 100 mm centres or a continuous arrangement of links at not more than 200 mm centres should be incorporated in the concrete cover at a distance not exceeding 20 mm from the face.

**TABLE F**  
**STAIRS**

Construction and Materials	Minimum thickness in mm for period of		
	4 hrs.	2 hrs.	1 hr.
Reinforced concrete construction -			
Thickness at waist of slab	170	125	95
Concrete cover to all reinforcement	55*	35	20

\* Reinforcement consisting of expanded metal lath or a wire fabric not lighter than 0.5 kg/m<sup>2</sup> with 2 mm diameter wire at not more than 100 mm centres or a continuous arrangement of links at not more than 200 mm centres should be incorporated in the concrete cover at a distance not exceeding 20 mm from the face.

Diagram 1 : Protection of Adjoining Buildings (see para.7)

Example (a) : Building with adjoining site

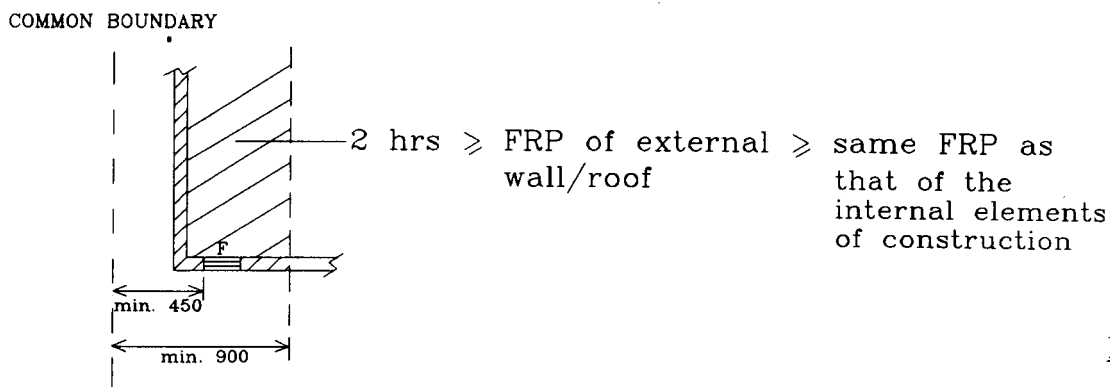

Example (b) : Buildings within the same site

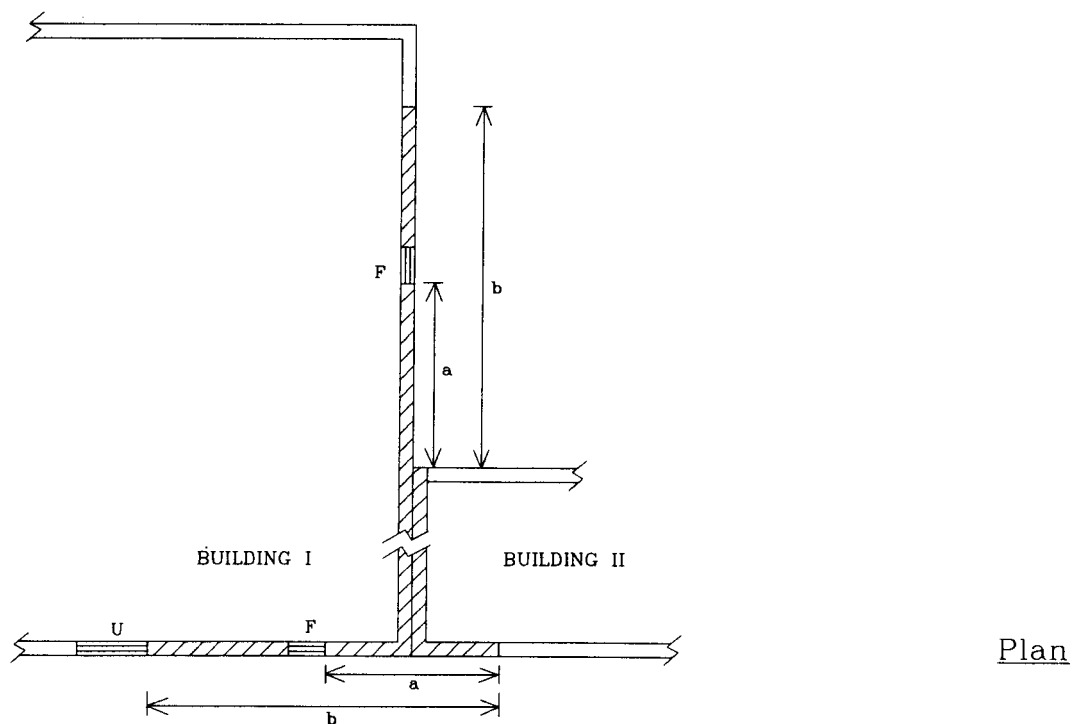

- 2 hrs  $\geq$  FRP of external  $\geq$  same FRP as that of the wall/roof internal elements of construction
- F fixed lights complying with para. 7.2/7.4
- U unprotected openings
- a min. 900mm
- b min. 1800mm

Example (c) : The minimum distance between unprotected openings of two buildings

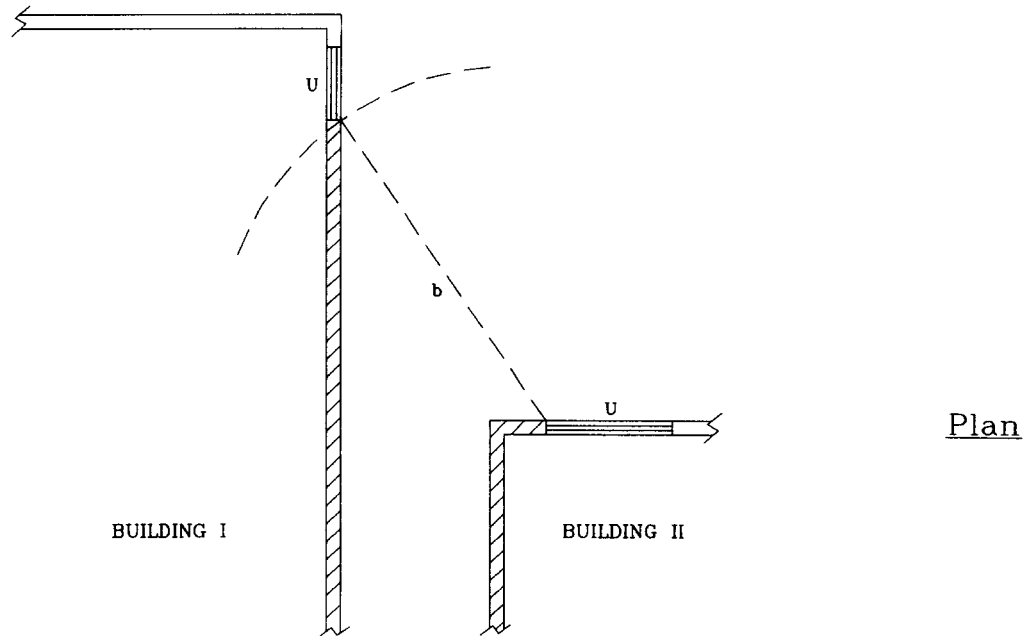

Example (d) : The minimum distance between unprotected and protected openings of two buildings

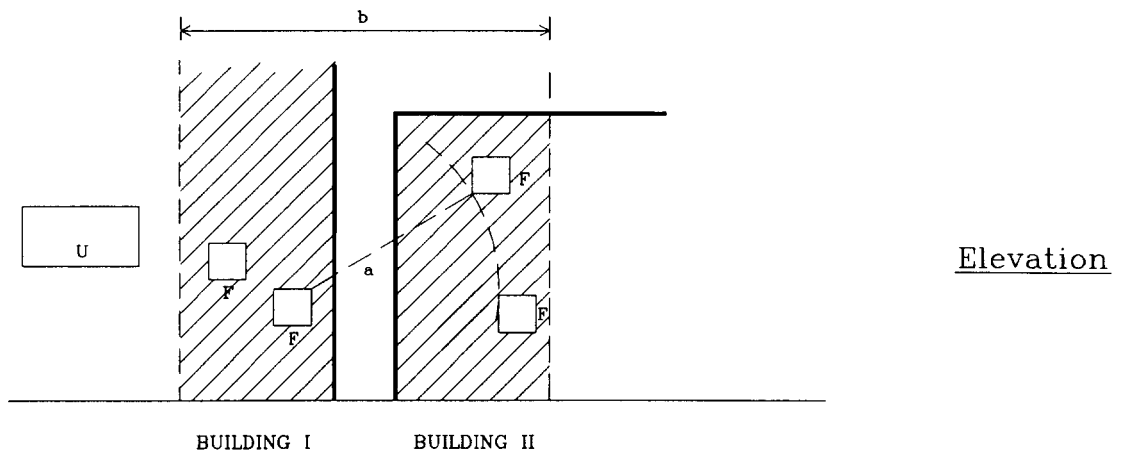

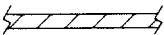
- |   |   |
|---|---|
|  | 2 hrs $\geq$ FRP of external $\geq$ same FRP as that of the wall/roof internal elements of construction |
| F   | fixed lights complying with para. 7.2/7.4   |
| U   | unprotected openings  |
| a   | min. 900mm  |
| b   | min. 1800mm   |



Example (e) : The three-dimension diagram illustrates the minimum distance between unprotected and protected openings of two buildings

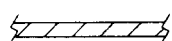
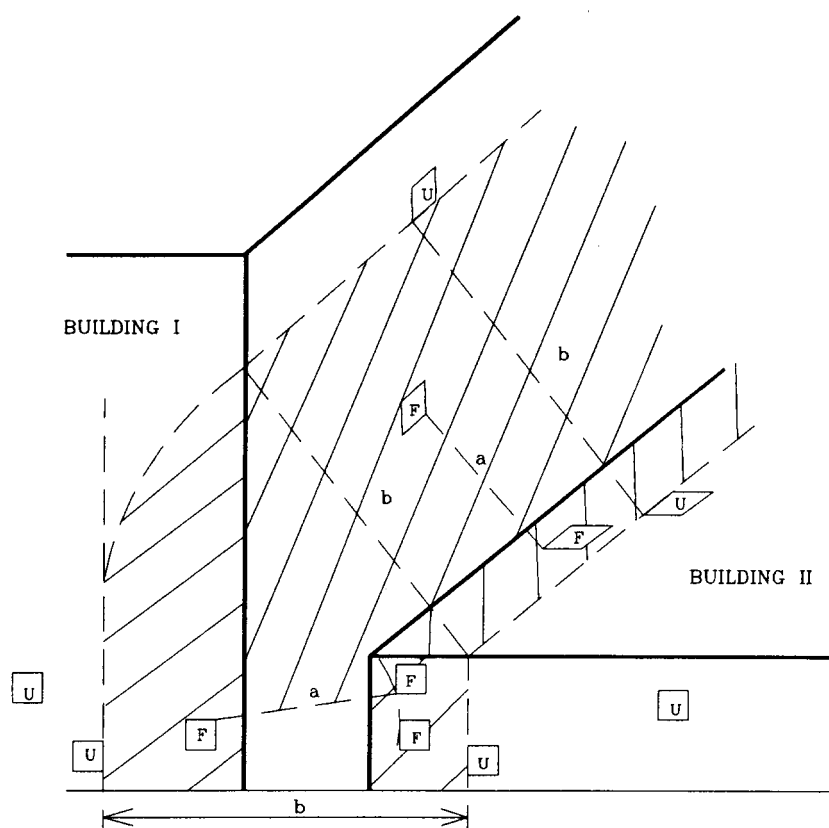

2 hrs  $\geq$  FRP of external  $\geq$  same FRP as that of the  
wall/roof internal elements of construction

F fixed lights complying with para. 7.2/7.4

U unprotected openings

a min. 900mm

b min. 1800mm

**Diagram 2 : Examples of Structural Arrangements in relation to Fire Resistance of Lift Doors.**  
[see para. 11.2]

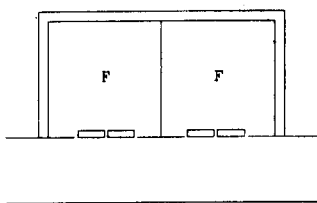

1. The lift landings are not isolated

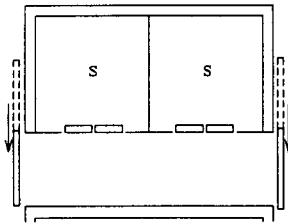

2. The lift landings are isolated

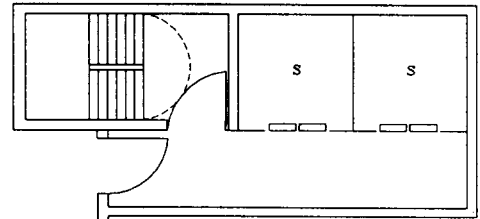

3. The lift landings and the stairwell are isolated

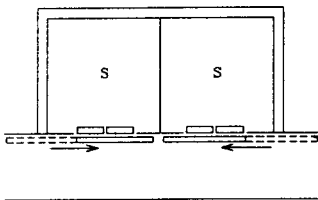

4. The lift doors are backed up by separate fire resisting doors

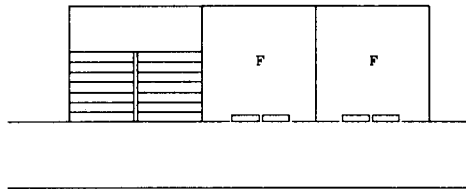

5. The lift landings common to stair landings are not isolated

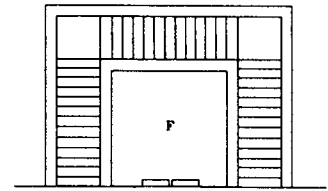

6. Lift completely surrounded by a stairwell

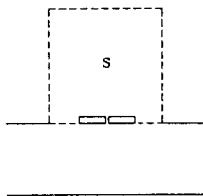

7. Lift adjoining a building

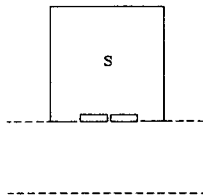

8. Lift installed in a ball or open space within a building

- Notes :
- (1) S=lift doors required to satisfy criteria for integrity only,  
F=lift doors required to satisfy criteria for integrity and insulation.
  - (2) The walls of the well and the doors (apart from the lift) are shown with a double line when they are fire resistant, without prejudging their degree of resistance.
  - (3) In the case of a structural arrangement not shown in this diagram, the choice of the type of door should be made by comparison.

Diagram 3 : Openings at the External Walls of Staircases/Lobbies.  
(see para. 11.7)

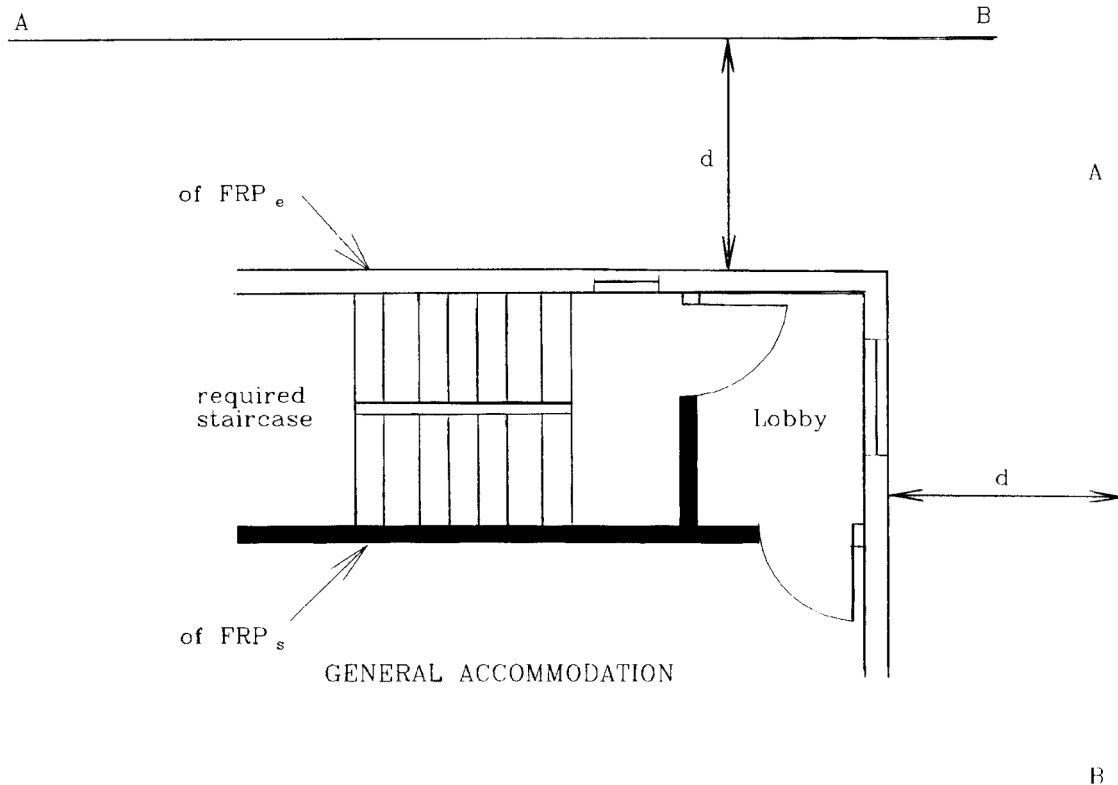

- AB :
- i) opposite side of a street,
  - ii) common boundary with an adjoining site,
  - iii) any other external wall of  $FRP < FRP_e$  or unprotected opening of the same building,
  - iv) any other building on the same site.

External wall may be unprotected if  $d > 6m$

External wall with  $FRP_e \geq FRP_s$  if  $d \leq 6m$

Openings : i)  $d \leq 6m$  ó fixed light with  $FRP \geq 1/2 FRP_e$  ;

ó door with  $FRP \geq 1/2 FRP_e$  for :

\*discharge point at G/F

\*roof level

ii)  $d > 6m$  ó unprotected

Diagram 4 : Separation between Staircases/Lobbies from the General Accommodation  
(see para. 11.8)

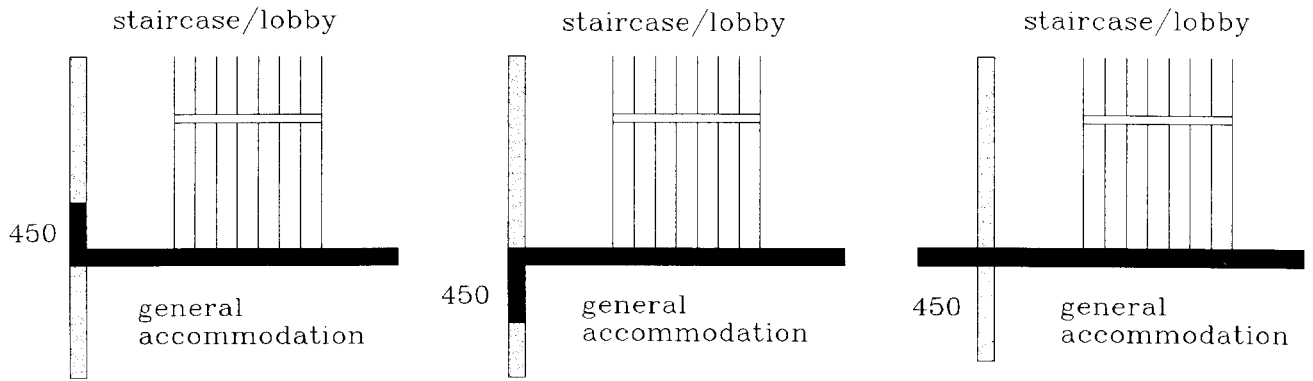

External wall with  $FRP_e$



Wall separating the staircase or lobby from the rest of the building with  $FRP_s$

where  $FRP_s > FRP_e$

Diagram 5 : Vertical Barrier at Escalator (see para. 12.1)

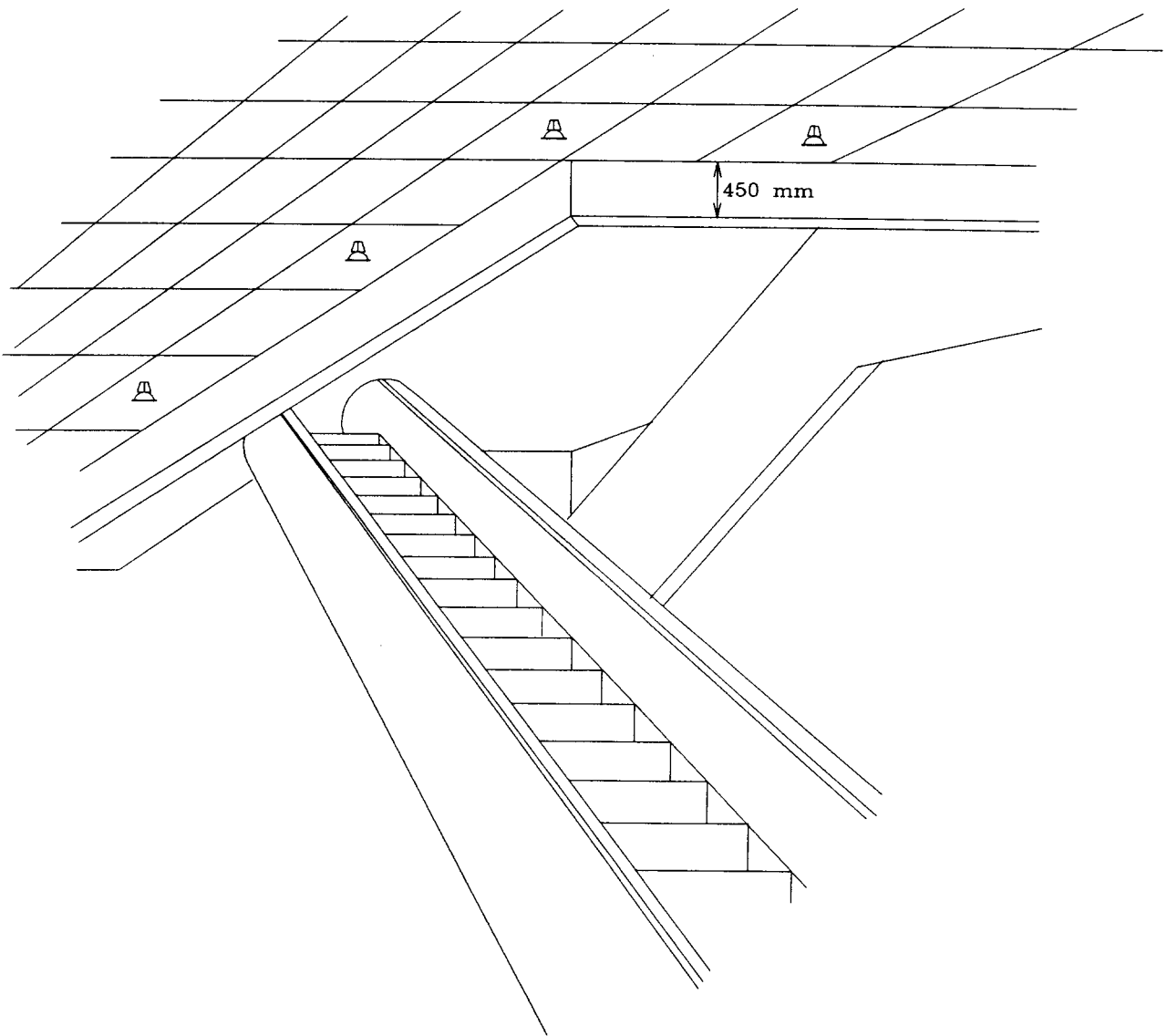

Diagram 6 : Vertical Barrier at Atrium (see para. 12.1)

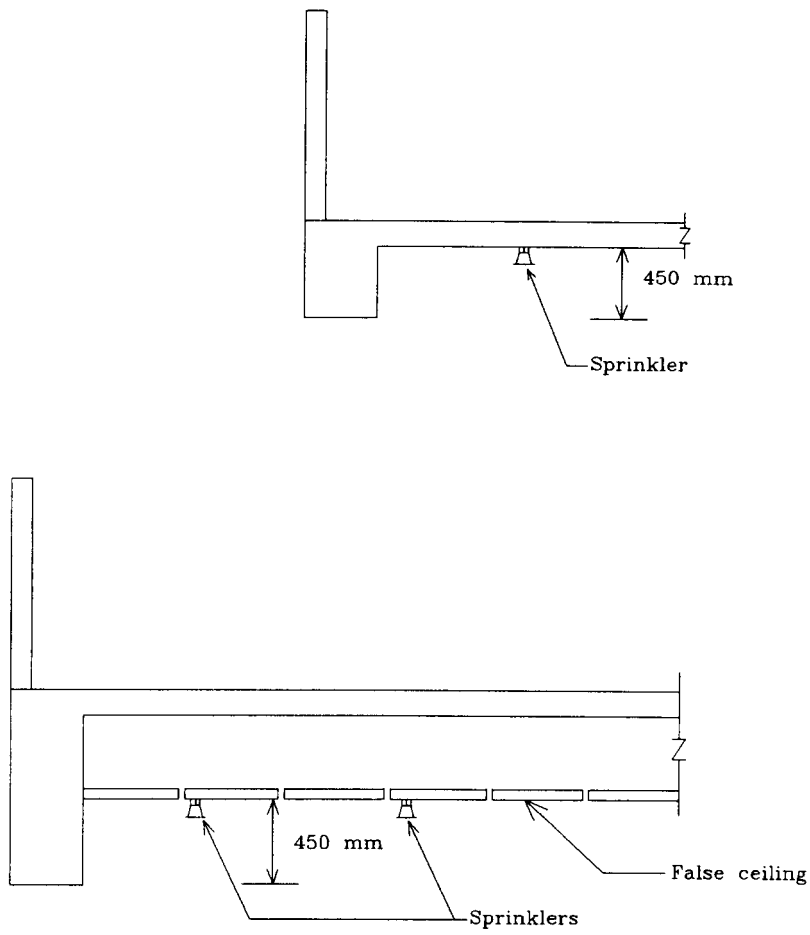
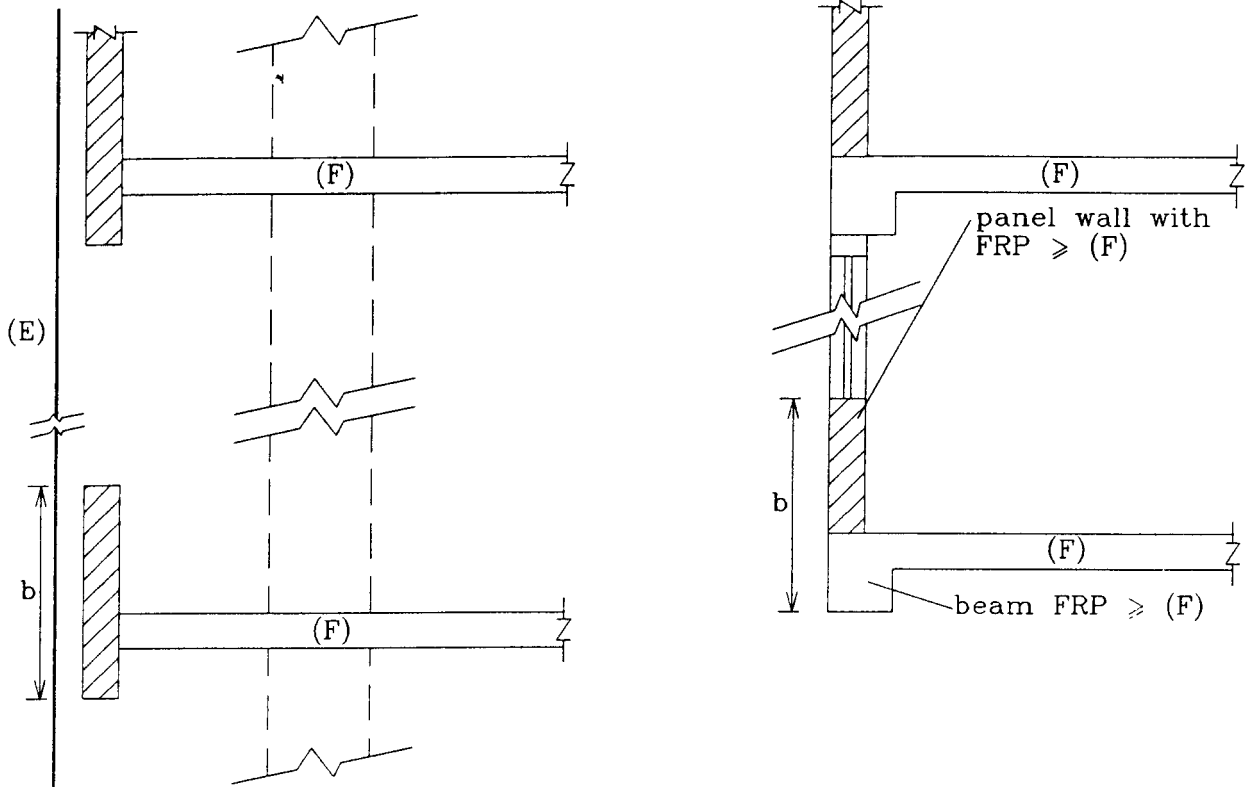
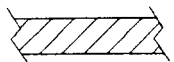

Diagram 7 : Protection against Spread of Fire by Spandrels  
(see para. 12.3)



(F) intervening floor



spandrel of non-combustible materials having FRP  $\geq$  that of (F)

$b \geq 900$  mm

(E) external wall (e.g. curtain wall) with no FRP or FRP  $<$  that of (F)